

8

Line 3: (44) 23 74 37 69
Fax: (44) 23 74 37 69
M1 name: Bala raman
Mobile 1: (0) 94 443 86 661
Email 1: dhayalvr@vsnl.com

- Projection Design for Projection Design products

First Name: Ashok Sharma
Company: Projectiondesign
: Habornveien 53 / N-1630 Gamle Fredrikstad /
Norway
Line 1: (+47) 69 30 45 50
Fax: (+47) 69 30 45 80
M1 name: Ashok Sharma
Mobile 1: (0) 98 206 10 670
Email 1: ashok.sharma@projectiondesign.com

- Office 2000 Solutions for Draper products

First Name: Kamalakkannan / Azharuddin
Company: Office 2000 Solutions Pvt Ltd
: # 16, 19 & 20 - Block II / SIDCO Electronic Complex /
Guindy Industrial Estate /
600 032 Chennai, Tamilnadu
Line 1: (44) 22 50 07 74
Line 2: (44) 22 50 04 99
Line 3: (44) 45 53 22 80
Fax: (44) 22 50 05 50
M1 name: Kamal
Mobile 1: (0) 95 000 20 057
M2 name: Azharuddin
Mobile 2: (0) 95 000 20 053
Email 3: rekha@office2000.com
Email 1: kamal@office-2000.com
Email 2: azhar@office-2000.com

rekha@office-2000.com

Should you require more informations, please feel free to call us.

Best regards,



Didier Weiss

Sound Wizard
Pro Audio Acoustic Design

Shakti Area 9
Auroville 605 101 (Via Pondicherry)
Tamil Nadu, India
Phone (0) 413 262 26 59
Phone (0) 413 262 24 80

www.soundwizard.net

SOUND WIZARD
Shakti-Auroville 605 101
Tamil Nadu-India
Tel : 0413 2622659 Fax : 0413 2623410
Email : soundwiz@auroville.org.in
Website : www.soundwizard.net

1

Line 1: (80) 41 20 05 71
Line 2: (80) 41 20 05 72
Line 3: (80) 41 20 05 73
Fax: (80) 41 20 05 74
M1 name: Poncho
Mobile 1: (0) 93 437 71 035

- Rivera International for Denon & Pioneer products

First Name: Prasad Patil
Company: Rivera International
: # 7-397A-1B / Mangaldas House / Naaz Cinema Compound /
Lamington Road /
400 004 Mumbai, Maharashtra
Line 1: (22) 23 80 05 55
Fax: (22) 23 86 23 42
Mobile 1: (0) 93 225 32 349
Email 1: ppatils@gmail.com

- Promusicals for Samson & Alesis products

First Name: Apollo
Company: Pro Musicals - Apollo
: # 25 - Casa Major Road / Egmore /
600 008 Chennai, Tamil Nadu
Line 1: (44) 28 19 36 07
Line 2: (44) 28 19 34 45
Fax: (44) 28 19 38 23
M1 name: Apollo
Mobile 1: (0) 98 843 04 426
Email 1: apollo_promusic@vsnl.net

- Sun Media Ventures for cabling products

First Name: Umesh Ramdas Bhagwat
Company: SUN Media Ventures Ltd
: Flat no:1 - Ground Floor / Krishna Kunj / Ashok Nagar /
Cross Road No: 3 / Kandivli (East) /
400 101 Mumbai, Maharashtra
Line 1: (22) 28 84 37 72
Line 2: (22) 28 85 41 17
Fax: (22) 28 84 15 90
M1 name: Umesh
Mobile 1: (0) 98 210 38 990
M2 name: Peter
Mobile 2: (0) 98 214 36 550
Email 1: sunmedia@vsnl.com
Email 2: sunmedia.umesh@gmail.com

- Sassi Enterprises for Telex products

First Name: BalaRaman
Company: Sassi Enterprises
: New No: 90 - (Old No: 149) / "Nelson Plaza" /
Nelson Manickam Road / Choolaimedu /
600 094. Chennai, Tamilnadu
Line 1: (44) 23 74 67 61
Line 2: (44) 23 74 66 61

9

10

Sound Wizard

Acoustics & Pro-audio

Auroville, Oct 13th, 2009

Dear Sir, dear Madam,

As requested by you, we recommend the following parties to supply audio equipment for your main auditorium upgrade:

- Aditya Infotech for EAW & Audix products

First Name: Dhruv Datta
Company: Aditya Infotech Ltd
: #12-13 & 15-A - Janki Centre / 29 - Shah Industrial Estate /
Off. Veera desai road / Andheri (west) /
400 053 Mumbai
Line 1: (22) 26 74 15 95
Line 2: (22) 26 74 15 96
Line 3: (22) 26 74 15 98
Fax: (22) 26 74 15 00
M1 name: Dhruv Datta
Mobile 1: (0) 93 218 94 353
Email 1: dhruv_datta@adityagroup.com

- Ansata Computers for Digidesign products

First Name: Leslie J. Lean
Company: Ansata
: # 53 - C.K. Garden / Wheeler Road Extn /
560 084. Bengalooru, Karnataka
Line 1: (80) 25 46 51 44
Line 2: (80) 25 46 46 55
Fax: (80) 25 47 94 94
M1 name: Leslie
Mobile 1: (0) 99 003 17 537
Email 1: leslie.lean@ansata.net

- MRH Digital for QSC products

Last Name: QSC Business Head
First Name: Poncho (S. Gopinadhan)
Company: MRH Digital System Pvt. Ltd
: Skanda Krupa / # 191- 1st Cross / 38th Main /
BOOHBCS / BTM Layout II Stage /
560 068 Bengalooru, Karnataka

3

DESCRIPTION OF WORK AND MATERIALS	NAME OF THE SUPPLIERS	QUOTED VALUE In Rs.	POSITION	TOTAL COST AWARDED - L 1
4 For Denon & Pioneer Products	M/s.RIVERA International-Mumbai. 4	189187.50	L 1	189187.50
	M/s.Thump - Mumbai .18	200496.88	L 2	
	M/s.Audio control - Navi Mumbai.703	206082.50	L 3	
5 For Samson & Alesis Products	M/s.Pro Musicals- Chennai .8	228685.00	L 1	228685.00
	M/s.i Media international - Chennai.8	240110.00	L 2	
	M/s.Susan Electronics-Chennai.8	254080.00	L 3	
6 For Cabling products	M/s.Sun Media Ventures Pvt ltd, Mumbai101	762651.00	L 1	762651.00
	M/s.Frontiertech consultancy - Thane.603	843138.00	L 2	
	M/s.Envoy Marketing and Distributors-Mumbai 28.	900547.00	L 3	

(6)

	DESCRIPTION OF WORK AND MATERIALS	NAME OF THE SUPPLIERS	QUOTED VALUE In Rs.	POSITION	TOTAL COST AWARDED - L1
7	For Telex Products	M/s.Sasi Enterprises-Chennai.94	293370.75		293370.75
8	For Projection Design - Projectors	M/s. Projection Design Products Norway country 21400 USD \$ @Rs.45/USD	963000.00		963000.00
9	For Draper products	M/s.Office 2000 solutions pvt ltd, Guindy -Chennai 32.	463550.00		463550.00
10	For sound proofing work		1500000.00		1500000.00
11	Consultant charges		250372.00		250372.00
12	Implementation works to be done on site		12,64,125.00		1264125.00
13	Unforeseen items				1630000.00
14	Miscellaneous and Overheads				2789500.00
			Total	In Rupees	2,20,00,000.00

5

5

BID EVALUATION CRITERIA (BEC) FOR SOUND EQUIPMENT IN KOOTHAMBALAM

DESCRIPTION OF WORK AND MATERIALS	NAME OF THE SUPPLIERS	QUOTED VALUE in Rs.	POSITION	TOTAL COST AWARDED – L 1
1 Supplying of EAW & Audix products	M/s.Aditya InfoTech – Chennai .15	6186336.00	L 1	6186336.00
	M/s.Sriram Studio – Chennai 26	7159260.00	L 2	
	M/s.Proserve Business – Chennai.83	7476100.00	L 3	
2 For Digidesign products	M/s.Anasta computers – Bangalore.	3353951.25	L 1	3353951.25
	M/s.Audio Care – Chennai.116	3699292.50	L 2	
	M/s.Media Link Concepts – Chennai.26	3857625.00	L 3	
3 For supplying of QSC Products	M/s.MRH Digital systems-Mumbai. 7	844771.50	L 1	844771.50
	M/s.Calibre –Mumbai. 7	862425.00	L 2	
	M/s.Ankur electronics – Mumbai. 34	874912.50	L 3	

⑥

⑦

For Telex products, Digital Projector Design products and Draper products, we could not get competitive quotations. However, due to urgency of the work (this work has to be completed before the start of December festival), and the suppliers for other products have been identified, we may go for the supply for these products under the rates given by them, if approved please.

If approved, the suppliers quoted 'L 1' rates for the different products identified by BEC may be approved for issue of supply orders, terms and conditions specified therein.

Administrative approval may please be given for Rs.2.20 crores (Rupees two crore and twenty lakh only) for supply of these products initially. The detail for this administrative approval is given in Annexure II.

The working committee, after viewing the presentation made of various consultants, nominated Sri Ravi Nilakanta as a Consultant Architect for this job. The sound proofing (Acoustic Panel fixing) work will be undertaken through the contractor after obtaining the Bill of Quantities (BOQ) and specification from the consultant.

BEC also includes some sound proofing work, consulting charges and implementation of works to be done to give an inside view of the total amount involved for this work. However, along with sound equipment work, sound proofing works also to be taken side by side in consultation with M/s.Sound Wizard with the reputed contractors in the same field as identified by the consultant

General terms and conditions to be attached to the supply order to be given are also placed below for approval please.

Lala Sanjay
DIRECTOR 21/10'09

Shree... ..

P.T. Krishnan
P.T.Krishnan 6/11/09
(F)



C:\2009-2010\IV.Director\2.Official\Works.doc

31 October 2009

Sub: Up gradation of Sound system in Koothambalam - Reg

During the 32nd Governing Board meeting held on 7th April 2009, civil works an Advisory Committee was formed to advise the Director in finalizing various contracts towards works undertaken by Kalakshetra foundation during coming years.

One of the major works, which was highlighted by the Secretary, Ministry of Culture, and New Delhi during the visit to Kalakshetra in September 2009, is up gradation of Sound equipment in Koothambalam. For executing this work, simultaneously along with working committee, M/s. Sound Wizard, an expert in sound equipment installations was also engaged as a expert advisor for this project. The selection of Sound Wizard as an expert advisor for the procurement of this equipment was also made a mention to the Governing Board.

For supply of Audio equipments in Koothambalam, Sound Wizard the technical experts has obtained various quotations for the materials required for the job. Based on the quotations received, we have now formalized Bid Evaluation Criteria (BEC) for supply of audio equipments to Koothambalam. From the BEC, it is proposed to issue supply orders to suppliers whose quotation is 'L 1' and who have been certified by M/s. Sound Wizard as the best supplier for the job at the rates specified in the BEC.

..... 2

3



Dear Leela,

I have spoken to your CAO.

They will have the LI. Suppliers
agree to the delivery location,
Insurance + final payment
after inspection and confirm
the same to them in a
separate letter.

The note has been signed.

With kind regards.

P. J.

6.10.09

9

1

13/10/09

Sound Wizard

Acoustics & Pro-audio

Shakti Area 9, Auroville 605 101 (via Pondicherry), Tamil Nadu, INDIA
Phone +91 (0) 413 2622 659, -480, -482 <http://www.soundwizard.net>

To:

Kalakshetra Foundation - Rukmani Devi College of Fine Arts
Kalakshetra Road, Thiruvanmiyur
600 041 Chennai
Tamil Nadu, INDIA

Date: 09 October, 2009

Subject: Responsibility for equipment specification compliance and installation.

Dear Ms. Leela Samson,

Sound Wizard will be responsible to aid the Kalakshetra Foundation to ensure that all audio video equipment for the renovation of the auditorium is supplied and installed as our specifications.

Our support will cover:

- Receipt of materials as per the specification
- Inspection of quality and condition of the equipments
- Confirmation of quantity
- Testing and certification of equipment
- Supporting installation for all the acoustical works
- Supervision for all audio video equipment installation
- Technical supervisor may be deputed for checking level
- Certification of payment to the supplier/agency/contractor

Equipment supply order should be placed directly to the agencies after discussing the payment conditions and mode of the despatch / delivery of materials to your site.

At your service for any clarification.

Sincerely,

For Sound Wizard



Kumbha Young Grenier

10



॥ श्रीहरिः ॥

ADITYA INFOTECH LTD.

Flat No. 3, City Star, Millenium Tower, 2nd Floor, 29, Temple Avenue,
Srinagar Colony, Saidapet, Chennai - 600 015

Tel. : (044) 22351996, 97, 32984914 Fax : (044) 22351996

E-mail : aditya_chen@adityagroup.com Website : www.adityagroup.com



Date: 14-09-2009

Ref No: AIL/CHN/1409/001

To,
The Director,
Kalakshetra Foundation,
Thiruvamyur,
Chennai - 600 041

KIND ATTENTION MS. Leela Samson

Dear Madam,
As required, Please find below the Price for EAW and Audix Products.

S.No	UNIT	Quantity	Price Per Unit (INR)	VAT (%)	Unit Value excluding VAT
1	EAW NTL 720 Line Array	10	335750.00	12.5	3357500.00
	EAW NTS22 Subwoofer	2	246625.00	12.5	493250.00
3	EAW FB172 Fly Bar for NTL 720	2	140875.00	12.5	281750.00
4	EAW KF750 Cables - FC700C	2	15250.00	12.5	30500.00
5	EAW UB52i Loudspeaker	4	64750.00	12.5	259000.00
6	EAW VR61 Front Fill Speaker	20	26750.00	12.5	535000.00
7	EAW CAZ1400 Amplifier	6	34000.00	12.5	204000.00
8	Audix Micropod 18HC Gooseneck Microphone	3	22125.00	4.0	66375.00
9	Audix W3-OM5 Handheld Transmitter with Mic	4	44000.00	4.0	176000.00
10	Audix W3-BP Body Pack System	4	35750.00	4.0	143000.00
11	Audix HT5-BG Slim Line Headphone Microphone	4	16875.00	4.0	67500.00
12	Audix ADX10-P Lavalier Microphone	4	10875.00	4.0	43500.00
13	Audix W3-BP Body Pack System	4	35750.00	4.0	143000.00
14	Audix APS-911 Battery/Phantom Power Adapter	4	3750.00	4.0	15000.00
15	Audix WS10S External Wind Screen	4	950.00	12.5	3800.00
16	Audix MC10L Metal Clip	4	1045.00	12.5	4180.00
Total Value Excluding VAT					5823355.00
Discount (5%) (-)					5546052.38
VAT - 12.5% (+)					615354.70
VAT - 4% (+)					24928.57
GRAND TOTAL					6186335.65

Rupees Sixty One Lakhs Eighty Six Thousand Three Hundred & Thirty Five Rupees and Sixty Five Paise Only

Terms & Conditions:

1. Payment Terms: 50% Advance along with the Purchase Order and 50% on Delivery
2. Delivery Terms: 12-16 Weeks on receipt of PO and Advance
3. Warranty: As per respective Manufacturers guidelines

For Aditya Infotech Ltd

Vishal .B. Joshi

Regional Sales Manager - Audio



Delivery where?
Installation charges.
Insurance during
transit + erection.
Inspection of
equipment
on delivery. 2/33
30

For SOUND WIZARD

Executive

supply - reg

from **Works kalakshetra** <works@kalakshetra.in>
to dhruv_datta@adityagroup.com
date Fri, Nov 6, 2009 at 3:42 PM
subject supply - reg
mailed-by kalakshetra.in

hide details 3:42 PM (3 ho

Ref: your quotation No. AIL/CHN/1409/001 Dated 14.09.2009

This is in continuation of your quotation for supply of EAW and Audix products to the Kalakshetra Four to-day seeking your confirmation for certain issues on this.

Kalakshetra Foundation being a central government organization had to follow procedures laid down b India. Accordingly the following stipulations are proposed before the supply order is formally issued:

i. Generally, no advance payment will be given. If required, the conditions laid down in General Financial Rule
ii. The materials should be delivered at our premises (door delivery) and materials should be covered with Ins Kalakshetra Foundation/Chennai. The material delivered should be in original packing WITHOUT tampering w manufacturer's packing and in good condition.

iii. The final payment will be disbursed after the material is approved and certified by the consultant - M/s.Sou
Please convey your concurrence to the above by return email to this office immediately
Kalakshetra Foundation

12

13

Re: supply - No. AIL/CHN/1409/001 Dated 14.09.2009 Inbox X

from **Dhruv Datta** <dhruv_datta@adityagroup.com> hide details 5:03 PM (18 ho
to Works kalakshetra <works@kalakshetra.in>
cc Vishal Joshi <vishal_joshi@adityagroup.com>
date Fri, Nov 6, 2009 at 5:03 PM
subject Re: supply - No. AIL/CHN/1409/001 Dated 14.09.2009
mailed-by eigbox.net

Dear Sir/Madam,

Further to your email of this afternoon please find below our views.

- 1> **We would need an advance of at least 50% before we can move things forward from our end, as it is level best to honor our earlier pricing proposal even though our principals EAW have increased prices**
- 2> **We are in agreement to your request for Door Delivery with CIF taken care of.**
- 3> **We are in agreement to this condition as well.**

Regards,

Dhruv Datta
(Business Development Head Audio/Video),
Aditya Infotech Ltd,
Mobile: +91 9321894353
Skype: dhruvdatta
Email: dhruv_datta@adityagroup.com
web: [www.adityagroup](http://www.adityagroup.com)

13

14

Re: supply - No. AIL/CHN/1409/001 Dated 14.09.2009
InboxX

Reply
|Dhruv Datta to me, Vishal
show details 5:03 PM (18 hours ago)

from Dhruv Datta <dhruv_datta@adityagroup.com>
to Works kalakshetra <works@kalakshetra.in>

cc Vishal Joshi <vishal_joshi@adityagroup.com>

date Fri, Nov 6, 2009 at 5:03 PM
subject Re: supply - No. AIL/CHN/1409/001 Dated 14.09.2009
mailed-by eigbox.net

hide details 5:03 PM (18 hours ago)

Dear Sir/Madam,

Further to your email of this afternoon please find below our views.

- 1> We would need an advance of at least 50% before we can move things forward from our end, as it is we are trying our level best to honor our earlier pricing proposal even though our principals EAW have increased prices globally by 20%.
- 2> We are in agreement to your request for Door Delivery with CIF taken care of.
- 3> We are in agreement to this condition as well.

Regards,

Dhruv Datta
(Business Development Head Audio/Video),
Aditya Infotech Ltd,
Mobile: +91 9321894353
Skype: dhruvdatta
Email: dhruv_datta@adityagroup.com
web: www.adityagroup.com

14

7-11-09.
Chennai

To,
The Director,
Katakshetra Foundation,
Chennai.

Ref: Your Email dated 06.11.09.
Quotation No: AL/CHN/1409/001 dated 14.09.09.

Dear Sir/Madam,

with reference to your email, please find below
our views on the same.

1. We would need an advance of atleast ~~30%~~ ^{30%} to move things forward from our end, as our principals have increased Prices globally by 20%.
2. We are in agreement to your request for Door Delivery with CIF taken care of.
3. We are in agreement to the condition for final payment after approval & certification by the consultant.

At the same time, we shall try to get the delivery by 8-10 weeks, which can be confirmed within 1 week of the Order & ~~20%~~ Advance.

Regards,

(Regional Sales Manager - Audio)

15

15

C:\ 2009-2010\V.Admin\2. Engineering\i.Plan\d.Sound systems\koothambalam.doc	07 November 2009
--	------------------

Sub: Up gradation of Sound system in Koothambalam – supply order – Reg.

Ref: Work committee approval dated 6.11.2009
M/s.Aditya infotech letter dated 7.11.2009.

Based on the approval by the Works Committee and further clarification obtained from the M/s.Aditya Infotech limited in writing dated 07.11.2009, the supply order to be placed on the supplier is put up below for approval.

As per supply order condition 30% of the supply order for Rs. 18, 55,000/- (Rs. 6186336) has to be paid to the supplier, subject to producing the Bank guarantee by him.

Supply order for the same may be approved and sanction for the payment of advance may please be approved please.

EO

AO
for

CAO

DIRECTOR

C:\ 2009-2010\V.Admin\2. Engineering\i.Plan\d.Sound systems\koothambalam.doc	07 November 2009
--	------------------

M/s.Aditya Infotech Limited,
 No,20 Kothari Road,
 Nungambakkam,
 Chennai 600 034.

Sir(s)

Sub: Supply of EAW & Audix products – supply order - reg

Ref: Your offer No. AIL / CHN / 1409 /001 dated 14.09.2009
 Your letter dated 07.11.2009

The Director, Kalakshetra Foundation is pleased to award the Supplying of EAW Audix Products at a total cost of Rs. 6186336/- as per the Annexure specification, terms and condition, enclosed herewith in all respects. This is a firm rate contract. No escalation will be paid on account.

As per the terms, an advance amount of Rs.18, 55,000/- vide cheque No. Dated drawn in canara bank /Thiruvanmiyur branch in favour of M/s.Aditya infotech limited is enclosed herewith subject to produce of the Bank Guarantee by the supplier.

The final payment will be disbursed after the material is approved and certified by the consultant - M/s.Sound wizard

Delivery time – 8 to 10 weeks from the date of supply order till 20. 01.2010.

Warrant as specified in the conditions

The materials should be delivered at our premises (door delivery) and materials should be covered with Insurance up to Kalakshetra Foundation/Chennai.

The material delivered should be in original packing WITHOUT tampering with the original manufacturer's packing and in good condition.

The above supply order should be effected and completed in all respects by 20.01.2010.If the progress of the supply is found to be not satisfactory or the supply is not completed in all respects as per the schedule as mentioned above, this supply order will automatically cease without notice and without assigning any reason and you have to return the advance amount with interest at the rate of 12% P.A.

Kindly acknowledge receipt of the letter.

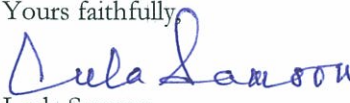
Yours faithfully,

 Leela Samson
 Director

Date for approval

[Handwritten initials]

@
 A0

↓
 CAO

(17)

(21)



रसो वै सः

18

kalakshetra

F O U N D A T I O N

C:\ 2009-2010\V.Admin\2. Engineering\i.Plan\d.Sound systems\koothambalam.doc

07 November 2009

M/s.Aditya Infotech Limited,
No,20 Kothari Road,
Nungambakkam,
Chennai 600 034.

Sir(s)

Sub: Supply of EAW & Audix products – supply order - reg

Ref: Your offer No. AIL / CHN / 1409 /001 dated 14.09.2009
Your letter dated 07.11.2009

The Director, Kalakshetra Foundation is pleased to award the Supplying of EAW Audix Products at a total cost of Rs. 6186336/- as per the Annexure specification, terms and condition, enclosed herewith in all respects. This is a firm rate contract. No escalation will be paid on account.

As per the terms, an advance amount of Rs.18, 55,000/- vide cheque No. Dated drawn in canara bank /Thiruvanmiyur branch in favour of M/s.Aditya infotech limited is enclosed herewith subject to produce of the Bank Guarantee by the supplier.

The final payment will be disbursed after the material is approved and certified by the consultant - M/s.Sound wizard

Delivery time – 8 to 10 weeks from the date of supply order till 20. 01.2010.

Warrant as specified in the conditions

The materials should be delivered at our premises (door delivery) and materials should be covered with Insurance up to Kalakshetra Foundation/Chennai.

The material delivered should be in original packing WITHOUT tampering with the original manufacturer's packing and in good condition.

The above supply order should be effected and completed in all respects by 20.01.2010.If the progress of the supply is found to be not satisfactory or the supply is not completed in all respects as per the schedule as mentioned above, this supply order will automatically cease without notice and without assigning any reason and you have to return the advance amount with interest at the rate of 12% P.A.

Kindly acknowledge receipt of the letter.

Yours faithfully,

Leela Samson

Leela Samson
Director

Founder : Smt. Rukmini Devi Chairman : Justice Sri S. Mohan Former Judge Supreme Court
Director : Ms Leela Samson Member Secretary : Sri R.V. Ramani Governing Board

18

Kalakshetra Foundation Thiruvanmiyur Chennai 600 041
Tel: 0091-(0)44-2452 0836 / 4057 / 1844 Fax : 0091-(0)44-2452 4359
Email : info@kalakshetra.in Website : www.kalakshetra.in



Kalakshetra

F O U N D A T I O N

C:\2009-2010\V.Admin\2. Engineering\i.Plan\d.Sound systems\koothambalam.doc

07 November 2009

M/s.Aditya Infotech Limited,
No,20 Kothari Road,
Nungambakkam,
Chennai 600 034.

Sir(s)

Sub: Supply of EAW & Audix products – supply order - req

Ref: Your offer No. AIL / CHN / 1409 /001 dated 14.09 2009
Your letter dated 07.11.2009

The Director, Kalakshetra Foundation is pleased to award the Supplying of EAW Audix Products at a total cost of Rs. 6186336/- as per the Annexure specification, terms and condition, enclosed herewith in all respects. This is a firm rate contract. No escalation will be paid on account.

As per the terms, an advance amount of Rs.18, 55,000/- vide cheque No. Dated drawn in canara bank /Thiruvanmiyur branch in favour of M/s.Aditya infotech limited is enclosed herewith subject to produce of the Bank Guarantee by the supplier.

The final payment will be disbursed after the material is approved and certified by the consultant - M/s.Sound wizard

Delivery time – 8 to 10 weeks from the date of supply order till 20. 01.2010.

Warrant as specified in the conditions

The materials should be delivered at our premises (door delivery) and materials should be covered with Insurance up to Kalakshetra Foundation/Chennai.

The material delivered should be in original packing WITHOUT tampering with the original manufacturer's packing and in good condition.

The above supply order should be effected and completed in all respects by 20.01.2010.If the progress of the supply is found to be not satisfactory or the supply is not completed in all respects as per the schedule as mentioned above, this supply order will automatically cease without notice and without assigning any reason and you have to return the advance amount with interest at the rate of 12% P.A.

Kindly acknowledge receipt of the letter.

Yours faithfully,

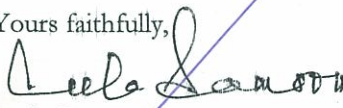
Leela Samson
Director

10-11-09

To,
The Director,
Kalakshetra foundation,
Chennai

Ref: C:\2009-2010\U. Admin\2. Engineering\i. plan\d. Sound
Systems\koothambalam.doc dated 07.11.09.

Dear Sir,

With reference to the above mentioned work order for supply of EAW and Audix products, we would not require 30% Advance as requested in our letter dated 07.11.09.

However, we shall deliver the equipments in part shipments and on approval of the consultant - M/s Sound wizard, we shall collect the payment of the units invoiced to Kalakshetra foundation on shipment basis.

We assure to deliver the materials by 20.01.2010. We shall keep you updated if there is any delay in delivery due to reasons beyond our control.

Kindly acknowledge the receipt of the letter.

Thanking you,



Vishal. B. Joshi
Regional Sales Manager - Audio.

20

New communication Address Inbox X

from **Vishal Joshi** <vishal_joshi@adityagroup.com>
to Vishal Joshi <vishal_joshi@adityagroup.com>
date Fri, Oct 9, 2009 at 3:15 PM
subject New communication Address
mailed-by eigbox.net

[hide deta](#)

Hi,

We are glad to inform you that we have shifted our Chennai branch office to a new premises at Nungar immediate effect. All communications can be done at the below mentioned address.

Aditya Infotech Ltd
No 20, Kothari Road,
Nungambakkam,
Chennai - 600034
Phone - 91-44-28261996/97

Thanks & Regards,

=====

Vishal .B. Joshi
Regional Sales Manager - Audio
Ph: 09384608113
Email: vishal_joshi@adityagroup.com
Aditya Infotech Ltd
Address - 20, Kothari Road, Nungambakkam, Chennai - 34
Phone - 91-44-28261996/97
Website: www.adityagroup.com

=====

21

~~Annexure to~~
Revised supply order

C:\ 2009-2010\V.Admin\2. Engineering\i.Plan\d.Sound systems\koothambalam.doc	09 November 2009
--	------------------

M/s. ANSATA COMPUTER SYSTEMS PRIVATE LIMITED,
 No - 53, C.K. Garden, Wheeler Road Extension,
 Bangalore - 560 084,
 Karnataka state.

M/s. Aditya Infotech Ltd,
 Chennai . 600 034.

Sir(s)

Sub: Supply of Digidesign Products - supply order - reg

Ref: Your offer No. ACS / 2015 dated 22 July, 2009.
 Our email dated 06.11.2009
 Your email acceptance dated 09.11.2009

The Director, Kalakshetra Foundation is pleased to award the Supplying of ^{Digit Design} ~~Digit Design~~ Products at a total cost of Rs. 6186336/- Nett, as per the Annexure specification, terms and condition, enclosed herewith in all respects. This is a firm rate contract. General term and conditions applicable to this order is attached.

The final payment will be disbursed after the material is approved and certified by the consultant - M/s.Sound wizard

Delivery time - 10 weeks from the date of supply order till 20.01.2010.

Warrant as specified in the conditions

The materials should be delivered at our premises (door delivery) and materials should be covered with Insurance up to Kalakshetra Foundation/Chennai

The material delivered should be in original packing WITHOUT tampering with the original manufacturer's packing and in good condition.

The above supply order should be effected and completed in all respects by 20.01.2010. **If the progress of the supply is found to be not satisfactory or the total supply is not completed in all respects as per the schedule as mentioned above, this supply order will automatically cease without notice and without assigning any reason.**

Kindly acknowledge receipt of the letter.

Leela Samson
Director

DRAFT for approval

[Signature]
EO

[Signature]
10/11
AO

[Signature]
CAO

[Signature]
DIRECTOR 11/11/09

22 a

Original supply order
 Copy placed below for signature
 please

C:\ 2009-2010\V.Admin\2. Engineering\i.Plan\d.Sound systems\koothambalam.doc	10 November 2009
--	------------------

Sub: Up gradation of Sound system in Koothambalam – supply order – Reg.

Ref: Work committee approval dated 6.11.2009 P 2
 M/s.Aditya InfoTech letter dated 7.11.2009. – P 15
 Revised letter from M/s.Aditya InfoTech letter dated 7.11.2009. – P 20
 Approval note dated 07.11.2009 - P 16

Based on the approval by the Works Committee and further clarification obtained from the M/s.Aditya InfoTech limited in writing dated 07.11.2009, the supply order to be placed on the supplier is put up below for approval.

As per supply order condition 30% of the supply order for Rs. 18, 55,000/- (Rs. 6186336) **has to be paid to the supplier, subject to producing the Bank guarantee by him.**

The supply order is kept ready to issue to the supplier and the supplier now requested not required 30% advance to implement the supply order. They take up the supply order immediately and assured to deliver the materials.

The revised supply order is submitted for approval please.

Submitted for information and approval please.

EO

10/11
AO

CAO

 11/11/09
DIRECTOR







Sl. No.	Unit	Qty.	Price Per unit (INR)	VAT (%)	Unit Value Excluding VAT
1	EAW NTL 720 Line Array	10	3,35,750/-	12.5	33,57,500-00
2.	EAW NTS22 Subwoofer	2 ✓	2,46,625/-	12.5	4,93,250-00
3.	EAW FB172 Fly Bar for NTL 720	2 ✓	1,40,875/-	12.5	2,81,750-00
4.	EAW KF 750 Cables - FC700C	2	15,250/-	12.5	30,500-00
5.	EAW UB52i Loudspeaker	4	64,750/-	12.5	2,59,000-00
6.	EAW VR61 Front Fill Speaker	20	26,750/-	12.5	5,35,000-00
7.	EAW CAZ 1400 Amplifier	6	34,000/-	12.5	2,04,000-00
8.	Audix Micropod 18HC Gooseneck Microphone	3	22,125/-	4.0	66,375-00
9.	Audix W3-OM5 Handheld Transmitter with Mic	4	44,000/-	4.0	1,76,000-00
10.	Audix W3-BP Body Pack System	4	35,750/-	4.0	1,43,000-00
11.	Audix HT5-BG Slim Line Headphone Microphone	4	16,875/-	4.0	67,500-00
12.	Audix ADX 10-P Lavalier Microphone	4	10,875/-	4.0	43,500-00
13.	Audix W3-BP Body Pack System	4	35,750/-	4.0	1,43,000-00
14.	Audix APS-911 Battery Phantom Power Adapter	4	3,750/-	4.0	15,000-00
15.	Audix WS10S External Wind Screen	4	950/-	12.5	3,800-00
16.	Audix MC 10L Metal Clip	4	1,045/-	12.5	4,180-00
Total Value Excluding VAT					58,23,355-00
Discount 5% (-)					55,32,187-00
VAT 12.5% (+)					6,13,816-38
Vat 4% (+)					24,866-25
GRAND TOTAL					
(Rupees sixty one lakhs seventy thousand eight hundred and thirty four only)					61,70,869-63
Rounded to					Or 61,70,870-00

To

M/s. Aditya Infotech Ltd.,
Chennai-

24



C:\2009-2010\V.Admin\2. Engineering\i.Plan\d.Sound systems\koothambalam.doc

09 November 2009

M/s. Aditya Infotech Limited,
No, 20 Kothari Road,
Nungambakkam,
Chennai 600 034.

Sir(s)

Sub: Supply of EAW & Audix Products -- Supply order - Reg

Ref: Your offer No. AIL / CHN / 1409 / 001 dated 14.09.2009
Your letter dated 07.11.2009
Your letter dated 10.11.2009

The Director, Kalakshetra Foundation is pleased to award the Supplying of EAW & Audix Products at a total cost of Rs. 61, 70,870/- Nett, as per the Annexure specification, terms and condition, enclosed herewith in all respects. This is a firm rate contract. General term and conditions applicable to this order is attached.

The final payment will be disbursed after the material is approved and certified by the consultant - M/s. Sound wizard.

Delivery time -- 10 weeks from the date of supply order till 20.01.2010

Warrant as specified in the conditions.

The materials should be delivered at our premises (door delivery) and materials should be covered with Insurance up to Kalakshetra Foundation/Chennai.

The material delivered should be in original packing WITHOUT tampering with the original manufacturer's packing and in good condition.

The above supply order should be effected and completed in all respects by 20.11.2010. If the progress of the supply is found to be not satisfactory or the total supply is not completed in all respects as per the schedule as mentioned above, this supply order will automatically cease without notice and without assigning any reason.

Kindly acknowledge receipt of the letter.

Leela Samson
Director

Received a copy of the work order.

13/11/09

(25)

168

198

18/0/11

Insured } M/S. HDI ITA INFOTECH LIMITED.
 पाने वाले का नाम } NO. 20, Kothari Road,
 Addressed to (Name) } Nungambakkam,
 † बीमा का मूल्य (रुपयों में) } CHENNAI - 600034.
 † Insured for Rupees

वितरण की तारीख / Date of delivery 20

- * अनावश्यक को काट दिया जाए।
- * Score out the matter not required.
- † केवल बीमा वस्तुओं के लिए।
- † For Insured articles only.

2/19/09

DITYA INFOTECH LIMITED
 NO. 20, KOTHARI ROAD,
 NUNGAMBAKKAM,
 CHENNAI - 600034.

पाने वाले के हस्ताक्षर / Signature of addressee

26

008

881

की नाम मोहर
 Name stamp of
 office of posting



तारीख-मोहर



Date-Stamp

भेजने वाले
 का पता
 Sender's
 Address

KALAKSHETRA FOUNDATION
THIRUVANMIYUR
CHENNAI-600



पिन/PIN

--	--	--	--

26



॥ श्रीहरिः ॥
PACKAGING SLIP



S. No. : **5228**

M/s. **KALASHETRA** Against B/No.

FOUNDATION Date **25/1/08**

DW/0920 No. of Cartons.

ITEM	SERIAL No.	SERIAL No.
66005 FAWNTL 720 LINEARRAY 8 Nos	AKD1247	1272
	1276	1264
	1263	1259
	1284	1265
66017 FAW NTS 22 BLACK 2 Nos	ACU10152	
	" 10144	
66019 FAW PBLA2 PLYBAN 2 Nos	ARC 1004	
	" 1002	

Lot Code.....

Prepared By.....

Signature *[Signature]*

[Handwritten mark]

[Handwritten mark]

TAX INVOICE

(Original)

25

Aditya Infotech Ltd.-Chennai - (From 1-Apr-2009) Flat No.3, 2nd Floor, City Star Millenium Tower No.29, Temple Avenue, Srinagar Colony Sidapet, Chennai - 600015 TIN No. 33130862932 C.S.T No. 837197 SERVICE TAX NO.:AABCA1601RST009	Invoice No. AIL/CHN/TX/09-10/0920
	Invoice Date 25-Nov-2009
	Delivery Note No. & Date :
	Order No. & Date : C:/2009-2010 Dt. 9-Nov-2009
	Despatch Document No. :

Bill To KALASHETRA FOUNDATION THIRUVANMIYUR CHENNAI - 600041 PH. 044-24520826 / 4057 TIN No. :	Ship To KALASHETRA FOUNDATION THIRUVANMIYUR CHENNAI - 600041 PH. 044-24520826 / 4057 TIN No. :
--	--

ADITYA INFOTECH LIMITED
 No: 20, KOTHARI ROAD,
 HUNGAMBAKKAM,
 CHENNAI - 600 034.
 TIN No: 33130862932
 CST No: 837197

Dealer Name : Kalashetra Foundation	End User Name :	Despatched through DELIVERED
Supplier's Ref.	Destination CHENNAI	Mode/Terms of Payment
Other Reference(s)	Terms of Delivery	



S.No.	Description of Goods	Quantity	Rate	per	Amount
1	66005 EAW NTL 720 LINE ARRAY	8 Pcs	3,35,750.00	Pcs	26,86,000.00
2	66017 EAW NTS22 BLACK	2 Pcs	2,46,625.00	Pcs	4,93,250.00
3	66019 EAW FB172 FLYBAR	2 Pcs	1,40,875.00	Pcs	2,81,750.00
	ORDER REF.NO.C:/2009-2010/V. ADMIN/ENGINEERING/I.PLAND.SOUND SYSTEMS/KOOTHAMBALAM.DOC DT.09.11.2009.				
	Less :				
	SECURITY Dept. KALASHETRA FOUNDATION THIRUVANMIYUR, CHENNAI - 600 041.				
	Trade Discount (-)5 %				(-1,73,050.00)
	Output VAT 12.5%				4,10,993.75
	Round Off Sales				0.25
	Total	12 Pcs			36,98,944.00

Amount Chargeable (in words)
Rs. Thirty Six Lakh Ninety Eight Thousand Nine Hundred Forty Four Only

TERMS & CONDITIONS

- All contracts shall be deemed to have been entered into at Delhi and in case of any dispute all proceedings if any shall be filed and litigated in the civil courts of Delhi and no where else.
- Our responsibility ceases the moment goods leave our godown. And goods once sold will not be taken back.
- We are not responsible for any delay or deterioration/breakage due to negligence of the carriers etc.
- In case of any variation in quality/quantity, the entire material must be kept separate for our verification. No claims or deduction will be acceptable without our verification. In case material is sold prior to our inspection no claim will be acceptable.
- The customer/consumer will not hold Aditya Infotech Ltd.-Chennai - (From 1-Apr-2009) responsible for, or liable for, any civil, criminal action, claims, demands, losses, damages, costs, charges and expenses, which customer/consumer may suffer, sustain or incur after the delivery of goods.
- In the absense of proper sales tax certificate, if not already sent, the sales tax as applicable along with any panel charges shall be recoverable.
- It is hereby informed that Aditya Infotech Ltd.-Chennai - (From 1-Apr-2009) is a marketing and distribution company and is not manufacturer, warranty, if any on the goods sold will be covered as per the policy and terms & conditions of the manufacturer.
- Any increase in excise duty/tax/octroi or any other government levy will be charged extra from the customer.
- Payment against this invoice will not be held for any pending claims of whatsoever nature.
- Payment by A/c payee cheque/demand draft. Outstation payment to be made by demand draft only.
- A charge of Rs. 250 plus interest @24% per annum shall be levied extra against each bouncing of cheque besides civil/criminal action.
- Overdue interest shall be charged @24% from the date of the bill.
- While making payment please quote our Invoice no.
- Rates subject to revision without any prior notice.
- Protest waived.

For Aditya Infotech Ltd.-Chennai - (From 1-Apr-2009)

 Authorised Signatory

Prof. Subrat Goyal
 25/11/09 - 1.45 PM

All ^{the} materials ^{has} as per specification
has been checked. Approved for
payment.



For Sound Wizard
26-11-2009

CP
26/11/09

SOUND WIZARD
Shakti-Auroville 605 101
Tamil Nadu-India
Tel : 0413 2622659 Fax : 0413 2623410
Email : soundwiz@auroville.org.in
Website : www.soundwizard.net

29

from **Didier** <didier@soundwizard.net>

[hide detail](#)

to "Leela Samson ." <leelasamson@gmail.com>
cc "Kalakshetra - Srinivasan ."
<works@kalakshetra.in>,
"-Kumbha SW ." <kumbha@soundwizard.net>,
"-Fabien ." <fabien@soundwizard.net>
date Tue, Nov 24, 2009 at 4:37 PM
subject First batch of equipment to check

Dear all at Kalakshetra,

Got a call from Aditya Infotech in order to test the major part of the shipment.
We could come Thursday 26th morning for full testing purposes, if it is fine with you.

We would need the shipment to be there on location (still packed) in a room where we can make a "little" bit of hours...

Please revert if it is OK with you, we could come around 9AM.

Waiting for your feedback in order to get organized.

Warm Regards

Didier

Sound Wizard
Acoustics & Pro-audio

Shakti #9
Auroville 605 101
Tamil Nadu, India
Phone (0) 413 262 26 59
Phone (0) 413 262 24 80
Phone (0) 413 262 24 82
Fax (0) 413 262 34 10

<http://www.soundwizard.net>

30

from Works kalakshetra <works@kalakshetra.in>

hide detail

to Didier <didier@soundwizard.net>
date Wed, Nov 25, 2009 at 2:49 PM
subject Re: First batch of equipment to check
mailed-by kalakshetra.in

Dear Didier,

Today 2.00 pm - M/s. Aditya Infotech have delivered the following materials (part) and kept in the old central office/ Kalakshetra Foundation.

- EAW NTL 720 Line Array - 8 pcs
- EAW NTS22 BLACK - 2 pcs
- EAW NTL FB172 FLYBAR - 2 pcs

Tomorrow morning 9.00 am - we may have the testing of the materials at old central office where we stacked.

Regards
V. Srinivasan
Kalakshetra Foundation
- Show quoted text -

For information please .

[Handwritten signature]

[Handwritten signature]

[Handwritten signature]

*Arul
DIRECTOR 25/11/09*

(31)

904

C:\ 2009-2010\V.Admin\2. Engineering\i.Plan\d.Sound systems\koothambalam.doc	26 November 2009
--	------------------

Sub: Up gradation of Sound system in Koothambalam – Supply of EAW & Audix Products – Payment – Approval of – Reg.

Ref: Work committee approval dated 6.11.2009 - P 02
 M/s.Aditya InfoTech letter dated 7.11.2009. - P 15
 Revised letter from M/s.Aditya InfoTech letter dated 7.11.2009. - P 20
 Approval note dated 07.11.2009 - P 16

Based on the approval by the Works Committee, as recommended by the consultant M/s.Sound wizard the supply order for supplying of EAW and AUDIX Products was entrusted to M/s.Aditya InfoTech limited at a total cost of Rs.61,70,870/- as per the specification given by the consultant.

One shipment equipments as part of supply order, was delivered by the M/s.Aditya Infotech to the foundation for the value of Rs.36, 98,944/- (Rupees thirty six lakhs ninety eight thousand nine hundred and forty four only).

P. 25

Further, our consultant had inspected and certified that the all (delivered) materials as per the specification and checked and recommended the payment to the supplier in backside of the invoice copy of the supplier.

P. 25

To M/s.Aditya Infotech Limited
 Vide Invoice No.AIL/CHN/TX/09-10/0920 dated 25.10.2009 ... 36, 98,944/-

Submitted for approval, please.

[Signature]
EO

[Signature]
AO 26.11.09
[Signature]

[Signature]
AO

[Signature]
DIRECTOR

[Circular Stamp]

[Handwritten Mark]

30

from **Didier** <didier@soundwizard.net>

[hide detail](#)

to Works kalakshetra <works@kalakshetra.in>
cc Fabien <fabien@soundwizard.net>,
"-Kumbha SW ." <kumbha@soundwizard.net>
date Wed, Nov 25, 2009 at 4:46 PM
subject Re: sound equipment ist batch - testing

Dear Mr. Srinivasan,

We will be there at the office, waiting for somebody to guide us to the place.
All the best,

Didier
- Show quoted text -
Sound Wizard
Acoustics & Pro-audio

Shakti #9
Auroville 605 101
Tamil Nadu, India
Phone (0) 413 262 26 59
Phone (0) 413 262 24 80
Phone (0) 413 262 24 82
Fax (0) 413 262 34 10

<http://www.soundwizard.net>

35

supply order-pending materials - reg

from Works kalakshetra <works@kalakshetra.in>
to vishal_joshi@adityagroup.com
date Wed, Jan 6, 2010 at 11:33 AM
subject supply order-pending materials - reg
mailed-by kalakshetra.in

[hide details](#) 11:33 AM (0 minu

Sir/s,

Supplying of EAW & Audix Products was entrusted and
The entire supply should be completed by 20.10.2010, as
per the work order.

Sofar, we have received part materials from which, one equip
ment has to be replaced or set right as decided by consultant.

Let us know your position by return email please.

Regards,

V.Srinivasan
kalakshetra

(34)

from Vishal Joshi <vishal_joshi@adityagroup.com>

[hide deta](#)

to Works kalakshetra <works@kalakshetra.in>

cc Dhruv Datta <dhruv_datta@adityagroup.com>

date Thu, Jan 7, 2010 at 1:55 PM

subject Re: supply order-pending materials - reg

mailed-by eigbox.net

Dear Sir,

We are extremely sorry for the delay in reply.

has to be ~~ser~~ Please be rest assured that we shall complete the order as per the order guidelines. Also the one equipment which will be done simultaneously.

We shall keep you updated if there is any delay from our end..

Thanks & Regards,

=====

Vishal .B. Joshi
Regional Sales Manager -Professional Audio/Video
Ph: 09384608113
Email: vishal_joshi@adityagroup.com
Aditya Infotech Ltd
 Address – 20, Kothari Road, Nungambakkam, Chennai - 34
 Phone - 91-44-28261996/97
 Website: www.adityagroup.com

=====

- Show quoted text -

[Reply](#) [Reply to all](#) [Forward](#)

(35)

from Vishal Joshi <vishal_joshi@adityagroup.com>
 to Works kalakshetra <works@kalakshetra.in>
 cc Dhruv Datta <dhruv_datta@adityagroup.com>
 date Fri, Jan 8, 2010 at 1:38 PM
 subject Re: supply order-pending materials - reg
 mailed-by eigbox.net

hide details

Dear Sir,

We shall get back to you by Monday on the date of Delivery for EAW and Audix Products as we are awaiting **critical** information from the Vender.

Thanks & Regards,

=====

Vishal .B. Joshi
Regional Sales Manager -Professional Audio/Video
Ph: 09384608113
Email: vishal_joshi@adityagroup.com
Aditya Infotech Ltd
 Address – 20, Kothari Road, Nungambakkam, Chennai - 34
 Phone - 91-44-28261996/97
 Website: www.adityagroup.com

=====

- Show quoted text -

sb

from Vishal Joshi <vishal_joshi@adityagroup.com>

[hide detail](#)

to Works kalakshetra <works@kalakshetra.in>
cc Dhruv Datta <dhruv_datta@adityagroup.com>
date Mon, Jan 18, 2010 at 11:42 AM
subject Re: supply order-pending materials - reg
mailed-by eigbox.net

Dear Sir,

Greetings from Aditya Infotech!

The EAW Shipment without → There has been some delay from EAW on the shipment due to production issues. We are expected to receive :
between 20th-25th of February 2010. You can expect to get the complete shipment at your premises by 1st of March 2010
fail.

Kindly bear with us due to the inconvenience caused.

Thanks & Regards,

=====

Vishal .B. Joshi
Regional Sales Manager -Professional Audio/Video
Ph: 09384608113
Email: vishal_joshi@adityagroup.com
Aditya Infotech Ltd
Address – 20, Kothari Road, Nungambakkam, Chennai - 34
Phone - 91-44-28261996/97
Website: www.adityagroup.com

=====

On 07-Jan-2010, at 4:48 PM, Works kalakshetra wrote:

- Show quoted text -

57

C:\ 2009-2010\V.Admin\2. Engineering\i.Plan\d.Sound systems\koothambalam.doc	January 18, 2010
--	------------------

Sub: Up gradation of Sound system in Koothambalam – supply of EAW and Audix Products – Extension of time - requested – Reg.

Ref: Work committee approval dated 6.11.2009 - P 02
M/s. Aditya InfoTech letter dated 07.11.2009. - P 15
Revised letter from M/s.Aditya Info tech dated 7.11.2009 P20
Approval note dated 7.11.2009 - P 16

Email from the supplier M/s.Aditya Info tech 18.1.10 -P 34

The supplying of EAW and Audix products was placed on M/s.Aditya info tech , based on the approval by the Works Committee as recommended by the consultant M/s.Sound wizard.

One shipment equipment as part of the supply order was delivered by the M/s.Aditya InfoTech at a total cost of Rs.36,98,944/- as against total supply order of value of Rs.61,70,870/-

As per the terms, the supply order should be completed by 20.10.2010 in all respects. Further the status of the supplier was clarified by email. The supplier had sent the email that they needed 3 months to effect the balance materials till **01.03.2010 without fail.**

Forwarded the same to M/s.Sound wizard, for their comments.

Submitted for approval for giving the extension of time till 01.03.2010 to M/s.Aditya Info Tech.

[Handwritten signature]
EO
[Handwritten signature]
AO
19/1/10
[Handwritten initials]

[Handwritten signature]
CAO
19/01/10

[Handwritten signature]
19/1
DIRECTOR

[Handwritten initials]

Microphones previous option						
Quote from Aditya Infotech	Brand	Qty	Model	Specifications	Rate	Price
Gooseneck	Audix	3	Micropod 18HC	M1250 with Flexible gooseneck 18"	Rs.22,125	Rs.66,375
HandHeld Transmitter with Mic	Audix	4	W3-OM5	RAD-360 System with OM5 dynamic transmitter	Rs.44,000	Rs.1,76,000
BodyPack System	Audix	4	W3-BP	RAD-360 Bodypack System with transmitter	Rs.35,750	Rs.1,43,000
MiniMic Headworn	Audix	4	HT5-BG	Slim-line headset vocal condenser	Rs.16,875	Rs.67,500
Lavalier	Audix	4	ADX10	Miniaturized lavalier condenser	Rs.10,875	Rs.43,500
BodyPack System (accessory)	Audix	4	W3-BP	To use HT5 or ADX10 wired	Rs.35,750	Rs.1,43,000
Lavalier Accessories	Audix	4	APS-911	Windscreen	Rs.950	Rs.3,800
Lavalier Accessories	Audix	4	WS10S	Metal Clip	Rs.1,045	Rs.4,180
Lavalier Accessories	Audix	4	MC10L	Battery/Phantom power adapter	Rs.3,750	Rs.15,000
Microphones updated version						
Quote from E&E Systems India	Brand	Qty	Model	Specifications	Rate	Price
Gooseneck	Sennheiser	3	MZH 3040	40 cm	Rs.10,000	Rs.30,000
Capsule	Sennheiser	3	ME 34	Cardiod for gooseneck	Rs.7,900	Rs.23,700
Table Stand	Sennheiser	3	MZTX 31	Without Switch	Rs.9,550	Rs.28,650
Windscreen	Sennheiser	3	MZW 36 Pro	For gooseneck	Rs.2,899	Rs.8,697
HandHeld Transmitter with Mic	Sennheiser	3	EW 100-835 G3	Handheld Set	Rs.41,000	Rs.1,23,000
MiniMic Headworn	Sennheiser	6	HSP4	Slim-line headset vocal condenser	Rs.35,500	Rs.2,13,000
Lavalier	Sennheiser	6	Ew 122 G3	Miniaturized lavalier condenser	Rs.41,000	Rs.2,46,000

Speaker system (balance) - previous option						
Quote from Aditya Infotech	Brand	Qty	Model	Specifications	Rate	Price
Line Array (H:47/1.20m W:24"/0.60m)	EAW	2	NTL720	500W/500W/500W	Rs.3,35,750	Rs.6,71,500
Flying Cables	EAW	2	KF750	For Subs	Rs.15,250	Rs.30,500
Front Fill Speaker	EAW	4	UB52	150W/8Q	Rs.64,750	Rs.2,59,000
Speakers down + balcony	EAW	20	VR61	300W/8Q	Rs.26,750	Rs.5,35,000
Amplifiers	EAW	6	CAZ1400	450W/4Q	Rs.34,000	Rs.2,04,000
Speaker system (balance) - updated option						
Quote from Sennheiser India	Brand	Qty	Model	Specifications	Rate	Price
Line Array (H:47/1.20m W:24"/0.60m)	EAW	2	NTL720	500W/500W/500W	Rs.3,35,750	Rs.6,71,500
Flying Cables	EAW	2	KF750	For Subs	Rs.16,470	Rs.32,940
Front Fill Speaker	EAW	2	UB82	150W/8Q	Rs.99,360	Rs.1,98,720
Speakers down + balcony	EAW	20	VR61	300W/8Q	Rs.28,890	Rs.5,77,800
Amplifiers	Mackie	6	CAZ1400	450W/4Q	Rs.38,727	Rs.2,32,362

139

Change of supplier required - urgent

Inbox X

from **Didier** <didier@soundwizard.net> [hide details](#) Feb 8 (3 days ago) [Reply](#)

to "Leela Samson ."
 <leelasamson@kalakshetra.in>,
 "Kalakshetra - Srinivasan ."
 <works@kalakshetra.in>
 cc "Leela Samson ."
 <leelasamson@gmail.com>,
 "-Kumbha SW ."
 <kumbha@soundwizard.net>,
 "-Fabien ." <fabien@soundwizard.net>

date Mon, Feb 8, 2010 at 3:25 PM

subject Change of supplier required - urgent

Dear Leela,

We had a busy and tough time lately: one of the main supplier (Aditya Infotech) has not been clear on the supply timeline of 2 remaining batch of items:

- 1/ The full microphone line, to complement the one already purchased a year ago.
- 2/ All balance items for the speaker system (main, monitoring, surrounds)

We tried to get shipping lists, custom papers, etc... we even recently contacted the factories: Most of the pending items had not been sent to India yet.

We understood that for all EAW products (speaker system) the network had been changed in India. After detailed enquiries it seems for the best, with a very strong presence and a new support team and big service center.

SPEAKERS:

So, we suggest this order to be shifted from Aditya Infotech to the new channel, namely E&E Systems India. We can take the opportunity to slightly reshuffle front field speakers with new models that give more coverage and more power with less items, within the same budget. So we could replace the 4 small front fields by 2 new bigger/better ones, that still fit embedded within the stage front steps.

MICROPHONES:

Considering the lack of communication with Aditya Infotech we would like not to take a chance on further delays, and we prefer switching the whole microphone order to another very good brand that is Sennheiser (from Germany). We can also get all items within the same budget with a slight update on models.

So budget would be almost identical, as well as specifications. But time-line restarts from scratch that is 4 to 6 weeks from the date of your green light. The main difference is that these channels will be more reliable for the present delivery and for the future support.

Attached is a list with previous supplier / new supplier items.
 Waiting for your feedback,

Warm Regards,

Didier

Sound Wizard
 Acoustics & Pro-audio

Shakti #9
 Auroville 605 101
 Tamil Nadu, India
 Phone (0) 413 262 26 59
 Phone (0) 413 262 24 80
 Phone (0) 413 262 24 82
 Fax (0) 413 262 34 10

<http://www.soundwizard.net>

(AO)

Pl apprise PIR.

Caladiff
 DIRECTOR

-2-

Approval Obtained / brand, to be supplied value	Change of the supplier and Brand and value as suggested	Difference
EAW products Microphone--- Rs.6,88,849	E & E Systems India Micro phone --- Rs. 6,73,047	
Speaker system Balance items --Rs.19,12,500	Speaker system Sennheiser/India Rs.19,27,487	
Total Rs. 26,01,349		
5%discount 1,30,068		
Total 24,71,281	26,00,534	+1,29,253

Submitted for approval of change of the supplier to M/s.E & E Systems India for Microphone for the value of Rs.6, 73,047/- and M/s.Sennheiser /India for Speaker systems for Rs.19, 27,487/- please.

DIRECTOR

P.T.KRISHNAN

Draft for approval.



J. Ramachandra
for AO 16/12/10



CAO 16/12/10

Cela Samosa
DIRECTOR.

(41)



C:\ 2009-2010\V.Admin\2. Engineering\i.Plan\Sound equipments .doc	February 15, 2010
---	-------------------

Sub: Note – Koothambalam – Sound equipments - EAW and Audix products
– Change of suppliers – Approval of - Reg.

Ref: Approval dated 6.11.2009 (placed below please) - **Annexure I**

In continuation of the above approval note, the supply order for supplying of EAW and Audix products was awarded to M/s.Aditya Info Tech /Chennai at a total cost of Rs.61, 70,870/- Nett. - **Annexure II**

The part of the shipment and equipment was supplied by the agency on 25.11.2009 for a value of Rs.36, 98,944/-. The payment was made to the supplier after the inspection / checking, approved and recommended for payment by the consultant M/s.Sound Wizard. **Annexure III**

Balance material (Rs.24, 71,926) supply as per the supply order has not been delivered by the supplier in spite of remainders from us. As per the supply order the materials should have been delivered by supplier before 31.12.2009, but on the request from him the extension of time was granted to him till 01.03.2010. **Annexure IV**

Meanwhile, the consultant M/s.Sound wizard has sent the request to change of the supplier for remaining supply of sound equipments and recommended the following suppliers and details with justification given – copy is enclosed **Annexure V**

(42)

.....2

To

Sri P. T. KRISHNAN,
No. 1, Wallace Garden, 2nd Street,
CHENNAI - 600 096.

(23)

PTK

ARCHITECTS

1, Second Street, Wallace Garden, Chennai 600 006, India
Phone: (044) 2833 2588, 2833 1759 Fax: (044) 2833 1878

To
Spole 16 Rabbits on 18/2
The bill amount for
1. Termination of contract with EPO
2. Fresh quotes for new system.
D
18/2

(44)

42

Sound Wizard
Pro Audio Acoustic Design

Shakti Area 9
Auroville 605 101 (Via Pondicherry)
Tamil Nadu, India
Phone (0) 413 262 26 59
Phone (0) 413 262 24 80

www.soundwizard.net

45

43

Letter for Aditya Infotech Inbox X

Fabien to me, Didier, -Kumbha, Leela [show details](#) 3:25 PM (1 hour ago) [Reply](#)

Dear Srinivasan,

As requested by you here is the letter you can send to Aditya Infotech:

To: Aditya infotech...
XXX XX
XXXX

Date: XXXX ---X X

Dear Mr. Dhruv Datta,

Following our PO dated: XXX -XXX- xXX you have deliver some of the good as listed. We Thank you for this delivery.

Delivered and paid:

- EAW NTL720 Line Array x 8
- EAW NTS22 Subwoofer x 2
- EAW FB172 Fly Bar for NTL720 x 2

Remaining:

- EAW KF750 Cables x 2
- EAW UB52i Loudspeaker x 4
- EAW VR61 Front Fill Speaker x 20
- EAW CAZ1400 Amplifier x 6
- Audix Micropod 18HC Gooseneck Microphone x 3
- Audix W3-OM5 Handheld Transmitter with Mic x 4
- Audix W3-BP Body Pack System x 4
- Audix HT5-BG Slim Line Headphones Microphone x 4
- Audix ADX10-P Lavalier Mirophone x 4
- Audix W3-BP Body Pack System x 4
- Audix APS-911 Battery / Phantom Power Adapter x 4
- Audix WS10S External Wind Screen x 4
- Audix MC10L Metal Clip x 4

Due to uncertainty in delivery schedule and the changing of your status as the official distributor in for the Indian market we must cancel all pending deliveries under the above motioned PO. All balance equipment under the above mentioned PO are to be canceled with immediate effect.

We, the Kalakshetra Foundation hereby ask you to acknowledge the cancelation of balance item on this mentioned PO. Kindly reply with your acknowledgement of this cancelation.

Thank you for your understanding and cooperation on this matter.

Sincerely,

Please, fill up the XXX parts.

Best regards,

Fabien

(46)

Email: shyam@enesystemsindia.com
Website: www.enesystemsindia.com

44



image001.jpg
2K View Download

47

188

4/5

Fwd: Sub : Supply order Ref : Your offer No. PI.No: 44/DV-D01U/05.12.201

0 Inbox X

from **info kalakshetra** [hide details](#) 12:31 PM (3 minutes ago) [Reply](#)

<info@kalakshetra.in>
to works@kalakshetra.in
date Mon, Feb 22, 2010 at 12:31 PM
subject Fwd: Sub : Supply order
Ref : Your offer No. PI.No:
44/DV-D01U/05.12.2010

----- Forwarded message -----

From: **Shyam Suresh** <shyam@enesystemsindia.com>
Date: Feb 5, 2010 12:19 PM
Subject: Sub : Supply order Ref : Your offer No. PI.No: 44/DV-D01U/05.12.2010
To: info@kalakshetra.in
Cc: "S.Gopinadhan" <poncho@enesystemsindia.com>, roshan <roshan@enesystemsindia.com>

Date:05/02/2010

To,
Kalakshetra Foundation
Thiruvanmiyur , Chennai -600041.
Tel : 044-24520836 / 4057.
Fax: 044-24524359.
E Mail: info@kalakshetra.in

Sub : Supply order
Ref : Your offer No. PI.No: 44/DV-D01U/05.12.2010

As per your letter we accept all the conditions .

Please clarify if the Freight charges will be paid by you along with the final settlement.

The material is available in stock and subject to your approval can be sent on Monday.

Looking forward to hear from you.

Thanks & Regards,

Shyam Suresh

Sales / Project Engineer



E&E SYSTEMS (INDIA) PVT LTD
#14, Bhattrahalli Old Madras Road
KR Puram Bangalore - 560049, India

Phone: +91 (0) 80 41903270
Fax: +91 (0) 41903005
Direct: +91 (0) 80 41903879
Mobile: +91 9590207705

(48)

4.	EAW VR61 Front Fill Speaker	20
5.	EAW CAZ 1400 Amplifier	6
6.	Audix Micro pod 18HC Gooseneck Microphone	3
7.	Audix W3-OM5 Handheld Transmitter with Mic	4
8.	Audix W3-BP Body Pack System	4
9.	Audix HT5-BG Slim Line Headphone Microphone	4
10.	Audix ADX 10-P Lavalier Microphone	4
11.	Audix W3-BP Body Pack System	4
12.	Audix APS-911 Battery Phantom Power Adapter	4
13.	Audix WS10S External Wind Screen	4
14.	Audix MC 10L Metal Clip	4

Based on the recommendation given by ^{our} the consultant M/s.Sound Wizard, all the materials should be delivered in all respects by 20.12.2009 as per the supply order and delivered only part materials.

Due to uncertainty in delivery schedule and the changing of your status as the official distributor in for the Indian market we must cancel all pending deliveries of materials under the above mentioned supply order . All the balance equipment under the above mentioned supply order is to be terminated with immediate effect.

Kindly acknowledge ^{receipt of the this letter of confirmation termination} the termination of the pending materials of supply order cited above and ^{reply.} of balance equipment.

Leela Samson
Director

[Handwritten signature]

①
20/12/10
AO

(mhuu)
CAO

Leela Samson
DIRECTOR 22/2

④

DRAFT

C:\2009-2010\V.Admin\2. Engineering\i.Plan\d.Sound systems\koothambalam.doc	February 20, 2010
---	-------------------

M/s.Aditya InfoTech Limited,
No, 20 Kothari Road,
Nungambakkam,
Chennai 600 034.

Sir(s)

Sub: Supply of EAW & Audix Products – **Termination of Supply order** - Reg

Ref: Your offer No. AIL / CHN / 1409 /001 dated 14.09.2009
Your letter dated 07.11.2009
Your letter dated 10.11.2009

Our supply order No. C\2009-2010\V.Admin\2.Engineering\i.Plan\d.Sound systems
\koothambalam.doc dated 09 November 2009.

Recommendation from the consultant M/s.Sound Wizard

Following our supply order cited above, you have delivered some of the goods as listed. We thank you for ~~this delivery~~ *delivered of the same*

Delivered and paid:

Sl. No.	Unit	Qty.
1	EAW NTL 720 Line Array	8
2.	EAW NTS22 Subwoofer	2
3.	EAW FB172 Fly Bar for NTL 720	2

~~2.57.02~~
Box (3) (10)
Box (1) (2)
Box (11) (12)

Remaining as per the supply order:

Sl. No.	Unit	Qty.
1	EAW NTL 720 Line Array	2
2.	EAW KF 750 Cables - FC700C	2
3.	EAW UB52i Loudspeaker	4

(50)

4.	EAW VR61 Front Fill Speaker	20
5.	EAW CAZ 1400 Amplifier	6
6.	Audix Micro pod 18HC Gooseneck Microphone	3
7.	Audix W3-OM5 Handheld Transmitter with Mic	4
8.	Audix W3-BP Body Pack System	4
9.	Audix HT5-BG Slim Line Headphone Microphone	4
10.	Audix ADX 10-P Lavalier Microphone	4
11.	Audix W3-BP Body Pack System	4
12.	Audix APS-911 Battery Phantom Power Adapter	4
13.	Audix WS10S External Wind Screen	4
14.	Audix MC 10L Metal Clip	4

Based on the recommendation given by our consultant M/s.Sound Wizard, all the materials should be delivered in all respects by 20.12.2009 as per the supply order and delivered only part materials.

Due to uncertainty in delivery schedule and the changing of your status as the official distributor in for the Indian market we must cancel all pending deliveries of materials under the above mentioned supply order . All the balance equipment under the above mentioned supply order is to be terminated with immediate effect.

Kindly acknowledge the receipt of the letter and confirm termination of the balance equipment.



Leela Samson
Director



ofc -
RPAD

C:\2009-2010\V.Admin\2. Engineering\i.Plan\d.Sound systems\koothambalam.doc	February 20, 2010
---	-------------------

M/s.Aditya InfoTech Limited,
No, 20 Kothari Road,
Nungambakkam,
Chennai 600 034.

Sir(s)

Sub: Supply of EAW & Audix Products – **Termination of Supply order** - Reg

Ref: Your offer No. AIL / CHN / 1409 /001 dated 14.09.2009
Your letter dated 07.11.2009
Your letter dated 10.11.2009

Our supply order No. C\2009-2010\V.Admin\2.Engineering\i.Plan\d.Sound systems \koothambalam.doc dated 09 November 2009.

Recommendation from the consultant M/s.Sound Wizard

Following our supply order cited above, you have delivered some of the goods as listed. We thank you for this delivery.

Delivered and paid:

Sl. No.	Unit	Qty. in Nos
1	EAW NTL 720 Line Array	8
2.	EAW NTS22 Subwoofer	2
3.	EAW FB172 Fly Bar for NTL 720	2

Remaining as per the supply order:

Sl. No.	Unit	Qty. in Nos
1	EAW NTL 720 Line Array	2
2.	EAW KF 750 Cables - FC700C	2
3.	EAW UB521 Loudspeaker	4

(52)

Sennheiser proposal for microphones

Inbox X

Reply

from **Naveen.Sridhar@sennheiserindia.com** [hide details](#) 1:51 PM (20 hours ago)
to works@kalakshetra.in
date Wed, Feb 24, 2010 at 1:51 PM
subject Sennheiser proposal for microphones

Dear Mr.Srinivasan,

Thank you for your interest in Sennheiser microphones for the auditorium project.I have attached the proposal for your reference.

We look forward to your PO in serving to the best of our ability at all times.

Thanks & regards

Naveen Sridhar

Sales Manager-Professional segment



+91-9886777132

2 attachments — [Download all attachments](#)



noname
2K [View](#) [Download](#)

Kalakshetra

59

Microphones previous option						
Quote from Aditya Infotech	Brand	Qty	Model	Specifications	Rate	Price
Gooseneck	Audix	3	Micropod 18HC	M1250 with Flexible gooseneck 18"	Rs.22,125	Rs.66,375
HandHeld Transmitter with Mic	Audix	4	W3-OM5	RAD-360 System with OM5 dynamic transmitter	Rs.44,000	Rs.1,76,000
BodyPack System	Audix	4	W3-BP	RAD-360 Bodypack System with transmitter	Rs.35,750	Rs.1,43,000
MiniMic Headworn	Audix	4	HT5-BG	Slim-line headset vocal condenser	Rs.16,875	Rs.67,500
Lavalier	Audix	4	ADX10	Miniaturized lavalier condenser	Rs.10,875	Rs.43,500
BodyPack System (accessory)	Audix	4	W3-BP	To use HT5 or ADX10 wired	Rs.35,750	Rs.1,43,000
Lavalier Accessories	Audix	4	APS-911	Windscreen	Rs.950	Rs.3,800
Lavalier Accessories	Audix	4	WS10S	Metal Clip	Rs.1,045	Rs.4,180
Lavalier Accessories	Audix	4	MC10L	Battery/Phantom power adapter	Rs.3,750	Rs.15,000
Microphones updated version						
Quote from Sennheiser India	Brand	Qty	Model	Specifications	Rate	Price
Gooseneck	Sennheiser	3	MZH 3040	40 cm	Rs.10,000	Rs.30,000
Capsule	Sennheiser	3	ME 34	Cardiod for gooseneck	Rs.7,900	Rs.23,700
Table Stand	Sennheiser	3	MZTX 31	Without Switch	Rs.9,550	Rs.28,650
Windscreen	Sennheiser	3	MZW 36 Pro	For gooseneck	Rs.2,899	Rs.8,697
HandHeld Transmitter with Mic	Sennheiser	3	EW 100-835 G3	Handheld Set	Rs.41,000	Rs.1,23,000
MiniMic Headworn	Sennheiser	6	HSP4	Slim-line headset vocal condenser	Rs.35,500	Rs.2,13,000
Lavalier	Sennheiser	6	Ew 122 G3	Miniaturized lavalier condenser	Rs.41,000	Rs.2,46,000

Speaker system (balance) - previous option						
Quote from Aditya Infotech	Brand	Qty	Model	Specifications	Rate	Price
Line Array (H:47/1.20m W:24"/0.60m)	EAW	2	NTL720	500W/500W/500W	Rs.3,35,750	Rs.6,71,500
Flying Cables	EAW	2	KF750	For Subs	Rs.15,250	Rs.30,500
Front Fill Speaker	EAW	4	UB52	150W/8Ω	Rs.64,750	Rs.2,59,000
Speakers down + balcony	EAW	20	VR61	300W/8Ω	Rs.26,750	Rs.5,35,000
Amplifiers	EAW	6	CAZ1400	450W/4Ω	Rs.34,000	Rs.2,04,000

Speaker system (balance) - updated option						
Quote from E&E Systems India	Brand	Qty	Model	Specifications	Rate	Price
Line Array (H:47/1.20m W:24"/0.60m)	EAW	2	NTL720	500W/500W/500W	Rs.3,35,750	Rs.6,71,500
Flying Cables	EAW	2	KF750	For Subs	Rs.16,470	Rs.32,940
Front Fill Speaker	EAW	2	UB82	150W/8Ω	Rs.99,360	Rs.1,98,720
Speakers down + balcony	EAW	20	VR61	300W/8Ω	Rs.28,890	Rs.5,77,800
Amplifiers	Mackie	6	CAZ1400	450W/4Ω	Rs.38,727	Rs.2,32,362

55

CSB/110
AO

[Handwritten signature]

CAO

DIRECTOR

Change of supplier required - urgent Inbox X

Didier Dear Leela, We had a busy and tough time lately: one of the main supplier (Feb 8

Works kalakshetra Dear sir, It is learned from attached file state 5:46 PM (17 hours ago)

from **Didier** hide details 10:30 AM (28 minutes ago) [Reply](#)

<didier@soundwizard.net>
 to Works kalakshetra
 <works@kalakshetra.in>
 cc "-Fabien ."
 <fabien@soundwizard.net>,
 "-Kumbha SW ."
 <kumbha@soundwizard.net>
 date Fri, Mar 5, 2010 at 10:30 AM
 subject Re: Change of supplier
 required - urgent

Dear Sir,

We deeply apologize for the mistake that came from our end.

Here attached is an updated list, that we send today itself stamped and signed at your address.
 I will today follow-up the multiple quote process and revert to you with the final status.

Warm Regards,

Didier
 - Show quoted text -

Sound Wizard
Acoustics & Pro-audio

Shakti #9
Auroville 605 101
Tamil Nadu, India
Phone (0) 413 262 26 59
Phone (0) 413 262 24 80
Phone (0) 413 262 24 82
Fax (0) 413 262 34 10

<http://www.soundwizard.net>

 **10-03-05 D Aditya Vs E&E.pdf**
 29K [View](#) [Download](#)

[Reply](#)

[Reply to all](#)

[Forward](#)

(Handwritten signature)

(Handwritten initials: AS/10 AO)

CAO

(Handwritten signature: Cular)
 DIRECTOR *(Handwritten initials: S/2)*

(Handwritten circled initials: Eb)

Change of supplier required - urgent Inbox X

Didier Dear Leela, We had a busy and tough time lately: one of the main supplier (Feb 8

Works kalakshetra to Didier [show details](#) 5:46 PM (17 hours ago) [Reply](#)

Dear sir,

It is learned from attached file statement that

Microphones supply order may be placed to M/s.E& E Systems at a total cost of Rs.6,73,047.

Speaker system (balance) updated version supply order may be placed to M/s.Sennheiser India at a cost of Rs.19,27,487/-

But, based on the quote received from M/s.Sennheiser and their value for supply of microphones is Rs. 6,73,047/-

and quote received from M/s.E & E systems for supplying of speaker system (balance) updated version is Rs.19,27,488/-

It is actually vice-versa

please clarify and sent the corrected one in soft and hard copy to us for enabling the process immediately

for supply of microphones, we have received three quotes - from Sennhieser -soft copy/we need hard copy which is not received sofar from them for process.

others from m/s.Sasi enterprises and M/s.telrad

for supply of speaker system (balance) upadated version, we received quote from M/s.E&E system Bangalore.

Further we need two more quote from supplier for processing for approval please. May be asked to sent to this office as soon as possible

As per the advise, the termination of contract./supply of materials(balance) from the supply order issued to M/s.Aditya infotech was issued to the agency and acknowledgement (RPAD) received.

Warm regards

V.Srinivasan
Kalakshetra
- Show quoted text -

CAO

Leela
DIRECTOR 5/3

Microphones previous option						
Quote from Aditya Infotech						
Brand	Qty	Model	Specifications	Rate	Price	Total Incl. Tax
Gooseneck	3	Micropod 18HC	M1250 with Flexible gooseneck 18"	Rs.22,125	Rs.66,375	Rs.6,88,849
HandHeld Transmitter with Mic	4	W3-OM5	RAD-360 System with OM5 dynamic transmitter	Rs.44,000	Rs.1,76,000	
BodyPack System	4	W3-BP	RAD-360 Bodypack System with transmitter	Rs.35,750	Rs.1,43,000	
MiniMic Headworn	4	HT5-BG	Slim-line headset vocal condenser	Rs.16,875	Rs.67,500	
Lavalier	4	ADX10	Miniaturized lavalier condenser	Rs.10,875	Rs.43,500	
BodyPack System (accessory)	4	W3-BP	To use HT5 or ADX10 wired	Rs.35,750	Rs.1,43,000	
Lavalier Accessories	4	APS-911	Windscreen	Rs.950	Rs.3,800	
Lavalier Accessories	4	WS10S	Metal Clip	Rs.1,045	Rs.4,180	
Lavalier Accessories	4	MC10L	Battery/Phantom power adapter	Rs.3,750	Rs.15,000	

Microphones updated version						
Quote from Sennheiser India						
Brand	Qty	Model	Specifications	Rate	Price	Total Incl. Tax
Gooseneck	3	MZH 3040	40 cm	Rs.10,000	Rs.30,000	Rs.6,73,047
Capsule	3	ME 34	Cardiod for gooseneck	Rs.7,900	Rs.23,700	
Table Stand	3	MZTX 31	Without Switch	Rs.9,550	Rs.28,650	
Windscreen	3	MZW 36 Pro	For gooseneck	Rs.2,899	Rs.8,697	
HandHeld Transmitter with Mic	3	EW 100-835 G3	Handheld Set	Rs.41,000	Rs.1,23,000	
MiniMic Headworn	6	HSP4	Slim-line headset vocal condenser	Rs.35,500	Rs.2,13,000	
Lavalier	6	Ew 122 G3	Miniaturized lavalier condenser	Rs.41,000	Rs.2,46,000	

Speaker system (balance) - previous option						
Quote from Aditya Infotech						
Brand	Qty	Model	Specifications	Rate	Price	Total Incl. Tax
Line Array (H:47/1.20m W:24"/0.60m)	2	NTL720	500W/500W/500W	Rs.3,35,750	Rs.6,71,500	Rs.19,12,500
Flying Cables	2	KF750	For Subs	Rs.15,250	Rs.30,500	
Front Fill Speaker	4	UB52	150W/8Ω	Rs.64,750	Rs.2,59,000	
Speakers down + balcony	20	VR61	300W/8Ω	Rs.26,750	Rs.5,35,000	
Amplifiers	6	CAZ1400	450W/4Ω	Rs.34,000	Rs.2,04,000	

Speaker system (balance) - updated option						
Quote from E&E Systems India						
Brand	Qty	Model	Specifications	Rate	Price	Total Incl. Tax
Line Array (H:47/1.20m W:24"/0.60m)	2	NTL720	500W/500W/500W	Rs.3,35,750	Rs.6,71,500	Rs.19,27,487
Flying Cables	2	KF750	For Subs	Rs.16,470	Rs.32,940	
Front Fill Speaker	2	UB82	150W/8Ω	Rs.99,360	Rs.1,98,720	
Speakers down + balcony	20	VR61	300W/8Ω	Rs.28,890	Rs.5,77,800	
Amplifiers	6	CAZ1400	450W/4Ω	Rs.38,727	Rs.2,32,362	

558

For SOUND WIZARD
[Signature]
Executive

SOUND WIZARD
Audio Design and Consultancy

77200
5

SOUND WIZARD
Shakti-Auroville 605 101
Tamil Nadu-India
Tel : 0413 2622659 Fax : 0413 2623410
Email : soundwiz@auroville.org.in
Website : www.soundwizard.net

Kind Atten Mr. Srinivasan,

TO:

M/S: Kalakshetra Foundation
Rukmani Devi College of Fine Arts/
Kalakshetra Road / Thiruvanniyur /
Chennai - 600 041

PH : (44) 24 52 11 69
cell : 98 407 62 646

5/

59

57

SOUND WIZARD also approved the difference of old supplier, specification /brand and change of supplier name and offer value as per the information below:

Approval /obtained/brand to be supplied value	Change of the supplier and Brand and value as suggested	Difference
Aditya Infotech Microphone--Rs.6,88,849 5%discount 34,442 - 6,54,407	M/s.Sennheiser/India Microphone Rs. 6, 73,047	(+)18,640
Aditya Infotech Balance items -Rs.19,12,500 5% Discount - 95,625 - 18,16,875	M/s.E & E Systems India Speaker systemRs.19,27,487	(+)1,10,612
Total 24,71,282	26,00,534	(+) 1,29,252

For SOUND WIZARD

Didier Weiss

60

SOUND WIZARD – Acoustics and Pro-Audio

Shakti, Auroville - 605 101, Tamil Nadu, India / Tel: +91 (0) 413 262 26 59 Fax: 262 34 10

Email: info@soundwizard.net Web site: www.soundwizard.net



REPORT dated 9/03/2010

To: Kalakshetra Foundation

Re: Supplier final recommendation for your auditorium equipment balance purchase

Pages: 2

For supplying of microphones (balance) updated version

Sl.No.	Name of the suppliers	Quoted value	Position	Total cost to be awarded-L1
1	M/s.Sennheiser India Pvt Ltd	Rs.6,73,047/-	L 1	Rs.6,73,047/
2	M/s.Sasi Enterprises	Rs7,34,966/-	L 2	
3	M/s.Telerad	Rs.7,20,967/-	L 3	

SOUND WIZARD approved and recommended the M/s.Senheiser India Pvt ltd, brand and specification and requested to place the supply order on them, at a total cost of Rs.6, 73,047/-

For supplying of speaker (balance) updated version:

Sl.No.	Name of the suppliers	Quoted value	Position	Total cost to be awarded-L1
1	M/s.E & E systems /Bangalore	Rs.19,27,488/-	L 1	Rs.19,27,488/ Freight and Insurance will be additional at actual.
2	M/s.MRH Digital systems pvt ltd, Mumbai	Rs20,23,878-	L 2	
3	M/s.Resonaltors Bangalore	Rs22,00,019/-	L 3	

SOUND WIZARD approved and recommended the M/s.E& E systems /Bangalore, brand and specification and requested to place the supply order on them, at a total cost of Rs.19,27,488/-

SOUND WIZARD – Acoustics and Pro-Audio

Shakti, Auroville - 605 101, Tamil Nadu, India / Tel: +91 (0) 413 262 26 59 Fax: 262 34 10

Email: info@soundwizard.net Web site: www.soundwizard.net

(b)

change of suppliers - recommendation letter reg. Inbox X

Works kalakshetra Sir, All the quote are received and process for app; Mar 6 (3 days ago)

Works kalakshetra Dear sir, I am enclosing the details of the quc 4:50 PM (23 hours ago)

from **Didier** <didier@soundwizard.net> [hide details](#) 3:12 PM (1 hour ago) [Reply](#)
to Works kalakshetra
<works@kalakshetra.in>
cc "-Kumbha SW."
<kumbha@soundwizard.net>,
"-Fabien."
<fabien@soundwizard.net>,
"Leela Samson."
<leelasamson@kalakshetra.in>
date Tue, Mar 9, 2010 at 3:12 PM
subject Re: change of suppliers -
recommendation letter reg.

Dear Sir,

Kindly find attached the requested document. A printed and signed copy will be couriered to you today itself.

Kindly revert to confirm reception of this Email

All the best,

Didier

for the above comparative statment and placing the supply order needed your justification and recommendation for processing approval.

Kindly sent the justification and recommendation through email and followed by Hard copy to this office at the earliest.

warm regards

V.Srinivasan
Kalakshetra

Sound Wizard
Acoustics & Pro-audio

Shakti #9
Auroville 605 101
Tamil Nadu, India
Phone (0) 413 262 26 59
Phone (0) 413 262 24 80
Phone (0) 413 262 24 82
Fax (0) 413 262 34 10

<http://www.soundwizard.net>

(62)

Kind Attn: Mr. ~~XXXXXXXXXX~~

~~XXXXXXXXXX~~

9

COE / 3/8
20/1/8

(59)

774

To,
Mrs. Kalakshetra Foundation,
Rukmani Devi College of Fine Arts,
Kalakshetra Road, Thiruvananthapuram,
Chennai - 600041.



SASI ENTERPRISES

If Undelivered Please Return to :

"Nelson Plaza", New No. 90, (149), Nelson Manickam Road,
Choolaimedu, Chennai - 600 094.
Telefax : 91-44-23746661, 23746761, 2374376
E-mail : dhayalvr@vsnl.com / sasient@bsnl.in



Authorised System Integrator

BOSCH SECURITY & COMMUNICATION SYSTEM

AUTHORISED : BOSCH SYSTEM INTEGRATOR FOR COMMUNICATION, CX
FIRE ALARM, ACCESS CONTROL SYSTEMS & TELEX COMMUNICATION



SENNHEISER MICROPHONES & CIRCUITRY PROF



Sasi Enterprises

"Nelson Plaza", New No.90, (149), Nelson Manickam Road, Choolaimedu, Chennai - 600 094.
Telefax : 91-44-23746661, 23746761, 23743769
E-mail : dhayalvr@vsnl.com/ dhayalvr@eth.net



AUTHORISED : BOSCH SYSTEM INTEGRATOR FOR COMMUNICATION, CCTV, FIRE ALARAM,
ACCESS CONTROL SYSTEMS & TELEX COMMUNICATION PRODUCT.

TO
M/s. Kalakshetra Foundation ,
Kalakshetra Road, Thiruvanmiyur,
Chennai - 600 041.
Ph: 24521169, 0836, 4057
Email : works@kalakshetra.in

NO:SE/Q/KF/9661
Dt: 01.03.2010

Kind Attn : Mr. Srinivasan

Dear Sir,

Sub : Offer for Supply of Sennheiser Make Wireless Microphone System for Kalakshetra - Reg.

With reference to the above subject. Accordingly we pleased to submitting our offer details given below

Sl.No.	Type	Description	Qty	U / Rate	Amount
1	MZH 3040	Gooseneck for ME Installed	3	10,500	31,500
2	ME 34	Condenser Mic	3	8,295	24,885
3	MZTX 31	Table Stand	3	10,027	30,081
4	MZW 36 PRO	Windsheild	3	3,044	9,132
5	EW 135 G3	Vocal Set	3	43,050	129,150
6	EW 122 G3	Presentation Set	6	43,050	258,300
7	HSP EW 4	Headset Microphone Black	6	37,275	223,650
Total					706,698

(Rupees Seven Lakhs Six Thousand Six Hundred and Ninety Eight Only)

Our Terms and Conditions:-

Validity : Our offer is valid till 30 Days from date of this Offer.

Prices : Prices quoted by us are Exclusive of VAT @4% will be charged extra.

Delivery : Within 10 days after receipt of your confirmed order.

Payment : 50% Advance payment along with P.O. Balance 50% before delivery of the materials.

Guarantee : Twelve months from date of supply against manufacturing defects only.

Thanking you and assuring you of our best services always.

Yours faithfully,
For SASI ENTERPRISES.

R. BALARAMAN
PROPRIETOR

7,06,698

4% VAT

28,268

7,34,966

69



Resonators

Date:03/03/2010.

CST & Tin No:29840481834.

Proforma Invoice

RefNo :02.03/03/2010

Kind Attn: Ms. Leela Samson
KALAKSHETRA Foundation
Thirruvanmiyur
Chennai 600041.

Your Sales Tax Nos:

Kindly Attend:PO For Veena Varuni Project.

Contact no: +91 9880535569 - 9845135569

SL.NO	PARTICULARS	Qty	Unit Price	Value
01	UB82e Black / The UB82e has a compact vented rectangular enclosure and is engineered to provide very high output and wideband response in distributed applications.	02	106,315	212,630
02	KF750/KF755 Spare Fly Clip/Cables [FC700C]	02	17,623	35,246
03	Mackie FRS 1700 / 1660W Professional Lightweight Stereo Power Amplifier	06	41,825	250,950
04	VR61 Black / The VR61 compact full-range loudspeaker offers a specially engineered, purpose-designed 6-inch LF driver that enables it to match the output of competitive 8-inch 2-way designs.	20	36,912	738,240
05	NTL720 Black 230 VAC / A true three-way design delivering big-time performance with maximized vocal clarity. Next, the entire enclosure face is filled by a full-sized mid/high horn providing 110-degree (horizontal) by 12-degree (vertical) dispersion.	02	359,253	718.506

All payments requested by "Account payee" instruments only

Sub Total: 1,955,572.00
Vat @ 12.5% 244,447.00
Grand Total 2,200,019.00

RESONATORS
905/37, 4th Main, 3rd Cross
Vidyaranyapuram, Mysore-570 008
Karnataka, INDIA
Ph: 0821-2482113, Cell: 98451 35569

(Twenty Two Lakh & Nineteen Only)

For Resonators,

A.P.Srinivas

Terms & Condition :

Payment as 100 % advance DD against Delivery .
Freight and Freight insurance will be additional at actual .
Delivery immediate if in stock or 4 - 8 weeks from the date of Confirmed order along with 50 % advance .
Proforma Invoice is valid for 30 days .

905/37,4th Main, 3rd Cross, Vidydranyapuram, Mysore-570008, Karnataka, INDIA.
Ph : (0821) 2482113 , 2481679. Mobile : 9880535569 , 9845135569.
Email : srinirec@hotmail.com , fluteprasad@rediffmail.com

65

10/15
10/20
10/23

Shankari Digital Recording
Professionals in Audio Digital Recording



7 Hills
Professionals in Sound & Light

Resonators

Date:03/03/2010.

CST & Tin No:29840481834.

Proforma Invoice

Ref No :02.03/03/2010

Kind Attn: Ms. Leela Samson
KALAKSHETRA Foundation
Thirruvanmiyur
Chennai 600041.

Your Sales Tax Nos:

Kindly Attend:PO For Veena Varuni Project.

Contact no: +91 9880535569 - 9845135569

SL.NO	PARTICULARS	Qty	Unit Price	Value
01	UB82e Black / The UB82e has a compact vented rectangular enclosure and is engineered to provide very high output and wideband response in distributed applications.	02	106,315	212,630
02	KF750/KF755 Spare Fly Clip/Cables [FC700C]	02	17,623	35,246
03	Mackie FRS 1700 / 1660W Professional Lightweight Stereo Power Amplifier	06	41,825	250,950
04	VR61 Black / The VR61 compact full-range loudspeaker offers a specially engineered, purpose-designed 6-inch LF driver that enables it to match the output of competitive 8-inch 2-way designs.	20	36,912	738,240
05	NTL720 Black 230 VAC / A true three-way design delivering big-time performance with maximized vocal clarity. Next, the entire enclosure face is filled by a full-sized mid/high horn providing 110-degree (horizontal) by 12-degree (vertical) dispersion.	02	359,253	718.506

All payments requested by "Account payee" instruments only

Sub Total:	1,955,572.00
Vat @ 12.5%	244,447.00
Grand Total	2,200,019.00

RESONATORS
905/37, 4th Main, 3rd Cross
Vidyaranyaapuram, Mysore-570 008
Karnataka, INDIA
Ph: 0821-2482113, Cell: 98451 35569

(Twenty Two Lakh & Nineteen Only)

For Resonators,

A.P.Srinivas

Terms & Condition :

Payment as 100 % advance DD against Delivery .
 Freight and Freight insurance will be additional at actual .
 Delivery immediate if in stock or 4 - 8 weeks from the date of Confirmed order along with 50 % advance .
 Proforma Invoice is valid for 30 days .

905/37,4th Main, 3rd Cross, Vidyaranyaapuram,Mysore-570008,Karnataka,INDIA.
 Ph : (0821) 2482113 , 2481679.Mobile : 9880535569 , 9845135569.
 Email : srinirec@hotmail.com , fluteprasad@rediffmail.com

66

TELERAD

146/8, Second Floor, Millenium Towers,
(Nr. to Mehta Nagar Bus Stop),
Nelson Manickam Road, Chennai - 600 029.
Telefax : 23744883, 23745359 / 60, 43553070
Email : teleradchennai@airtelmail.in
www.teleradindia.com

60
SONY

FINAL OFFER

TO

M/S Kalakshetra foundation,
Chennai.

Authorised Distributer for
Sennheiser Electronics India Pvt. Ltd.,
39-42B, Edmonton Shopping Mall,
Hotel Bristol, M.G. Road, Gurgaon
Haryana - 122 002.

Our Ref. No.: TEL/CHN/212/SENN/O9-10/INR

Dt.:27/02/2010

S.NO.	MODEL	DESCRIPTIONS	QTY	UNIT PRICE IN INR	TOTAL PRICE IN INR
1	MZH 3040	GOOSENECK FOR ME INSTALLED	3	10,300.00	30,900.00
2	ME 34	CONDENSER MIC	3	8,137.00	24,411.00
3	MZTX 31	TABLE STAND	3	9,836.00	29,508.00
4	MZW 36 PRO	WINDSHIELD	3	2,986.00	8,958.00
5	EW 135 G3	VOCAL SET	3	42,230.00	126,690.00
6	EW 122 G3	PRESENTATION SET	6	42,230.00	253,380.00
7	HSP EW 4	HEADSET MICROPHONE BLACK	6	36,565.00	219,390.00
					693,237.00

Terms and Conditions:

- 1 DELIVERY :With in 10days from the date of receipt of your confirmed order.
- 2 PAYMENT :50% Advance and Balance Against delivery
- 3 TAXES :VAT 4 % Will be Extra.
- 4 VALIDITY :1 Month
- 6 ORDER IN FAVOUR OF : M/S TELERAD,CHENNAI.
- 7 WARRANTY :Two Years from the date of Invoice
- 8 BILLING :From TELERAD,CHENNAI.

For TELERAD

T.P. KUMAR
AREA MANAGER



AREA CODE: 079
TIN: 33671463744
C.S.T NO.: 867223/01/04/2006

6,93,237 -

4% VAT. 27,730 -

7,20,967 -

67

Authorised Agents for **SONY** Professional Video Systems

A DIVISION OF AMBALAL SARABHAI ENTERPRISES LTD., REGD. OFFICE : WADI WADI, VADHODHARA - 309 007

SOUND WIZARD also approved the difference of old supplier, specification /brand and change of supplier name and offer value as per the information below:

Approval /obtained/brand to be supplied value	Change of the supplier and Brand and value as suggested	Difference
Aditya Infotech Microphone--Rs.6,88,849 5%discount 34,442 - 6,54,407	M/s.Sennheiser/India Microphone Rs. 6, 73,047	(+)18,640
Aditya Infotech Balance items -Rs.19,12,500 5% Discount - 95,625 - 18,16,875	M/s.E & E Systems India Speaker systemRs.19,27,487	(+)1,10,612
Total 24,71,282	26,00,534	(+) 1,29,252

For SOUND WIZARD
For SOUND WIZARD

Executive
 Didier Weiss

(68)
 10/1

65

Sound Wizard

Acoustics & Pro-audio

REPORT dated 9/03/2010

To: Kalakshetra Foundation

Re: Supplier final recommendation for your auditorium equipment balance purchase

Pages: 2

For supplying of microphones (balance) updated version

Sl.No.	Name of the suppliers	Quoted value	Position	Total cost to be awarded-L1
1	M/s.Sennheiser India Pvt Ltd	Rs.6,73,047/-	L 1	Rs.6,73,047/
2	M/s.Sasi Enterprises	Rs7,34,966/-	L 2	
3	M/s.Telerad	Rs.7,20,967/-	L 3	

SOUND WIZARD approved and recommended the M/s.Senheiser India Pvt Ltd, brand and specification and requested to place the supply order on them, at a total cost of Rs.6, 73,047/-

For supplying of speaker (balance) updated version:

Sl.No.	Name of the suppliers	Quoted value	Position	Total cost to be awarded-L1
1	M/s.E & E systems /Bangalore	Rs.19,27,488/-	L 1	Rs.19,27,488/ Freight and Insurance will be additional at actual.
2	M/s.MRH Digital systems pvt ltd, Mumbai	Rs20,23,878-	L 2	
3	M/s.Resonators Bangalore	Rs22,00,019/-	L 3	

SOUND WIZARD approved and recommended the M/s.E& E systems /Bangalore, brand and specification and requested to place the supply order on them, at a total cost of Rs.19,27,488/-

for SOUND WIZARD

Executive

SOUND WIZARD – Acoustics and Pro-Audio

Shakti, Auroville - 605 101, Tamil Nadu, India / Tel: +91 (0) 413 262 26 59 Fax: 262 34 10
Email: info@soundwizard.net Web site: www.soundwizard.net

(69)



॥ श्रीहरिः ॥

ADITYA INFOTECH LTD.

No. 20, Kothari Road, Nungambakkam, Chennai - 600 034.
Tel : 044- 28261996, 97, 32984914 • E-mail : aditya_chen@adityagroup.com
Website : www.adityagroup.com



Date: 10/03/2010
Place: Chennai

To,
The Director,
Kalakshetra Foundation,
Thiruvamyur,
Chennai - 600 041

Dear Sir/Madam,

This is with reference to your letter dated February 20, 2010 on the Termination Order of EAW and Audix Products for the Koothambalam upgrading project in Chennai.

We have delivered the below mentioned Goods and have received the Full Payment for the same.

S.No	UNIT	Quantity	Price Per Unit (INR)	VAT (%)	Unit Value excluding VAT
1	EAW NTL 720 Line Array	8	335750.00	12.5	2686000.00
2	EAW NTS22 Subwoofer	2	246625.00	12.5	493250.00
3	EAW FB172 Fly Bar for NTL 720	2	140875.00	12.5	281750.00
Total Value Excluding VAT					3461000.00
Discount (5%) (-)					173050.00
VAT - 12.5% (+)					410993.75
Rounded Off Sales					0.25
GRAND TOTAL					3698944.00

The balance goods could not be delivered due to uncertainty in delivery schedule from the manufacturer's and as informed to us by your consultant, M/S Sound Wizard, they did not have the patience to wait for balance delivery any further.

Kindly acknowledge the receipt of this letter.

Hoping to keep this ongoing business relationship in the future.

For Aditya Infotech Limited

Vishal .B. Joshi
Regional Sales Manager- Professional Audio/Video

70

Shankari Digital Recording

Professionals in Audio Digital Recording



7 Hills

Professionals in Sound & Light

Resonators

Date:03/03/2010.

CST & Tin No:29840481834.

Proforma Invoice

Ref No :02.03/03/2010

Kind Attn: Ms. Leela Samson
KALAKSHETRA Foundation
Thirruvanmiyur
Chennai 600041.

Your Sales Tax Nos:

Kindly Attend:PO For Veena Varuni Project.

Contact no: +91 9880535569 - 9845135569

SL.NO	PARTICULARS	Qty	Unit Price	Value
01	UB82e Black / The UB82e has a compact vented rectangular enclosure and is engineered to provide very high output and wideband response in distributed applications.	02	106,315	212,630
02	KF750/KF755 Spare Fly Clip/Cables [FC700C]	02	17,623	35,246
03	Mackie FRS 1700 / 1660W Professional Lightweight Stereo Power Amplifier	06	41,825	250,950
04	VR61 Black / The VR61 compact full-range loudspeaker offers a specially engineered, purpose-designed 6-inch LF driver that enables it to match the output of competitive 8-inch 2-way designs.	20	36,912	738,240
05	NTL720 Black 230 VAC / A true three-way design delivering big-time performance with maximized vocal clarity. Next, the entire enclosure face is filled by a full-sized mid/high horn providing 110-degree (horizontal) by 12-degree (vertical) dispersion.	02	359,253	718.506

All payments requested by "Account payee" instruments only

Sub Total:
Vat @ 12.5%
Grand Total

1,955,572.00
244,447.00
2,200,019.00

(Twenty Two Lakh & Nineteen Only)

For Resonators,

A.P.Srinivas

Terms & Condition :

Payment as 100 % advance DD against Delivery .
Freight and Freight insurance will be additional at actual .
Delivery immediate if in stock or 4 - 8 weeks from the date of Confirmed order along with 50 % advance .
Proforma Invoice is valid for 30 days .

905/37,4th Main, 3rd Cross, Vidydranyapuram, Mysore-570008, Karnataka, INDIA.

Ph : (0821) 2482113 , 2481679. Mobile : 9880535569 , 9845135569.

Email : srinirec@hotmail.com , fluteprasad@rediffmail.com

(71)

CP 6/3
CP 6/3
CP 6/3

68

Date: 03/03/2010

To,
Kalakshetra Foundation,
Thiruvanmiyur,
Chennai-600041.

Kind Attn: Ms Leela Samson

Sub: Supply of Audio Equipment .

Please find enclosed herewith the Pro Forma Invoice for the Audio Equipment as per your requirement.

Freight will be extra at actual.

Delivery : 6-8 weeks from receipt of Confirmed order.

Payment Terms: 100% advanced against delivery.

Validity : Proforma Invoice valid for 30 days.

For Resonators.

Srinivas

Authorized Signatory.

(72)

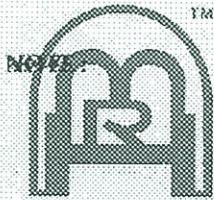

MRH DIGITAL SYSTEMS™ PRIVATE LIMITED

Skanda Krupa, No. 191, 1st Cross, 38th Main, BOOHBCS,
BTM 11nd Stage, Bangalore - 560 068, INDIA.
Phone : (91-80) 4120 0571/72/73, Fax : (91-80) 4120 0574

TO
KALAKSHETRA FOUNDATION
THIRUVANMIYUR
CHENNAI - 600041

DATE:02.03.10

KIND ATTN: MS. LEELA SAMSON

QUOTATION

SL NO.	MODEL/DESCRIPTION	UNIT RATE	QTY.	AMOUNT
1	UB82e Black / The UB82e has a compact vented rectangular enclosure and is engineered to provide very high output and wideband response in distributed applications.	104,328.00	2	208,656.00
2	KF750/KF755 Spare Fly Clip/Cables [FC700C]	17,294.00	2	34,588.00
3	Mackie FRS 1700 / 1660W Professional Lightweight Stereo Power Amplifier	40,663.00	6	243,978.00
4	VR61 Black / The VR61 compact full-range loudspeaker offers a specially engineered, purpose-designed 6-inch LF driver that enables it to match the output of competitive 8-inch 2-way designs.	30,335.00	20	606,700.00
5	NTL720 Black 230 VAC / A true three-way design delivering big-time performance with maximized vocal clarity. Next, the entire enclosure face is filled by a full-sized mid/high horn providing 110-degree (horizontal) by 12-degree (vertical) dispersion.	352,538.00	2	705,076.00
TOTAL				1,798,998.00
SALES TAX @ 12.5%				224,874.75
GRAND TOTAL				2,023,872.75

NOTE:

1. FREIGHT WILL BE EXTRA AT ACTUALS.
2. DELIVERY : 8-10 WEEKS FROM RECEIPT OF COMMERCIALY CLEAR PURCHASE ORDER
3. PAYMENT TERMS :100% ADVANCE WITH PURCHASE ORDER.
4. VALIDITY: 30 DAYS

FOR MRH DIGITAL SYSTEMS PVT. LTD.

T.S.SRIRAM
BUSINESS HEAD - SOUTH
Mobile : 93417 33603

73

CP
AS AD/80
CP 6/3

70

Date: 04/03/2010

To,

Kind Attn: Ms Leela Samson

Kalakshetra Foundation,

Thiruvanmiyur,

Chennai-600041.

Sub: Supply of Audio Equipment .

Please find enclosed herewith the Pro Forma Invoice for the Audio Equipment as per your requirement.

Freight will be extra at actual.

Delivery : 8-10 weeks from receipt of commercially clear Purchase Order.

Payment Terms: 100% advance with purchase order.

Validity :30 days.

Kindly acknowledge receipt of the letter.

For MRH Digital Systems Pvt Ltd.

Authorized Signatory.

(74)

71

Import contacts from Yahoo, Outlook, and others into your Kal

You are currently using 137 MB (1%)

Last account activity: 3 days ago at this IP (12
Kalakshetra.in Mail view: standard | [turn off chat](#) | [older ve](#)

©2009 Google - [Terms of Service](#) - [Privacy Policy](#) - [Prc](#)

Powered by 

75
160

you. If the project is going to be simplified or spread over a longer time we could break it up in instalments - per phase. But we would like to get a part of them processed as soon as possible. Kindly give your thoughts about it.

Warm Regards

Didier

Sound Wizard
Acoustics & Pro-audio

Shakti
Auroville 605 101
Tamil Nadu, India
Phone (0) 413 262 26 59
Phone (0) 413 262 24 80
Phone (0) 413 262 24 82
Fax (0) 413 262 34 10

<http://www.soundwizard.net>

(76)

Fwd: Planning Inbox X

from **Director Kalakshetra** <director@kalakshetra.in>
 to works@kalakshetra.in
 date Sat, Oct 31, 2009 at 7:15 PM
 subject Fwd: Planning

[hide details](#) Oct 31 (3 d

----- Forwarded message -----

From: **Didier** <didier@soundwizard.net>
 Date: Tue, Oct 27, 2009 at 3:43 PM
 Subject: Re: Planning
 To: Leela Samson <leelasamson@gmail.com>
 Cc: Leela Samson <leelasamson@kalakshetra.in>

Dear Leela,

I tried top call but I understood you are out of the country.

Let us put our fees request on hold for the time being, till you are back, nothing urgent.

On the side of the new installation planning, could you please clarify wether the roof work is going to start from is already done and we need to start acoustics & equipments installation.

We might have a problem with this further delay, in the sense that all agreed prices on equipment are going to the suppliers quite drastically). Several suppliers called us telling that they cannot hold their rates anymore. W everything on hold for a few more days. So, unless the purchase is done quickly, budget will have to be revise scaled down. Then all the design, preparation, multiple quotes, accounts checking, etc... will be lost because \ scratch again...

I know you already are under a lot of constrains and stress for this upgrade, but please give your feedback AS

Have a nice journey :-)

Didier

On 26-Oct-2009, at 5:05 PM, Leela Samson wrote:

dear didier,
 sure, we can work it out as you like. please let us know what is good for you from the time we order. the time line will have to depend upon when the stuff arrives. that depends upon when the order goes out. i have the audi free from jan 22 till whenever - 6 months and sort of think most of the stuff will happen then.
 regards
 leela

On 10/26/09, Didier <didier@soundwizard.net> wrote:

Dear Leela,

I hope you are fine and that life is creative, harmonious and happy.

I wanted to get your feedback on 2 points:

- Since we have very little knowledge on the time line for the auditorium update, I would like you to give us a tentative planning, if possible. I will have to go abroad during the next months for a technical training for a few weeks, I would not want to be outside the country when my expertise is fully required for the project.

- Also, we have to assess our fees, based on the latest contract sent to

(77)

think most of the stuff will happen then.
regards
leela

On 10/26/09, Didier <didier@soundwizard.net> wrote:

Dear Leela,

I hope you are fine and that life is creative, harmonious and happy.

I wanted to get your feedback on 2 points:

- Since we have very little knowledge on the time line for the auditorium update, I would like you to give us a tentative planning, if possible. I will have to go abroad during the next months for a technical training for a few weeks, I would not want to be outside the country when my expertise fully required for the project.

- Also, we have to assess our fees, based on the latest contract sent to you. If the project is going to be simplified or spread over a longer time we could break it up in instalments - per phase. But we would like to get a part of them processed as soon as possible. Kindly give your thoughts about it.

Warm Regards

Didier

Sound Wizard
Acoustics & Pro-audio

Shakti
Auroville 605 101
Tamil Nadu, India
Phone (0) 413 262 26 59
Phone (0) 413 262 24 80
Phone (0) 413 262 24 82
Fax (0) 413 262 34 10

<http://www.soundwizard.net>

[Reply](#)

[Forward](#)

director is not available to chat

[« Back to Inbox](#)

[Archive](#)

[Report spam](#)

[Delete](#)

[Move to](#)

[Labels](#)

78

Start Page Mail Calendar Documents Sites

kalakshetra

 Search Mail

 Search the Web

 Shc
Cre

Compose Mail

Inbox

Sent Mail

Drafts

Spam (5)

Follow up

Misc

Priority

4 more

Contacts

Chat

 Search, add, or invite

Works kalakshetra

Set status here

Admin Kalakshetra

director

Arul Jothi Mani G -Trai...

bepI

cao

christopher

christopher

contactus

cumiceramicsranipet

leelasamson

Options

Add Contact

noise control - www.acousticsonic.com - acoustic consultant acoustic measureme

« Back to Inbox

Archive

Report spam

Delete

Move to

Labels

Fwd: Planning

Inbox X

from **Director Kalakshetra**

hide details Oct 31 (3 days)

<director@kalakshetra.in>

to works@kalakshetra.in

date Sat, Oct 31, 2009 at 7:15 PM

subject Fwd: Planning

----- Forwarded message -----

From: **Didier** <didier@soundwizard.net>

Date: Tue, Oct 27, 2009 at 3:43 PM

Subject: Re: Planning

To: Leela Samson <leelasamson@gmail.com>

Cc: Leela Samson <leelasamson@kalakshetra.in>

Dear Leela,

I tried top call but I understood you are out of the country.

Let us put our fees request on hold for the time being, till you are back, nothin

On the side of the new installation planning, could you please clarify wether th to start from Jan 22nd or this item is already done and we need to start acous installation.

We might have a problem with this further delay, in the sense that all agreed p are going to go up (and for some of the suppliers quite drastically). Several su telling that they cannot hold their rates anymore. We asked them to keep ever few more days. So, unless the purchase is done quickly, budget will have to b equipment list scaled down. Then all the design, preparation, multiple quotes, etc... will be lost because we would start from scratch again...

I know you already are under a lot of constrains and stress for this upgrade, b feedback ASAP on the above.

Have a nice journey :-)

Didier

On 26-Oct-2009, at 5:05 PM, Leela Samson wrote:

dear didier,

sure, we can work it out as you like. piease let us know what is good for you from the time we order. the time line will have to depend upon when the stuff arrives. that depends upon when the order goes out. i have the audi free from jan 22 till whenever - 6 months and sort of

79

SOUND WIZARD

Audio Design and Consultancy

SOUND WIZARD

Shakti - Auroville 605 101

Tamil Nadu - India

Tel : 0413 2622659 Fax : 0413 2623410

Email : soundwiz@auroville.org.in

Website : www.soundwizard.net

Kind Atten Mr. Srinivasan,

TO:

M/s: Kalakshetra Foundation
Rukmani Devi College of Fine Arts/
Kalakshetra Road / Thiruvannamiyur /
Chennai - 600 041

PH: CHH) 24 52 11 69

cell: 98 407 62 646

80/11/11 ✓

80

Approval /obtained/brand to be supplied value	Change of the supplier and Brand and value as suggested	Difference In cost
EAW products Microphone--- Rs.6,88,849 5% discount 34,442 - 6,54,407	M/s.Sennheiser/India Micro phone -- Rs. 6, 73,047	(+) 18,640
Speaker system Balance items -Rs.19,12,500 5% Discount - 95,625 - 18,16,875	M/s.E & E Systems India Speaker systemRs. 19,27,487	(+)1,10,612
Total 24,71,282	26,00,534	+1,29,252

Based on M/s.Aditya info tech pvt ltd reply letter and in view of urgency / concurrence of the consultant, the supply order for above two agencies may be issued to complete in time.

Based on the letter we received from M/s.Aditya InfoTech pvt ltd, we may write a letter to him stating that the extra amount incurred due to his non-supply of materials will have to be borne by him.

Re-submitted for approval of change of the supplier to M/s.Sennheiser /India for Microphone supply order for the value of Rs.6, 73,047/- and M/s.E & E Systems India for Speaker systems for Rs.19, 27,487/- please.

DIRECTOR

P.T.KRISHNAN

Drawn for approval please,

(81)

A
20C
18/3/110
AD

CAO

Aulad
18/3
DIRECTOR

- 2-

For supplying of Micro phones, the received quotes from suppliers, details and comparative statement (placed below) **Annexure VIII**

Sl. No.	Name of the suppliers	Quoted value	Position	Total cost to be awarded-L1
1	M/s.Sennheiser India Pvt Ltd	Rs.6,73,047/-	L 1	Rs.6,73,047/
2	M/s.Sasi Enterprises	Rs7,34,966/-	L 2	
3	M/s.Telerad	Rs.7,20,967/-	L 3	

The consultant approved and recommended the M/s.Senheiser India Pvt ltd, brand and specification and requested to place the supply order on them, at a total cost of Rs.6, 73,047/- **Annexure X**

For supplying of speaker (balance) updated version, the received quotes from suppliers and details, (placed below) **Annexure IX**

Sl. No.	Name of the suppliers	Quoted value	Position	Total cost to be awarded-L1
1	M/s.E & E systems /Bangalore	Rs.19,27,488/	L 1	Rs.19, 27,488/Freight and Insurance will be additional at actual.
2	M/s.MRH Digital systems pvt ltd, Mumbai	Rs20,23,878-	L 2	
3	M/s.Resonaltors Bangalore	Rs22,00,019/-	L 3	

The consultant approved and recommended the M/s.E& E systems /Bangalore, brand and specification and requested to place the supply order on them, at a total cost of Rs.19, 27,488/- **Annexure X**

The details of difference between old supplier, specification /brand and Revised selected model, brand and change of supplier name and their offer value and difference in cost for old supplier and present are tabulated below.

..... 3

(82)

C:\ 2009-2010\V.Admin\2. Engineering\i.Plan\Sound equipments .doc

March 18, 2010

Sub: **Note – Re-Submission** - Koothambalam – Sound equipments - EAW
And Audix products – **Change of suppliers** – Approval of - Reg.

Ref: Approval dated 6.11.2009 (placed below please)

Remarks pointed out in the note dated 18.2.2010 by Sri.P.T.Krishnan

In continuation to the office note as cited in the above reference, and in tune with the advice contained in the remarks , the following steps have been taken and resubmitted for approval.

- The termination of contract / Supply order, was issued to the agency M/s.Aditya info Tech Limited, Nungambakkam, based on the recommendation / remarks given by the consultant M/s.Sound wizard. The receipt of the letter of termination of supply order (Balance materials) was received from the postal acknowledgement on 29.12.2010. **Annexure VI**
- Further, the reason for Non-supply of the balance materials as per the work order from M/s.Aditya InfoTech ltd has been received. **Annexure VII**
- Since the model, specification of the equipment has been changed/selected by the consultant M/s.sound wizard, further quote from the M/s.Aditya InfoTech ltd, was not appraised by the consultant.
- The fresh quotations for the supplying balance sound equipments (as per the list) as per the selected models and changed specifications equipments were called by the consultant from various manufactures and brand, and the quotes were received by the Foundation as directed.

..... 2



1/5

90

Microphones previous option	Brand	Qty	Model	Specifications	Rate	Price	Total Incl. Tax
Quote from Aditya Infotech							Rs.6,88,849
Gooseneck	Audix	3	Micropod 18HC	M1250 with Flexible gooseneck 18"	Rs.22,125	Rs.66,375	
HandHeld Transmitter with Mic	Audix	4	W3-OM5	RAD-360 System with OM5 dynamic transmitter	Rs.44,000	Rs.1,76,000	
BodyPack System	Audix	4	W3-BP	RAD-360 Bodypack System with transmitter	Rs.35,750	Rs.1,43,000	
MiniMic Headworn	Audix	4	HT5-BG	Slim-line headset vocal condenser	Rs.16,875	Rs.67,500	
Lavalier	Audix	4	ADX10	Miniaturized lavalier condenser	Rs.10,875	Rs.43,500	
BodyPack System (accessory)	Audix	4	W3-BP	To use HT5 or ADX10 wired	Rs.35,750	Rs.1,43,000	
Lavalier Accessories	Audix	4	APS-911	Windscreen	Rs.950	Rs.3,800	
Lavalier Accessories	Audix	4	WS10S	Metal Clip	Rs.1,045	Rs.4,180	
Lavalier Accessories	Audix	4	MC10L	Battery/Phantom power adapter	Rs.3,750	Rs.15,000	
Microphones updated version							
Quote from E&E Systems India							Rs.6,73,047
Gooseneck	Sennheiser	3	MZH 3040	40 cm	Rs.10,000	Rs.30,000	
Capsule	Sennheiser	3	ME 34	Cardiod for gooseneck	Rs.7,900	Rs.23,700	
Table Stand	Sennheiser	3	MZTX 31	Without Switch	Rs.9,550	Rs.28,650	
Windscreen	Sennheiser	3	MZW 36 Pro	For gooseneck	Rs.2,899	Rs.8,697	
HandHeld Transmitter with Mic	Sennheiser	3	EW 100-835 G3	Handheld Set	Rs.41,000	Rs.1,23,000	
MiniMic Headworn	Sennheiser	6	HSP4	Slim-line headset vocal condenser	Rs.35,500	Rs.2,13,000	
Lavalier	Sennheiser	6	Ew 122 G3	Miniaturized lavalier condenser	Rs.41,000	Rs.2,46,000	

Speaker system (balance) - previous option	Brand	Qty	Model	Specifications	Rate	Price	Total Incl. Tax
Quote from Aditya Infotech							Rs.19,12,500
Line Array (H:47/1.20m W:24"/0.60m)	EAW	2	NTL720	500W/500W/500W	Rs.3,35,750	Rs.6,71,500	
Flying Cables	EAW	2	KF750	For Subs	Rs.15,250	Rs.30,500	
Front Fill Speaker	EAW	4	UB52	150W/8Ω	Rs.64,750	Rs.2,59,000	
Speakers down + balcony	EAW	20	VR61	300W/8Ω	Rs.26,750	Rs.5,35,000	
Amplifiers	EAW	6	CAZ1400	450W/4Ω	Rs.34,000	Rs.2,04,000	
Speaker system (balance) - updated option							
Quote from Sennheiser India							Rs.19,27,487
Line Array (H:47/1.20m W:24"/0.60m)	EAW	2	NTL720	500W/500W/500W	Rs.3,35,750	Rs.6,71,500	
Flying Cables	EAW	2	KF750	For Subs	Rs.16,470	Rs.32,940	
Front Fill Speaker	EAW	2	UB82	150W/8Ω	Rs.99,360	Rs.1,98,720	
Speakers down + balcony	EAW	20	VR61	300W/8Ω	Rs.28,890	Rs.5,77,800	
Amplifiers	Mackie	6	CAZ1400	450W/4Ω	Rs.38,727	Rs.2,32,362	

89

81

2/11

Change of supplier required - urgent

Inbox X

from **Didier** <didier@soundwizard.net> [hide details](#) Feb 8 (3 days ago) [Reply](#)

to "Leela Samson ."
 <leelasamson@kalakshetra.in>,
 "Kalakshetra - Srinivasan ."
 <works@kalakshetra.in>
 cc "Leela Samson ."
 <leelasamson@gmail.com>,
 "-Kumbha SW ."
 <kumbha@soundwizard.net>,
 "-Fabien ." <fabien@soundwizard.net>

date Mon, Feb 8, 2010 at 3:25 PM

subject Change of supplier required - urgent

Dear Leela,

We had a busy and tough time lately: one of the main supplier (Aditya Infotech) has not been clear on the supply timeline of 2 remaining batch of items:

- 1/ The full microphone line, to complement the one already purchased a year ago.
- 2/ All balance items for the speaker system (main, monitoring, surrounds)

We tried to get shipping lists, custom papers, etc... we even recently contacted the factories: Most of the pending items had not been sent to India yet.

We understood that for all EAW products (speaker system) the network had been changed in India. After detailed enquiries it seems for the best, with a very strong presence and a new support team and big service center.

SPEAKERS:

So, we suggest this order to be shifted from Aditya Infotech to the new channel, namely E&E Systems India. We can take the opportunity to slightly reshuffle front field speakers with new models that give more coverage and more power with less items, within the same budget. So we could replace the 4 small front fields by 2 new bigger/better ones, that still fit embedded within the stage front steps.

MICROPHONES:

Considering the lack of communication with Aditya Infotech we would like not to take a chance on further delays, and we prefer switching the whole microphone order to another very good brand that is Sennheiser (from Germany). We can also get all items within the same budget with a slight update on models.

So budget would be almost identical, as well as specifications. But time-line restarts from scratch that is 4 to 6 weeks from the date of your green light. The main difference is that these channels will be more reliable for the present delivery and for the future support.

Attached is a list with previous supplier / new supplier items.
 Waiting for your feedback,

Warm Regards,

Didier

Sound Wizard
 Acoustics & Pro-audio

Shakti #9
 Auroville 605 101
 Tamil Nadu, India
 Phone (0) 413 262 26 59
 Phone (0) 413 262 24 80
 Phone (0) 413 262 24 82
 Fax (0) 413 262 34 10

<http://www.soundwizard.net>

AS

*11.2.10
 AO*

CAO

85

Pl apprise PIR.

*Caladiff
 DIRECTOR*

C:\ 2009-2010\V.Admin\2. Engineering\i.Plan\d.Sound systems\koothambalam.doc

January 18, 2010

Sub: Up gradation of Sound system in Koothambalam – supply of EAW and Audix Products – Extension of time - requested – Reg.

Ref: Work committee approval dated 6.11.2009 - P 02
 M/s. Aditya InfoTech letter dated 07.11.2009. - P 15
 Revised letter from M/s.Aditya Info tech dated 7.11.2009 P20
 Approval note dated 7.11.2009 - P 16

Email from the supplier M/s.Aditya Info tech 18.1.10 -P 34

The supplying of EAW and Audix products was placed on M/s.Aditya info tech , based on the approval by the Works Committee as recommended by the consultant M/s.Sound wizard.

One shipment equipment as part of the supply order was delivered by the M/s.Aditya InfoTech at a total cost of Rs.36,98,944/- as against total supply order of value of Rs.61,70,870/-

As per the terms, the supply order should be completed by 20.10.2010 in all respects. Further the status of the supplier was clarified by email. The supplier had sent the email that they needed 3 months to effect the balance materials till **01.03.2010 without fail.**

Forwarded the same to M/s.Sound wizard, for their comments.

Submitted for approval for giving the extension of time till 01.03.2010 to M/s.Aditya Info Tech.

[Handwritten signature]
 EO
[Handwritten signature]
 AO
 19/1/10
[Handwritten signature]

[Handwritten signature]
 CAO
 19/01/10

[Handwritten signature]
 19/1
 DIRECTOR

(86)

All materials as per specification
has been checked. Approved for
payment.



For Sound Wizard
26-11-2009

CP
26/11/09

SOUND WIZARD
Shakti-Auroville 605 101
Tamil Nadu-India
Tel : 0413 2622659 Fax : 0413 2623410
Email : soundwiz@auroville.org.in
Website : www.soundwizard.net

(87)

65
5
19

Aditya Infotech Ltd.-Chennai - (From 1-Apr-2009)
 Flat No.3, 2nd Floor,
 City Star Millenium Tower
 No.29, Temple Avenue, Srinagar Colony
 Sidapet, Chennai - 600015
 TIN No. 33130862932
 C.S.T No. 837197
 SERVICE TAX NO.:AABCA1601RST009

Invoice No. **AIL/CHN/TX/09-10/0920** 84
 Invoice Date **25-Nov-2009**
 Delivery Note No. & Date :
 Order No. & Date : C:/2009-2010 Dt. 9-Nov-2009
 Despatch Document No. :

Bill To
KALASHETRA FOUNDATION
 THIRUVANMIYUR
 CHENNAI - 600041
 PH. 044-24520826 / 4057
 TIN No. :

Ship To
KALASHETRA FOUNDATION
 THIRUVANMIYUR
 CHENNAI - 600041
 PH. 044-24520826 / 4057
 TIN No. :

ADITYA INFOTECH LIMITED
 No: 20, KOTHARI ROAD,
 MUNGAMBAKKAM,
 CHENNAI - 600 034.
 TIN No: 33130862932
 CST No: 837197

Dealer Name : Kalashetra Foundation	End User Name :	Despatched through DELIVERED
Supplier's Ref.	Destination CHENNAI	Mode/Terms of Payment
Other Reference(s)	Terms of Delivery	

S.No.	Description of Goods	Quantity	Rate	per	Amount
1	66005 EAW NTL 720 LINE ARRAY	8 Pcs	3,35,750.00	Pcs	26,86,000.00
2	66017 EAW NTS22 BLACK	2 Pcs	2,46,625.00	Pcs	4,93,250.00
3	66019 EAW FB172 FLYBAR	2 Pcs	1,40,875.00	Pcs	2,81,750.00
ORDER REF.NO.C:/2009-2010/V. ADMIN2.ENGINEERING/I.PLAND.SOUND SYSTEMS/KOOTHAMBALAM.DOC DT.09.11.2009.					
Less :		Trade Discount		(-5) %	(-1,73,050.00)
		Output VAT 12.5%		12.50 %	4,10,993.75
		Round Off Sales			0.25
		Total			36,98,944.00

SECURITY Dept.
 25/11/09
 (67)

KALAKSHETRA FOUNDATION
 THIRUVANMIYUR,
 CHENNAI - 600 041.

Amount Chargeable (in words)
Rs. Thirty Six Lakh Ninety Eight Thousand Nine Hundred Forty Four Only

TERMS & CONDITIONS

- All contracts shall be deemed to have been entered into at Delhi and in case of any dispute all proceedings if any shall be filed and litigated in the civil courts of Delhi and no where else.
- Our responsibility ceases the moment goods leave our godown. And goods once sold will not be taken back.
- We are not responsible for any delay or deterioration/breakage due to negligence of the carriers etc.
- In case of any variation in quality/quantity, the entire material must be kept separate for our verification. No claims or deduction will be acceptable without our verification. In case material is sold prior to our inspection no claim will be acceptable.
- The customer/consumer will not hold Aditya Infotech Ltd.-Chennai - (From 1-Apr-2009) responsible for, or liable for, any civil, criminal action, claims, demands, losses, damages, costs, charges and expenses, which customer/consumer may suffer, sustain or incur after the delivery of goods.
- In the absense of proper sales tax certificate, if not already sent, the sales tax as applicable along with any panel charges shall be recoverable.
- It is hereby informed that Aditya Infotech Ltd.-Chennai - (From 1-Apr-2009) is a marketing and distribution company and is not manufacturer, warranty, if any on the goods sold will be covered as per the policy and terms & conditions of the manufacturer.
- Any increase in excise duty/tax/octroi or any other government levy will be charged extra from the customer.
- Payment against this invoice will not be held for any pending claims of whatsoever nature.
- Payment by A/c payee cheque/demand draft. Outstation payment to be made by demand draft only.
- A charge of Rs. 250 plus interest @24% per annum shall be levied extra against each bouncing of cheque besides civil/criminal action.
- Overdue interest shall be charged @24% from the date of the bill.
- While making payment please quote our invoice no.
- Rates subject to revision without any prior notice.
- Protest waived.

For Aditya Infotech Ltd.-Chennai - (From 1-Apr-2009)

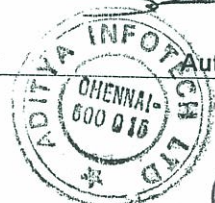
[Signature]
 Authorised Signatory

*Def. Subject to approval
 25/11/09 - 14:57pm*

88

Kalakshetra

ANNEXURE



22
6/19

Sl. No.	Unit	Qty.	Price Per unit (INR)	VAT (%)	Unit Value Excluding VAT
1.	EAW NTL 720 Line Array	10	3,35,750/-	12.5	33, 57,500-00
2.	EAW NTS22 Subwoofer	2	2, 46,625/-	12.5	4, 93,250-00
3.	EAW FB172 Fly Bar for NTL 720	2	1, 40,875/-	12.5	2, 81,750-00
4.	EAW KF 750 Cables - FC700C	2	15, 250/-	12.5	30, 500-00
5.	EAW UB52i Loudspeaker	4	64,750/-	12.5	2, 59,000-00
6.	EAW VR61 Front Fill Speaker	20	26, 750/-	12.5	5, 35,000-00
7.	EAW CAZ 1400 Amplifier	6	34, 000/-	12.5	2, 04,000-00
8.	Audix Micropod 18HC Gooseneck Microphone	3	22, 125/-	4.0	66, 375-00
9.	Audix W3-OM5 Handheld Transmitter with Mic	4	44, 000/-	4.0	1, 76,000-00
10.	Audix W3-BP Body Pack System	4	35, 750/-	4.0	1, 43,000-00
11.	Audix HT5-BG Slim Line Headphone Microphone	4	16, 875/-	4.0	67, 500-00
12.	Audix ADX 10-P Lavalier Microphone	4	10, 875/-	4.0	43, 500-00
13.	Audix W3-BP Body Pack System	4	35, 750/-	4.0	1, 43,000-00
14.	Audix APS-911 Battery Phantom Power Adapter	4	3, 750/-	4.0	15, 000-00
15.	Audix WS10S External Wind Screen	4	950/-	12.5	3, 800-00
16.	Audix MC 10L Metal Clip	4	1, 045/-	12.5	4, 180-00
			Total Value Excluding VAT		58, 23,355-00
			Discount 5% (-)		55, 32,187-00
			VAT 12.5% (+)		6, 13,816-38
			Vat 4% (+)		24, 866-25
			GRAND TOTAL		61, 70,869-63
			(Rupees sixty one lakhs seventy thousand eight hundred and thirty four only)		Or
			Rounded to		61, 70,870-00

To
M/s. Aditya Infotech Ltd.,
Chennai-

89



86

23
7/15
Kalakshetra
FOUNDATION

C:\2009-2010\V.Admin\2. Engineering\L.Flan\d.Sound systems\koothambalam.doc

09 November 2009

M/s. Aditya Infotech Limited,
No, 20 Kothari Road,
Nungambakkam,
Chennai 600 034.

Sir(s)

Sub: Supply of EAW & Audix Products -- Supply order - Reg

Ref: Your offer No. AIL / CHN / 1409 / 001 dated 14.09.2009
Your letter dated 07.11.2009
Your letter dated 10.11.2009

The Director, Kalakshetra Foundation is pleased to award the Supplying of EAW & Audix Products at a total cost of Rs. 61, 70,870/- Nett, as per the Annexure specification, terms and condition, enclosed herewith in all respects. This is a firm rate contract. General term and conditions applicable to this order is attached.

The final payment will be disbursed after the material is approved and certified by the consultant - M/s.Sound wizard.

Delivery time -- 10 weeks from the date of supply order till 20.01.2010.

Warrant as specified in the conditions.

The materials should be delivered at our premises (door delivery) and materials should be covered with Insurance up to Kalakshetra Foundation/Chennai.

The material delivered should be in original packing WITHOUT tampering with the original manufacturer's packing and in good condition.

The above supply order should be effected and completed in all respects by 20.12.2010. **If the progress of the supply is found to be not satisfactory or the total supply is not completed in all respects as per the schedule as mentioned above, this supply order will automatically cease without notice and without assigning any reason.**

Kindly acknowledge receipt of the letter.

Leela Samson
Leela Samson
Director

Received a copy of the work order

[Signature]
13/11/09

90

Founder : Smt. Rukmini Devi Chairman : Justice Sri S. Mohan Former Judge Supreme Court
Director : Ms Leela Samson Member Secretary : Sri R.V. Ramani Governing Board

Kalakshetra Foundation Thiruvanniyur Chennai 600 041
Tel: 0091-(0)44-2452 0836 / 4057 / 1844 Fax : 0091-(0)44-2452 4359
Email : info@kalakshetra.in Website : www.kalakshetra.in

Line 1: (80) 41 20 05 71
 Line 2: (80) 41 20 05 72
 Line 3: (80) 41 20 05 73
 Fax: (80) 41 20 05 74
 M1 name: Poncho
 Mobile 1: (0) 93 437 71 035

- Rivera International for Denon & Pioneer products

First Name: Prasad Patil
 Company: Rivera International
 : # 7-397A-1B / Mangaldas House / Naaz Cinema Compound /
 Lamington Road /
 400 004 Mumbai, Maharashtra
 Line 1: (22) 23 80 05 55
 Fax: (22) 23 86 23 42
 Mobile 1: (0) 93 225 32 349
 Email 1: ppatils@gmail.com

- Promusicals for Samson & Alesis products

First Name: Apollo
 Company: Pro Musicals - Apollo
 : # 25 - Casa Major Road / Egmore /
 600 008 Chennai, Tamil Nadu
 Line 1: (44) 28 19 36 07
 Line 2: (44) 28 19 34 45
 Fax: (44) 28 19 38 23
 M1 name: Apollo
 Mobile 1: (0) 98 843 04 426
 Email 1: apollo_promusic@vsnl.net

- Sun Media Ventures for cabling products

First Name: Umesh Ramdas Bhagwat
 Company: SUN Media Ventures Ltd
 : Flat no:1 - Ground Floor / Krishna Kunj / Ashok Nagar /
 Cross Road No: 3 / Kandivli (East) /
 400 101 Mumbai, Maharashtra
 Line 1: (22) 28 84 37 72
 Line 2: (22) 28 85 41 17
 Fax: (22) 28 84 15 90
 M1 name: Umesh
 Mobile 1: (0) 98 210 38 990
 M2 name: Peter
 Mobile 2: (0) 98 214 36 550
 Email 1: sunmedia@vsnl.com
 Email 2: sunmedia.umesh@gmail.com

- Sassi Enterprises for Telex products

First Name: BalaRaman
 Company: Sassi Enterprises
 : New No: 90 - (Old No: 149) / "Nelson Plaza" /
 Nelson Manickam Road / Choolaimedu /
 600 094. Chennai, Tamilnadu
 Line 1: (44) 23 74 67 61
 Line 2: (44) 23 74 66 61

Line 3: (44) 23 74 37 69
Fax: (44) 23 74 37 69
M1 name: Bala raman
Mobile 1: (0) 94 443 86 661
Email 1: dhayalvr@vsnl.com

- Projection Design for Projection Design products

First Name: Ashok Sharma
Company: Projectiondesign
: Habornveien 53 / N-1630 Gamle Fredrikstad /
Norway
Line 1: (+47) 69 30 45 50
Fax: (+47) 69 30 45 80
M1 name: Ashok Sharma
Mobile 1: (0) 98 206 10 670
Email 1: ashok.sharma@projectiondesign.com

- Office 2000 Solutions for Draper products

First Name: Kamalakkannan / Azharuddin
Company: Office 2000 Solutions Pvt Ltd
: # 16, 19 & 20 - Block II / SIDCO Electronic Complex /
Guindy Industrial Estate /
600 032 Chennai, Tamilnadu
Line 1: (44) 22 50 07 74
Line 2: (44) 22 50 04 99
Line 3: (44) 45 53 22 80
Fax: (44) 22 50 05 50
M1 name: Kamal
Mobile 1: (0) 95 000 20 057
M2 name: Azharuddin
Mobile 2: (0) 95 000 20 053
Email 3: rekha@office2000.com
Email 1: kamal@office-2000.com
Email 2: azhar@office-2000.com

rekha@office-2000.com

Should you require more informations, please feel free to call us.

Best regards,



Didier Weiss

Sound Wizard
Pro Audio Acoustic Design

Shakti Area 9
Auroville 605 101 (Via Pondicherry)
Tamil Nadu, India
Phone (0) 413 262 26 59
Phone (0) 413 262 24 80

www.soundwizard.net

SOUND WIZARD
Shakti-Auroville 605 101
Tamil Nadu-India
Tel : 0413 2622659 Fax : 0413 2623410
Email : soundwiz@auroville.org.in
Website : www.soundwizard.net

(92)

89

10
19



Sound Wizard

Acoustics & Pro-audio

Auroville, Oct 13th, 2009

Dear Sir, dear Madam,

As requested by you, we recommend the following parties to supply audio equipment for your main auditorium upgrade:

- Aditya Infotech for EAW & Audix products

First Name: Dhruv Datta
Company: Aditya Infotech Ltd
: #12-13 & 15-A - Janki Centre / 29 - Shah Industrial Estate /
Off. Veera desai road / Andheri (west) /
400 053 Mumbai
Line 1: (22) 26 74 15 95
Line 2: (22) 26 74 15 96
Line 3: (22) 26 74 15 98
Fax: (22) 26 74 15 00
M1 name: Dhruv Datta
Mobile 1: (0) 93 218 94 353
Email 1: dhruv_datta@adityagroup.com

- Ansata Computers for Digidesign products

First Name: Leslie J.Lean
Company: Ansata
: # 53 - C.K. Garden / Wheeler Road Extn /
560 084. Bengalooru, Karnataka
Line 1: (80) 25 46 51 44
Line 2: (80) 25 46 46 55
Fax: (80) 25 47 94 94
M1 name: Leslie
Mobile 1: (0) 99 003 17 537
Email 1: leslie.lean@ansata.net

- MRH Digital for QSC products

Last Name: QSC Business Head
First Name: Poncho (S. Gopinadhan)
Company: MRH Digital System Pvt. Ltd
: Skanda Krupa / # 191- 1st Cross / 38th Main /
BOOHBCS / BTM Layout II Stage /
560 068 Bengalooru, Karnataka

93

13/10/09

90

19

Sound Wizard
Acoustics & Pro-audio
Shakti Area 9, Auroville 605 101 (via Pondicherry), Tamil Nadu, INDIA
Phone +91 (0) 413 2622 659, -480, -482 <http://www.soundwizard.net>

To:

Kalakshetra Foundation - Rukmani Devi College of Fine Arts
Kalakshetra Road, Thiruvanmiyur
600 041 Chennai
Tamil Nadu, INDIA

Date: 09 October, 2009

Subject: Responsibility for equipment specification compliance and installation.

Dear Ms. Leela Samson,

Sound Wizard will be responsible to aid the Kalakshetra Foundation to ensure that all audio video equipment for the renovation of the auditorium is supplied and installed as our specifications.

Our support will cover:

- Receipt of materials as per the specification
- Inspection of quality and condition of the equipments
- Confirmation of quantity
- Testing and certification of equipment
- Supporting installation for all the acoustical works
- Supervision for all audio video equipment installation
- Technical supervisor may be deputed for checking level
- Certification of payment to the supplier/agency/contractor

Equipment supply order should be placed directly to the agencies after discussing the payment conditions and mode of the despatch / delivery of materials to your site.

At your service for any clarification.

Sincerely,

For Sound Wizard



Kumbha Young Grenier

(64)

12/19

5

	DESCRIPTION OF WORK AND MATERIALS	NAME OF THE SUPPLIERS	QUOTED VALUE In Rs.	POSITION	TOTAL COST AWARDED - L 1
7	For Telex Products	M/s.Sasi Enterprises-Chennai.94	293370.75		293370.75
8	For Projection Design - Projectors	M/s. Projection Design Products Norway country 21400 USD \$ @Rs.45/USD	963000.00		963000.00
9	For Draper products	M/s.Office 2000 solutions pvt ltd, Guindy -Chennai 32.	463550.00		463550.00
10	For sound proofing work		1500000.00		1500000.00
11	Consultant charges		250372.00		250372.00
12	Implementation works to be done on site		12,64,125.00		1264125.00
13	Unforeseen items				1630000.00
14	Miscellaneous and Overheads				2789500.00
			Total	In Rupees	2,20,00,000.00

25

13/19

	DESCRIPTION OF WORK AND MATERIALS	NAME OF THE SUPPLIERS	QUOTED VALUE In Rs.	POSITION	TOTAL COST AWARDED - L1
4	For Denon & Pioneer Products	M/s.RIVERA International-Mumbai. 4	189187.50	L 1	189187.50
		M/s.Thump - Mumbai .18	200496.88	L 2	
		M/s.Audio control - Navi Mumbai.703	206082.50	L 3	
5	For Samson & Alesis Products	M/s.Pro Musicals- Chennai .8	228685.00	L 1	228685.00
		M/s.i Media international - Chennai.8	240110.00	L 2	
		M/s.Susan Electronics-Chennai.8	254080.00	L 3	
6	For Cabling products	M/s.Sun Media Ventures Pvt ltd, Mumbai101	762651.00	L 1	762651.00
		M/s.Frontiertech consultancy. - Thane.603	843138.00	L 2	
		M/s.Envoy Marketing and Distributors-Mumbai 28.	900547.00	L 3	

96

6

BID EVALUATION CRITERIA (BEC) FOR SOUND EQUIPMENT IN KOOTHAMBALAM

DESCRIPTION OF WORK AND MATERIALS	NAME OF THE SUPPLIERS	QUOTED VALUE in Rs.	POSITION	TOTAL COST AWARDED - L1
1 Supplying of EAW & Audix products	M/s.Aditya InfoTech - Chennai .15	6186336.00	L 1	6186336.00
	M/s.Sriram Studio - Chennai 26	7159260.00	L 2	
	M/s.Proserve Business - Chennai.83	7476100.00	L 3	
2 For Digidesign products	M/s.Anasta computers - Bangalore.	3353951.25	L 1	3353951.25
	M/s.Audio Care - Chennai.116	3699292.50	L 2	
	M/s.Media Link Concepts - Chennai.26	3857625.00	L 3	
3 For supplying of QSC Products	M/s.MRH Digital systems-Mumbai. 7	844771.50	L 1	844771.50
	M/s.Calibre -Mumbai. 7	862425.00	L 2	
	M/s.Ankur electronics - Mumbai. 34	874912.50	L 3	

- 2 -

For Telex products, Digital Projector Design products and Draper products, we could not get competitive quotations. However, due to urgency of the work (this work has to be completed before the start of December festival), and the suppliers for other products have been identified, we may go for the supply for these products under the rates given by them, if approved please.

If approved, the suppliers quoted 'L 1' rates for the different products identified by BEC may be approved for issue of supply orders, terms and conditions specified therein.

Administrative approval may please be given for Rs.2.20 crores (Rupees two crore and twenty lakh only) for supply of these products initially. The detail for this administrative approval is given in Annexure II.

The working committee, after viewing the presentation made of various consultants, nominated Sri Ravi Nilakanta as a Consultant Architect for this job. The sound proofing (Acoustic Panel fixing) work will be undertaken through the contractor after obtaining the Bill of Quantities (BOQ) and specification from the consultant.

BEC also includes some sound proofing work, consulting charges and implementation of works to be done to give an inside view of the total amount involved for this work. However, along with sound equipment work, sound proofing works also to be taken side by side in consultation with M/s.Sound Wizard with the reputed contractors in the same field as identified by the consultant

General terms and conditions to be attached to the supply order to be given are also placed below for approval please.

Lela Samson
DIRECTOR 21/10'09

P.T. Krishnan
P.T.Krishnan 6/11/09

②



रसो वै सः

957
Kalakshetra
F O U N D A T I O N
16/10/09
28

C:\2009-2010\IV.Director\2.Official\Works.doc

31 October 2009

Sub: Up gradation of Sound system in Koothambalam - Reg

During the 32nd Governing Board meeting held on 7th April 2009, civil works an Advisory Committee was formed to advise the Director in finalizing various contracts towards works undertaken by Kalakshetra foundation during coming years.

One of the major works, which was highlighted by the Secretary, Ministry of Culture, and New Delhi during the visit to Kalakshetra in September 2009, is up gradation of Sound equipment in Koothambalam. For executing this work, simultaneously along with working committee, M/s. Sound Wizard, an expert in sound equipment installations was also engaged as a expert advisor for this project. The selection of Sound Wizard as an expert advisor for the procurement of this equipment was also made a mention to the Governing Board.

For supply of Audio equipments in Koothambalam, Sound Wizard the technical experts has obtained various quotations for the materials required for the job. Based on the quotations received, we have now formalized Bid Evaluation Criteria (BEC) for supply of audio equipments to Koothambalam. From the BEC, it is proposed to issue supply orders to suppliers whose quotation is 'L 1' and who have been certified by M/s. Sound Wizard as the best supplier for the job at the rates specified in the BEC.

..... 2

99

3/10/09

Founder : Smt. Rukmini Devi Chairman : Justice Sri S. Mohan *Former Judge Supreme Court*
Director : Ms Leela Samson Member Secretary : Sri R.V. Ramani *Governing Board*

Kalakshetra Foundation Thiruvanmiyur Chennai 600 04
Tel: 0091-(0)44-2452 0836 / 4057 / 1844 Fax : 0091-(0)44-2452 435
Email : info@kalakshetra.in Website : www.kalakshetra.i

17
19

Dear Leila,

(19)

I have spoken to your CAO.
He will have the LI. suppliers
agree to the delivery location,
insurance + final payment
after inspection and confirm
the same to them in a
separate letter.

The note has been signed.
With kind regards.

P.S

6.11.09

100

-2-

Approval Obtained / brand, to be supplied value	Change of the supplier and Brand and value as suggested	Difference
EAW products Microphone--- Rs.6,88,849	E & E Systems India Micro phone --- Rs. 6,73,047	
Speaker system Balance items --Rs.19,12,500	Speaker system Sennheiser/India Rs.19,27,487	
Total Rs.26,01,349		
5%discount 1,30,068		
Total 24,71,281	26,00,534	+1,29,253

Submitted for approval of change of the supplier to M/s.E & E Systems India for Microphone for the value of Rs.6, 73,047/- and M/s.Sennheiser /India for Speaker systems for Rs.19, 27,487/- please.

Aula Samson

DIRECTOR 16/2 2010

P.T.KRISHNAN

1. There is not only a change of specification, but a change of supplier also. In a situation like this it is necessary to obtain fresh quotations after proper termination of previous contract, to guard against any claims that may be made by the defaulting supplier. This does not appear to have been done.
2. It may be worthwhile to check whether Aditya Infotech is able to supply the modified product suggested by consultants in which case the issue can be treated as a variation and the rate only ~~can~~ revised if found necessary. (101)
3. If (2) above is not possible, then I am afraid we have to go through the procedure in (1) above.

P. T. Krishnan
18.02.10



C:\ 2009-2010\V.Admin\2. Engineering\i.Plan\Sound equipments .doc

February 15, 2010

Sub: Note – Koothambalam – Sound equipments - EAW and Audix products
– Change of suppliers – Approval of - Reg.

Ref: Approval dated 6.11.2009 (placed below please) - **Annexure I**

In continuation of the above approval note, the supply order for supplying of EAW and Audix products was awarded to M/s.Aditya Info Tech /Chennai at a total cost of Rs.61, 70,870/- Nett. - **Annexure II**

The part of the shipment and equipment was supplied by the agency on 25.11.2009 for a value of Rs.36, 98,944/-. The payment was made to the supplier after the inspection / checking, approved and recommended for payment by the consultant M/s.Sound Wizard. **Annexure III**

Balance material (Rs.24, 71,926) supply as per the supply order has not been delivered by the supplier in spite of reminders from us. As per the supply order the materials should have been delivered by supplier before 31.12.2009, but on the request from him the extension of time was granted to him till 01.03.2010. **Annexure IV**

Meanwhile, the consultant M/s.Sound wizard has sent the request to change of the supplier for remaining supply of sound equipments and recommended the following suppliers and details with justification given – copy is enclosed **Annexure V**

.....2

102

99
20
35

Microphones previous option						
Quote from Aditya Infotech						
	Brand	Qty	Model	Specifications	Rate	Price
Gooseneck	Audix	3	Micropod 18HC	M1250 with Flexible gooseneck 18"	Rs.22,125	Rs.66,375
HandHeld Transmitter with Mic	Audix	4	W3-OM5	RAD-360 System with OM5 dynamic transmitter	Rs.44,000	Rs.1,76,000
BodyPack System	Audix	4	W3-BP	RAD-360 Bodypack System with transmitter	Rs.35,750	Rs.1,43,000
MiniMic Headworn	Audix	4	HT5-BG	Slim-line headset vocal condenser	Rs.16,875	Rs.67,500
Lavalier	Audix	4	ADX10	Miniaturized lavalier condenser	Rs.10,875	Rs.43,500
BodyPack System (accessory)	Audix	4	W3-BP	To use HT5 or ADX10 wired	Rs.35,750	Rs.1,43,000
Lavalier Accessories	Audix	4	APS-911	Windscreens	Rs.950	Rs.3,800
Lavalier Accessories	Audix	4	WS10S	Metal Clip	Rs.1,045	Rs.4,180
Lavalier Accessories	Audix	4	MC10L	Battery/Phantom power adapter	Rs.3,750	Rs.15,000
Microphones updated version						
Quote from Sennheiser India						
	Brand	Qty	Model	Specifications	Rate	Price
Gooseneck	Sennheiser	3	MZH 3040	40 cm	Rs.10,000	Rs.30,000
Capsule	Sennheiser	3	ME 34	Cardiod for gooseneck	Rs.7,900	Rs.23,700
Table Stand	Sennheiser	3	MZTX 31	Without Switch	Rs.9,550	Rs.28,650
Windscreens	Sennheiser	3	MZW 36 Pro	For gooseneck	Rs.2,899	Rs.8,697
HandHeld Transmitter with Mic	Sennheiser	3	EW 100-835 G3	Handheld Set	Rs.41,000	Rs.1,23,000
MiniMic Headworn	Sennheiser	6	HSP4	Slim-line headset vocal condenser	Rs.35,500	Rs.2,13,000
Lavalier	Sennheiser	6	Ew 122 G3	Miniaturized lavalier condenser	Rs.41,000	Rs.2,46,000

Speaker system (balance) - previous option						
Quote from Aditya Infotech						
	Brand	Qty	Model	Specifications	Rate	Price
Line Array (H:47/1.20m W:24"/0.60m)	EAW	2	NTL720	500W/500W/500W	Rs.3,35,750	Rs.6,71,500
Flying Cables	EAW	2	KF750	For Subs	Rs.15,250	Rs.30,500
Front Fill Speaker	EAW	4	UB52	150W/8Ω	Rs.64,750	Rs.2,59,000
Speakers down + balcony	EAW	20	VR61	300W/8Ω	Rs.26,750	Rs.5,35,000
Amplifiers	EAW	6	CAZ1400	450W/4Ω	Rs.34,000	Rs.2,04,000

Speaker system (balance) - updated option						
Quote from E&E Systems India						
	Brand	Qty	Model	Specifications	Rate	Price
Line Array (H:47/1.20m W:24"/0.60m)	EAW	2	NTL720	500W/500W/500W	Rs.3,35,750	Rs.6,71,500
Flying Cables	EAW	2	KF750	For Subs	Rs.16,470	Rs.32,940
Front Fill Speaker	EAW	2	UB82	150W/8Ω	Rs.99,360	Rs.1,98,720
Speakers down + balcony	EAW	20	VR61	300W/8Ω	Rs.28,890	Rs.5,77,800
Amplifiers	Mackie	6	CAZ1400	450W/4Ω	Rs.38,727	Rs.2,32,362

103

for SOUND WIZARD
[Signature]
Executive

No. 20, Kothari Road, Nungambakkam, Chennai - 600 034.
Tel : 044- 28261996, 97, 32984914 • E-mail : aditya_chen@adityagroup.com
Website : www.adityagroup.com



BUILDING THE FUTURE

Date: 10/03/2010
Place: Chennai

To,
The Director,
Kalakshetra Foundation,
Thiruvamyur,
Chennai - 600 041

Dear Sir/Madam,

This is with reference to your letter dated February 20, 2010 on the Termination Order of EAW and Audix Products for the Koothambalam upgrading project in Chennai.

We have delivered the below mentioned Goods and have received the Full Payment for the same.

S.No	UNIT	Quantity	Price Per Unit (INR)	VAT (%)	Unit Value excluding VAT
1	EAW NTL 720 Line Array	8	335750.00	12.5	2686000.00
2	EAW NTS22 Subwoofer	2	246625.00	12.5	493250.00
3	EAW FB172 Fly Bar for NTL 720	2	140875.00	12.5	281750.00
Total Value Excluding VAT					3461000.00
Discount (5%) (-)					173050.00
VAT - 12.5% (+)					410993.75
Rounded Off Sales					0.25
GRAND TOTAL					3698944.00

The balance goods could not be delivered due to uncertainty in delivery schedule from the manufacturer's and as informed to us by your consultant, M/S Sound Wizard, they did not have the patience to wait for balance delivery any further.

Kindly acknowledge the receipt of this letter.

Hoping to keep this ongoing business relationship in the future.

For Aditya Infotech Limited

Vishal .B. Joshi
Regional Sales Manager- Professional Audio/Video

109

108

TELERAD

SONY

29/28

146/8, Second Floor, Millenium Towers,
 (Nr. to Mehta Nagar Bus Stop),
 Nelson Manickam Road, Chennai - 600 029.
 Telefax : 23744883, 23745359 / 60, 43553070
 Email : teleradchennai@airtelmail.in
 www.teleradindia.com

FINAL OFFER

TO

M/S Kalakshetra foundation,
 Chennai.

Authorised Distributer for
 Sennheiser Electronics India Pvt. Ltd.,
 39-42B, Edmonton Shopping Mall,
 Hotel Bristol, M.G. Road, Gurgaon
 Haryana - 122 002.

Our Ref. No.: TEL/CHN/212/SENN/O9-10/INR Dt.:27/02/2010

S.NO.	MODEL	DESCRIPTIONS	QTY	UNIT PRICE IN INR	TOTAL PRICE IN INR
1	MZH 3040	GOOSENECK FOR ME INSTALLED	3	10,300.00	30,900.00
2	ME 34	CONDENSER MIC	3	8,137.00	24,411.00
3	MZTX 31	TABLE STAND	3	9,836.00	29,508.00
4	MZW 36 PRO	WINDSHIELD	3	2,986.00	8,958.00
5	EW 135 G3	VOCAL SET	3	42,230.00	126,690.00
6	EW 122 G3	PRESENTATION SET	6	42,230.00	253,380.00
7	HSP EW 4	HEADSET MICROPHONE BLACK	6	36,565.00	219,390.00
					693,237.00

Terms and Conditions:

- 1 DELIVERY :With in 10days from the date of receipt of your confirmed order.
- 2 PAYMENT :50% Advance and Balance Against delivery
- 3 TAXES :VAT 4 % Will be Extra.
- 4 VALIDITY :1 Month
- 6 ORDER IN FAVOUR OF : M/S TELERAD,CHENNAI.
- 7 WARRANTY :Two Years from the date of Invoice
- 8 BILLING :From TELERAD,CHENNAI.

For TELERAD

 T.P.KUMAR
 AREA MANAGER



AREA CODE: 079
 TIN: 33671463744
 C.S.T NO.: 867223/01/04/2006

6,93,237 -

4,1,230 -

105

Authorised Agents for **SONY** Professional Video Systems

A DIVISION OF AMBALAL SARABHAI ENTERPRISES LTD., REGD. OFFICE : WADI WADI, VADHODHARA - 309 007



Sasi Enterprises

"Nelson Plaza", New No.90, (149), Nelson Manickam Road, Choolaimedu, Chennai - 600 094.

Telefax : 91-44-23746661, 23746761, 23743769

E-mail : dhayalvr@vsnl.com/ dhayalvr@eth.net

BOSCH

Security
Certified Partner

AUTHORISED : BOSCH SYSTEM INTEGRATOR FOR COMMUNICATION, CCTV, FIRE ALARM,
ACCESS CONTROL SYSTEMS & TELEX COMMUNICATION PRODUCT.

TO
M/s. Kalakshetra Foundation ,
Kalakshetra Road, Thiruvanmiyur,
Chennai - 600 041.
Ph: 24521169, 0836, 4057
Email : works@kalakshetra.in

NO:SE/Q/KF/9661

Dt: 01.03.2010

Kind Attn : Mr. Srinivasan

Dear Sir,

Sub : Offer for Supply of Sennheiser Make Wireless Microphone System for Kalakshetra - Reg.

With reference to the above subject. Accordingly we pleased to submitting our offer details given below

Sl.No.	Type	Description	Qty	U / Rate	Amount
1	MZH 3040	Gooseneck for ME Installed	3	10,500	31,500
2	ME 34	Condenser Mic	3	8,295	24,885
3	MZTX 31	Table Stand	3	10,027	30,081
4	MZW 36 PRO	Windsheild	3	3,044	9,132
5	EW 135 G3	Vocal Set	3	43,050	129,150
6	EW 122 G3	Presentation Set	6	43,050	258,300
7	HSP EW 4	Headset Microphone Black	6	37,275	223,650
Total					706,698

(Rupees Seven Lakhs Six Thousand Six Hundred and Ninety Eight Only)

Our Terms and Conditions:-

Validity : Our offer is valid till 30 Days from date of this Offer.

Prices : Prices quoted by us are Exclusive of VAT @4% will be charged extra.

Delivery : Within 10 days after receipt of your confirmed order.

Payment : 50% Advance payment along with P.O. Balance 50% before delivery of the materials.

Guarantee : Twelve months from date of supply against manufacturing defects only.

Thanking you and assuring you of our best services always.

Yours faithfully,
For SASI ENTERPRISES.

R. BALARAMAN
PROPRIETOR

7,06,698

4% VAT

28,268

7,34,966

100

BOSCH
Security System

Electro-Voice®
P R O S O U N D

DYNACORD®
P R O M U S I C & C O N C E R T S O U N D

NEUMANN.BERLIN
THE MICROPHONE COMPANY

SENNHEISER
Wireless and Wired Microphone

110

31/08



Sennheiser Electronics India Private Limited
39-12B Edmonton Shopping Mall, Hotel Bristol, M G Road,
Gurgaon, Haryana 122002 India
Phone: +91 124 4187800 Fax: +91 124 4187830
www.sennheiser.com

Sennheiser Price Quote

FOR ACCOUNTS AND RISK OF:
Ms Leela Samson
Kalakshetra Foundation
Chennai

CONSIGNEE:
Ms Leela Samson
Kalakshetra Foundation
Chennai

Please find the pricing for Sennheiser microphones as per your requirements.

Sr.no.	Description	Quantity	Unit Price (INR)	Total (INR)
1	Sennheiser MZH 3040 metal gooseneck	3	10,000.00	30,000.00
2	Sennheiser ME 34 condenser capsule	3	7,900.00	23,700.00
3	Sennheiser MZTX 31 table stand	3	9,550.00	28,650.00
4	Sennheiser MZW 36 Pro	3	2,899.00	8,697.00
4	Sennheiser 100-835 G3 handheld wireless set	3	41,000.00	123,000.00
5	Sennheiser ew 122 G3 lapel wireless set	6	41,000.00	246,000.00
6	HSP 4 ew headworn microphone	6	35,500.00	213,000.00
TOTAL			Grand Total	673,047.00

Terms & Conditions

1. Terms of payment - 100% advance payment to be made at the time of placing the order on particular distributor.
2. Terms of Delivery - F.O.R.
3. Taxes - Inclusive of all taxes (VAT @5%)
4. Transit Insurance / Freight - Inclusive in price.
5. Road Permit - If required, shall be arranged by Consignee.
6. Octroi / Entry tax - Price excludes Octroi which shall be paid at actuals by Cheque drawn in favour of the authorities prior to despatch of material.

Delivery Schedule

Minimum Delivery time period 25 days from the date of receipt of confirmed Purchase order alongwith Payment

Warranty & Support Terms

Two years warranty

Thanking you

For Sennheiser India Pvt Ltd

Naveen Sridhar
Sales manager-Professional segment
Sennheiser Electronics India Pvt Ltd

6,73,047

VAT - Inclusive
Freight Inclusive
Delivery cycle at actual

125
107

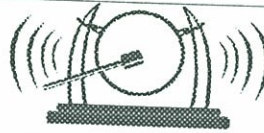

Resonators

Date:03/03/2010.

CST & Tin No:29840481834.

Proforma Invoice

RefNo :02.03/03/2010

Kind Attn: Ms. Leela Samson
KALAKSHETRA Foundation
Thirruvanmiyur
Chennai 600041.

Your Sales Tax Nos:

Kindly Attend:PO For Veena Varuni Project.

Contact no: +91 9880535569 - 9845135569

SL.NO	PARTICULARS	Qty	Unit Price	Value
01	UB82e Black / The UB82e has a compact vented rectangular enclosure and is engineered to provide very high output and wideband response in distributed applications.	02	106,315	212,630
02	KF750/KF755 Spare Fly Clip/Cables [FC700C]	02	17,623	35,246
03	Mackie FRS 1700 / 1660W Professional Lightweight Stereo Power Amplifier	06	41,825	250,950
04	VR61 Black / The VR61 compact full-range loudspeaker offers a specially engineered, purpose-designed 6-inch LF driver that enables it to match the output of competitive 8-inch 2-way designs.	20	36,912	738,240
05	NTL720 Black 230 VAC / A true three-way design delivering big-time performance with maximized vocal clarity. Next, the entire enclosure face is filled by a full-sized mid/high horn providing 110-degree (horizontal) by 12-degree (vertical) dispersion.	02	359,253	718,506

All payments requested by "Account payee" instruments only

Sub Total:
Vat @ 12.5%
Grand Total

1,955,572.00
244,447.00
2,200,019.00

(Twenty Two Lakh & Nineteen Only)

For Resonators,

Srinivas
A.P.Srinivas

Terms & Condition :

Payment as 100 % advance DD against Delivery .
Freight and Freight insurance will be additional at actual .
Delivery immediate if in stock or 4 - 8 weeks from the date of Confirmed order along with 50 % advance .
Proforma Invoice is valid for 30 days .

905/37,4th Main, 3rd Cross, Vidydranyapuram, Mysore-570008, Karnataka, INDIA.
Ph : (0821) 2482113 , 2481679. Mobile : 9880535569 , 9845135569.
Email : srinirec@hotmail.com , fluteprasad@rediffmail.com

108

103

24
/38

Q
6/3
AD
CP 6/3

Date: 03/03/2010

To,
Kalakshetra Foundation,
Thiruvanmiyur,
Chennai-600041.

Kind Attn: Ms Leela Samson

Sub: Supply of Audio Equipment .

Please find enclosed herewith the Pro Forma Invoice for the Audio Equipment as per your requirement.

Freight will be extra at actual.

Delivery : 6-8 weeks from receipt of Confirmed order.

Payment Terms: 100% advanced against delivery.

Validity : Proforma Invoice valid for 30 days.

For Resonators.

Srinivas

Authorized Signatory.

109



E&E SYSTEMS

E&E Systems (India) Pvt. Ltd.

#14 Bhattrahalli, Old Madras Road, Near Garden City College,
K.R Puram, Bangalore-560049, INDIA.

Proforma Invoice

TIN No: 29830841467 Dated 29.04.2009

Service Tax No: AACCE1438RST001

Billing Adress:
Kind Attn: Ms. Leela Samson
KALAKSHETRA Foundation
Thirruvanmiyur
Chennai 600041

PI No : 002/Kala/04.02.2010
Date : 04.02.2010

Ph No.- 044-24524359
Email : info@kalakshetra.in

Your Po No :
Date :

Sl.No	Model / Description	Qty	Unit Price	Total
1	UB82e Black / The UB82e has a compact vented rectangular enclosure and is engineered to provide very high output and wideband response in distributed applications.	2	99,360	198,720
2	KF750/KF755 Spare Fly Clip/Cables [FC700C]	2	16,470	32,940
3	Mackie FRS 1700 / 1660W Professional Lightweight Stereo Power Amplifier	6	38,727	232,362
4	VR61 Black / The VR61 compact full-range loudspeaker offers a specially engineered, purpose-designed 6-inch LF driver that enables it to match the output of competitive 8-inch 2-way designs.	20	28,890	577,800
5	NTL720 Black 230 VAC / A true three-way design delivering big-time performance with maximized vocal clarity. Next, the entire enclosure face is filled by a full-sized mid/high horn providing 110-degree (horizontal) by 12-degree (vertical) dispersion.	2	335,750	671,500

Amount in words : Nineteen Lakh Twenty Seven Thousand Four Hundred and Eighty Eight Only.

Sub Total :	1,713,322.00
Add Tax @ 12.5%	214,166.00
Grand Total :	1,927,488.00

Terms & Condition :

Payment as 100 % advance DD against Delivery .
Freight and Freight insurance will be additional at actual .
Delivery immediate if in stock or 4 - 8 weeks from the date of
Confirmed order along with 50 % advance .
Proforma Invoice is valid for 30 days .

For E & E Systems Indian Pvt.Ltd.
[Signature]



E&E Systems (India) Pvt Ltd

Regd. Off. : 82/83, Borewell Road, Whitefields
Bangalore - 560 066, India
Tel. : +91 (0) 80 41743030
Fax : +91 (0) 80 28456467

110

AD/EO
CD 22/2

105



E&E SYSTEMS

Date: 19/02/2010

To,

Kind Attn: Ms. Leela Samson

Kalakshetra Foundation.

Thiruvananthapuram,

Chennai - 600041.

Sub: Supply of Audio Equipment .

Please find enclosed herewith the Pro Forma Invoice for the Audio Equipment for Kalakshetra .

Delivery Time - 6 weeks.

Payment Terms - payment to be made on delivery.

Kindly acknowledge receipt of the letter.

For E & E Systems (India) Pvt Ltd.

Shyam Suresh

Shyam Suresh

Sales/Project Engineer



111

E&E Systems (India) Pvt Ltd

Regd. Off. : 82/83, Borewell Road, Whitefields

Bangalore - 560 066, India

Tel. : +91 (0) 80 41743030

Fax : +91 (0) 80 28456467

41903030

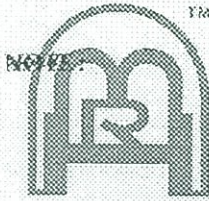

106

21/28

MRH DIGITAL SYSTEMS™ PRIVATE LIMITED

Skanda Krupa, No. 191, 1st Cross, 38th Main, BOOHBCS,
BTM Hind Stage, Bangalore - 560 068, INDIA.
Phone : (91-80) 4120 0571/72/73, Fax : (91-80) 4120 0574

TO
KALAKSHETRA FOUNDATION
THIRUVANMIYUR
CHENNAI - 600041

DATE:02.03.10

KIND ATTN: MS. LEELA SAMSON

QUOTATION

SL NO.	MODEL/DESCRIPTION	UNIT RATE	QTY.	AMOUNT
1	UB82e Black / The UB82e has a compact vented rectangular enclosure and is engineered to provide very high output and wideband response in distributed applications.	104,328.00	2	208,656.00
2	KF750/KF755 Spare Fly Clip/Cables [FC700C]	17,294.00	2	34,588.00
3	Mackie FRS 1700/1660W Professional Lightweight Stereo Power Amplifier	40,663.00	6	243,978.00
4	VR61 Black / The VR61 compact full-range loudspeaker offers a specially engineered, purpose-designed 6-inch LF driver that enables it to match the output of competitive 8-inch 2-way designs.	30,335.00	20	606,700.00
5	NTL720 Black 230 VAC / A true three-way design delivering big-time performance with maximized vocal clarity. Next, the entire enclosure face is filled by a full-sized mid/high horn providing 110-degree (horizontal) by 12-degree (vertical) dispersion.	352,538.00	2	705,076.00
TOTAL				1,798,998.00
SALES TAX @ 12.5%				224,874.75
GRAND TOTAL				2,023,872.75

NOTE :

1. FREIGHT WILL BE EXTRA AT ACTUALS.
2. DELIVERY : 8-10 WEEKS FROM RECEIPT OF COMMERCIALY CLEAR PURCHASE ORDER
3. PAYMENT TERMS :100% ADVANCE WITH PURCHASE ORDER.
4. VALIDITY: 30 DAYS

FOR MRH DIGITAL SYSTEMS PVT. LTD.

T.S.SRIRAM
BUSINESS HEAD -- SOUTH
Mobile : 93417 33603

112

107
CD
6/5 A0/80
CD 6/3

28/28

Date: 04/03/2010

To,
Kind Attn: Ms Leela Samson
Kalakshetra Foundation,
Thiruvannamipur,
Chennai-600041.

Sub: Supply of Audio Equipment .

Please find enclosed herewith the Pro Forma Invoice for the Audio Equipment as per your requirement.

Freight will be extra at actual.

Delivery : 8-10 weeks from receipt of commercially clear Purchase Order.

Payment Terms: 100% advance with purchase order.

Validity :30 days.

Kindly acknowledge receipt of the letter.

For MRH Digital Systems Pvt Ltd.

Authorized Signatory.

113

SOUND WIZARD also approved the difference of old supplier, specification /brand and change of supplier name and offer value as per the information below:

21/28

Approval /obtained/brand to be supplied value	Change of the supplier and Brand and value as suggested	Difference
Aditya Infotech Microphone--Rs.6,88,849 5%discount 34,442 - 6,54,407	M/s.Sennheiser/India Microphone Rs. 6, 73,047	(+)18,640
Aditya Infotech Balance items -Rs.19,12,500 5% Discount - 95,625 - 18,16,875	M/s.E & E Systems India Speaker systemRs.19,27,487	(+)1,10,612
Total 24,71,282	26,00,534	(+) 1,29,252

For SOUND WIZARD

 Executive
 Didier Weiss

114

101

2/2/08

Sound Wizard

Acoustics & Pro-audio

REPORT dated 9/03/2010

To: Kalakshetra Foundation

Re: Supplier final recommendation for your
auditorium equipment balance purchase

Pages: 2

For supplying of microphones (balance) updated version

Sl.No.	Name of the suppliers	Quoted value	Position	Total cost to be awarded-L1
1	M/s.Sennheiser India Pvt Ltd	Rs.6,73,047/-	L 1	Rs.6,73,047/
2	M/s.Sasi Enterprises	Rs7,34,966/-	L 2	
3	M/s.Telerad	Rs.7,20,967/-	L 3	

SOUND WIZARD approved and recommended the M/s.Senneiser India Pvt ltd, brand and specification and requested to place the supply order on them, at a total cost of Rs.6, 73,047/-

For supplying of speaker (balance) updated version:

Sl.No.	Name of the suppliers	Quoted value	Position	Total cost to be awarded-L1
1	M/s.E & E systems /Bangalore	Rs.19,27,488/-	L 1	Rs.19,27,488/ Freight and Insurance will be additional at actual.
2	M/s.MRH Digital systems pvt ltd, Mumbai	Rs20,23,878-	L 2	
3	M/s.Resonaltors Bangalore	Rs22,00,019/-	L 3	

SOUND WIZARD approved and recommended the M/s.E& E systems /Bangalore, brand and specification and requested to place the supply order on them, at a total cost of Rs.19,27,488/-

for SOUND WIZARD

Executive

SOUND WIZARD – Acoustics and Pro-Audio

Shakti, Auroville - 605 101, Tamil Nadu, India / Tel: +91 (0) 413 262 26 59 Fax: 262 34 10

Email: info@soundwizard.net Web site: www.soundwizard.net

115

E.O
20/2/10

प्राप्ति स्वीकृति (रसीद) **ACKNOWLEDGEMENT**

* एक रजिस्ट्री पत्र/पोस्टकार्ड/पैकेट/पार्सल प्राप्त हुआ
बीमा Registered

* Received a Insured Letter/Postcard/Packet/Parcel

पाने वाले का नाम
Addressed to (Name)

M/S Aditya Infotech Limited, No. 20
Kokhar Road, Nungambakkam,
Chennai - 600034

† बीमा का मूल्य (रुपयों में)

† Insured for Rupees

वितरण की तारीख / Date of delivery

- * अनावश्यक को काट दिया जाए।
- * Score out the matter not required.
- † केवल बीमा वस्तुओं के लिए।
- † For Insured articles only



पाने वाले के हस्ताक्षर / Signature of addressee

[Handwritten signature]
20/2/10
11-10-10

24/2/10

116

4.	EAW VR61 Front Fill Speaker	20
5.	EAW CAZ 1400 Amplifier	6
6.	Audix Micro pod 18HC Gooseneck Microphone	3
7.	Audix W3-OM5 Handheld Transmitter with Mic	4
8.	Audix W3-BP Body Pack System	4
9.	Audix HT5-BG Slim Line Headphone Microphone	4
10.	Audix ADX 10-P Lavalier Microphone	4
11.	Audix W3-BP Body Pack System	4
12.	Audix APS-911 Battery Phantom Power Adapter	4
13.	Audix WS10S External Wind Screen	4
14.	Audix MC 10L Metal Clip	4

Based on the recommendation given by our consultant M/s.Sound Wizard, all the materials should be delivered in all respects by 20.12.2009 as per the supply order and delivered only part materials.

Due to uncertainty in delivery schedule and the changing of your status as the official distributor in for the Indian market we must cancel all pending deliveries of materials under the above mentioned supply order . All the balance equipment under the above mentioned supply order is to be terminated with immediate effect.

Kindly acknowledge the receipt of the letter and confirm termination of the balance equipment.



Leela Samson
Director

114

35/28

ANNEXURE IV

o/c

RPAD

C:\ 2009-2010\V.Admin\2. Engineering\i.Plan\d.Sound systems\koothambalam.doc	February 20, 2010
--	-------------------

M/s. Aditya InfoTech Limited,
 No, 20 Kothari Road,
 Nungambakkam,
 Chennai 600 034.

Sir(s)

Sub: Supply of EAW & Audix Products – Termination of Supply order - Reg

Ref: Your offer No. AIL / CHN / 1409 / 001 dated 14.09.2009
 Your letter dated 07.11.2009
 Your letter dated 10.11.2009

Our supply order No. C\2009-2010\V.Admin\2.Engineering\i.Plan\d.Sound systems
 \koothambalam.doc dated 09 November 2009.

Recommendation from the consultant M/s.Sound Wizard

Following our supply order cited above, you have delivered some of the goods as listed. We thank you for this delivery.

Delivered and paid:

Sl. No.	Unit	Qty in Nos
1	EAW NTL 720 Line Array	8
2.	EAW NTS22 Subwoofer	2
3.	EAW FB172 Fly Bar for NTL 720	2

Remaining as per the supply order:

Sl. No.	Unit	Qty in Nos.
1	EAW NTL 720 Line Array	2
2.	EAW KF 750 Cables - FC700C	2
3.	EAW UB52i Loudspeaker	4

(118)

115

36
38

- 3 -

Approval /obtained/brand to be supplied value	Change of the supplier and Brand and value as suggested	Difference In cost
EAW products	M/s.Sennheiser/India	
Microphone--- Rs.6,88,849		
5% discount 34,442 -		
6,54,407	Micro phone -- Rs. 6, 73,047	(+) 18,640
Speaker system	M/s.E & E Systems India	
Balance items -Rs.19,12,500		
5% Discount - 95,625 -		
18,16,875	Speaker systemRs.19,27,488	(+)1,10,613
Total 24,71,282	26,00,535	+1,29,253

Based on M/s.Aditya info tech pvt ltd reply letter and in view of urgency / concurrence of the consultant, the supply order for above two agencies may be issued to complete in time.

Based on the letter we received from M/s.Aditya InfoTech pvt ltd, we may write a letter to him stating that the extra amount incurred due to his non-supply of materials will have to be borne by him.

Re-submitted for approval of change of the supplier to M/s.Sennheiser /India for Microphone supply order for the value of Rs.6, 73,047/- and M/s.E & E Systems India for Speaker systems for Rs.19, 27,488/- please.

Arula Samra
DIRECTOR
19/3 2010

Madhu Madyal

P.T. Krishnan
24/03/10
P.T.KRISHNAN

119

For supplying of Micro phones, the received quotes from suppliers, details and comparative statement (placed below) **Annexure VIII**

Sl. No.	Name of the suppliers	Quoted value	Position	Total cost to be awarded-L1
1	M/s.Sennheiser India Pvt Ltd	Rs.6,73,047/-	L 1	Rs.6,73,047/
2	M/s.Sasi Enterprises	Rs7,34,966/-	L 2	
3	M/s.Telerad	Rs.7,20,967/-	L 3	

The consultant approved and recommended the M/s.Senheiser India Pvt ltd, brand and specification and requested to place the supply order on them, at a total cost of Rs.6, 73,047/- **Annexure X**

For supplying of speaker (balance) updated version, the received quotes from suppliers and details, (placed below) **Annexure IX**

Sl. No.	Name of the suppliers	Quoted value	Position	Total cost to be awarded-L1
1	M/s.E & E systems /Bangalore	Rs.19,27,488/	L 1	Rs.19, 27,488/Freight and Insurance will be additional at actual.
2	M/s.MRH Digital systems pvt ltd, Mumbai	Rs20,23,878-	L 2	
3	M/s.Resonaltors Bangalore	Rs22,00,019/-	L 3	

The consultant approved and recommended the M/s.E& E systems /Bangalore, brand and specification and requested to place the supply order on them, at a total cost of Rs.19, 27,488/- **Annexure X**

The details of difference between old supplier, specification /brand and Revised selected model, brand and change of supplier name and their offer value and difference in cost for old supplier and present are tabulated below. 3



C:\ 2009-2010\V.Admin\2. Engineering\i.Plan\Sound equipments .doc	March 18, 2010
---	----------------

Sub: **Note – Re-Submission** - Koothambalam – Sound equipments - EAW
 And Audix products – **Change of suppliers** – Approval of - Reg.

Ref: Approval dated 6.11.2009 (placed below please)

Remarks pointed out in the note dated 18.2.2010 by Sri.P.T.Krishnan

In continuation to the office note as cited in the above reference, and in tune with the advice contained in the remarks , the following steps have been taken and resubmitted for approval.

- The termination of contract / Supply order, was issued to the agency M/s.Aditya info Tech Limited, Nungambakkam, based on the recommendation / remarks given by the consultant M/s.Sound wizard. The receipt of the letter of termination of supply order (Balance materials) was received from the postal acknowledgement on 29.12.2010. **Annexure VI**
- Further, the reason for Non-supply of the balance materials as per the work order from M/s.Aditya InfoTech ltd has been received. **Annexure VII**
- Since the model, specification of the equipment has been changed/selected by the consultant M/s.sound wizard, further quote from the M/s.Aditya InfoTech ltd, was not appraised by the consultant.
- The fresh quotations for the supplying balance sound equipments (as per the list) as per the selected models and changed specifications equipments were called by the consultant from various manufactures and brand, and the quotes were received by the Foundation as directed.

..... 2

121

114



E&E SYSTEMS

E&E Systems (India) Pvt. Ltd.

#14 Bhattrahalli, Old Madras Road, Near Garden City College,
K.R Puram, Bangalore-560049, INDIA.

Proforma Invoice

TIN No: 29830841467 Dated 29.04.2009

Service Tax No: AACCE1438RST001

Billing Address:

Kind Attn: Ms. Leela Samson
KALAKSHETRA Foundation
Thirruvanmiyur
Chennai 600041

PI No : 002/Kala/04.02.2010

Date : 04.02.2010

Ph No.- 044-24524359

Email : info@kalakshetra.in

Your Po No :

Date :

Sl.No	Model / Description	Qty	Unit Price	Total
1	UB82e Black / The UB82e has a compact vented rectangular enclosure and is engineered to provide very high output and wideband response in distributed applications.	2	99,360	198,720
2	KF750/KF755 Spare Fly Clip/Cables [FC700C]	2	16,470	32,940
3	Mackie FRS 1700 / 1660W Professional Lightweight Stereo Power Amplifier	6	38,727	232,362
4	VR61 Black / The VR61 compact full-range loudspeaker offers a specially engineered, purpose-designed 6-inch LF driver that enables it to match the output of competitive 8-inch 2-way designs.	20	28,890	577,800
5	NTL720 Black 230 VAC / A true three-way design delivering big-time performance with maximized vocal clarity. Next, the entire enclosure face is filled by a full-sized mid/high horn providing 110-degree (horizontal) by 12-degree (vertical) dispersion.	2	335,750	671,500

Amount in words : Nineteen Lakh Twenty Seven Thousand Four Hundred and Eighty Eight Only.

Sub Total : 1,713,322.00

Add Tax @ 12.5% 214,166.00

Grand Total : 1,927,488.00

Terms & Condition :

Payment as 100 % advance DD against Delivery .
Freight and Freight insurance will be additional at actual .
Delivery immediate if in stock or 4 - 8 weeks from the date of
Confirmed order along with 50 % advance .
Proforma Invoice is valid for 30 days .

For E & E Systems Indian Pvt.Ltd.

Shyam



E&E Systems (India) Pvt Ltd

Regd. Off. : 82/83, Borewell Road, Whitefields

Bangalore - 560 066, India

Tel. : +91 (0) 80 41743030

Fax : +91 (0) 80 28456467

122

AD/EO
22/2



E&E SYSTEMS

Date: 19/02/2010

To,

Kind Attn: Ms. Leela Samson

Kalakshetra Foundation.

Thiruvannamipur,

Chennai – 600041.

Sub: Supply of Audio Equipment .

Please find enclosed herewith the Pro Forma Invoice for the Audio Equipment for Kalakshetra .

Delivery Time - 6 weeks.

Payment Terms - payment to be made on delivery.

Kindly acknowledge receipt of the letter.

For E & E Systems (India) Pvt Ltd.

Shyam

Shyam Suresh

Sales/Project Engineer



23

E&E Systems (India) Pvt Ltd

Regd. Off. : 82/83, Borewell Road, Whitefields

Bangalore - 560 066, India

Tel. : +91 (0) 80 41743030

Fax : +91 (0) 80 28456467



120

ANNEXURE

Sl. No.	Model/ Description	Qty.	Unit price	Total
1.	UB82e Black/the UB82 has a compact vented rectangular enclosure and is engineered to provide very high output and wideband response in distributed applications.	2 ✓	99,360 ✓	1,98,720 ✓
2.	KF750/KF755 Spare Fly Clip/Cables (FC700C)	2 ✓	16,470 ✓	32,940 ✓
3.	Mackie FRS 1700 / 1660W Professional Lightweight Stereo Power Amplifier	6 ✓	38,727 ✓	2,32,362 ✓
4.	VR61 Black/The VR61 compact full-range loudspeaker offers a specially engineered, purpose-designed 6-inch LF driver that enables it to match the output of competitive 8-inch 2-way designs	20 ✓	28,890 ✓	5,77,800 ✓
5.	NTL720 Black 230 VAC / A true three-way deign delivering big time performance with maximized vocal clarity. Next, the entire enclosure face is filled by a full-sized mid/high horn providing 110-degree (horizontal) by 12-degree (vertical) dispersion	2 ✓	3,35,750 ✓	6,71,500 ✓
(Rupees nineteen lakhs twenty seven thousand four hundred and eighty eight only)		Sub Total:		17,13,322
		Add Tax @ 12.5%		2,14,166
		Grand Total :		19,27,488

To

E & E Systems (India) Pvt. Ltd.,
#14, Bhattrahalli, Old Madras Road,
Near Garden City College,
K.R. Puram, Bangalore-560 049,
India.

129
111

DRAFT

C:\ 2009-2010\V.Admin\2. Engineering\i.Plan\d.Sound systems\koothambalam.doc	March 24, 2010
--	----------------

M/s. E & E Systems (India) Pvt Ltd,
 # 14, Bhattrahalli, Old Madras Road,
 Near Garden City College,
 K.R.Puram,
 Bangalore 560 049,India.

Sub: Supplying of Audio Equipments – Kalakshetra Foundation -Supply order - Reg.
 Ref: Your offer No.Pl.No:002/Kala/04.02.2010 dated 04.02.2010

Based on the recommendation given by the consultant M/s.Sound Wizard, approved by the works committee, The Director, Kalakshetra Foundation is pleased to award the supply order for Supplying of Audio equipments at a total cost of Rs. 19, 27,488/- (Rupees Nineteen lakhs twenty seven thousand four hundred and eighty eight only), as per the Annexure specification, terms and condition, enclosed herewith in all respects. This is a firm rate contract. General term and conditions applicable to this order is attached.

The payment will be disbursed after the material is approved and certified by the consultant - M/s.Sound wizard with in a week.

Delivery time – 4 to 6 weeks from the date of supply order till 30.04.2010.
 Warrant as specified in the conditions

The materials should be delivered at our premises (door delivery) and materials should be covered with Insurance up to Kalakshetra Foundation/Chennai. Freight and Freight insurance will be additional at actual will be paid producing the bills.

The material delivered should be in original packing WITHOUT tampering with the original manufacturer’s packing and in good condition.

The above supply order should be effected and completed in all respects by 30.04.2010. If the progress of the supply is found to be not satisfactory or the total supply is not completed in all respects as per the schedule as mentioned above, this supply order will automatically cease without notice and without assigning any reason.

Your acceptance of the conditions as indicated above may please be intimated to us within one week after the receipt of this letter by email.

Kindly acknowledge receipt of the letter.

Leela Samson
 Director

One more to placed
 below signature
 please,

For Approval



CAJ

 DIRECTOR

(215)



रसो वै सः

122

Kalakshetra
F O U N D A T I O N

C:\ 2009-2010\V.Admin\2. Engineering\i.Plan\d.Sound systems\koothambalam.doc

March 24, 2010

M/s. E & E Systems (India) Pvt Ltd,
14, BhattraHalli, Old Madras Road,
Near Garden City College,
K.R.Puram,
Bangalore 560 049,India.

Sub: Supplying of Audio Equipments – Kalakshetra Foundation -Supply order - Reg.
Ref: Your offer No.Pl.No:002/Kala/04.02.2010 dated 04.02.2010

Based on the recommendation given by the consultant M/s.Sound Wizard, approved by the works committee, The Director, Kalakshetra Foundation is pleased to award the supply order for Supplying of Audio equipments at a total cost of Rs. 19, 27,488/- (Rupees Nineteen lakhs twenty seven thousand four hundred and eighty eight only) inclusive of VAT, as per the Annexure specification, terms and condition, enclosed herewith in all respects. This is a firm rate contract. General term and conditions applicable to this order is attached.

The payment will be disbursed after the material is approved and certified by the consultant - M/s.Sound wizard with in a week.

Delivery time – 4 to 6 weeks from the date of supply order till 30.04.2010.
Warrant as specified in the conditions

The materials should be delivered at our premises (door delivery) and materials should be covered with Insurance up to Kalakshetra Foundation/Chennai. Freight and Freight insurance will be additional at actual will be paid producing the bills.

The material delivered should be in original packing WITHOUT tampering with the original manufacturer's packing and in good condition.

The above supply order should be effected and completed in all respects by 30.04.2010. If the progress of the supply is found to be not satisfactory or the total supply is not completed in all respects as per the schedule as mentioned above, this supply order will automatically cease without notice and without assigning any reason.

Your acceptance of the conditions as indicated above may please be intimated to us within one week after the receipt of this letter by email.

Kindly acknowledge receipt of the letter.

Leela Samson
Director

126

Founder : Smt. Rukmini Devi Chairman : Justice Sri S. Mohan Former Judge Supreme Court
Director : Ms Leela Samson Member Secretary : Sri R.V. Ramani Governing Board

Kalakshetra Foundation Thiruvanniyur Chennai 600 041
Tel: 0091-(0)44-2452 0836 / 4057 / 1844 Fax : 0091-(0)44-2452 4359
Email : info@kalakshetra.in Website : www.kalakshetra.in

123



Sennheiser Electronics India Private Limited
39-12B Edmonton Shopping Mall, Hotel Bristol, M G Road,
Gurgaon, Haryana 122002 India
Phone: +91 124 4187800 Fax: +91 124 4187830
www.sennheiser.com

Sennheiser Price Quote

FOR ACCOUNTS AND RISK OF:
Ms Leela Samson
Kalakshetra Foundation
Chennai

CONSIGNEE:
Ms Leela Samson
Kalakshetra Foundation
Chennai

Please find the pricing for Sennheiser microphones as per your requirements.

Sr.no.	Description	Quantity	Unit Price (INR)	Total (INR)
1	Sennheiser MZH 3040 metal gooseneck	3	10,000.00	30,000.00
2	Sennheiser ME 34 condenser capsule	3	7,900.00	23,700.00
3	Sennheiser MZTX 31 table stand	3	9,550.00	28,650.00
4	Sennheiser MZW 36 Pro	3	2,899.00	8,697.00
4	Sennheiser 100-835 G3 handheld wireless set	3	41,000.00	123,000.00
5	Sennheiser ew 122 G3 lapel wireless set	6	41,000.00	246,000.00
6	HSP 4 ew headworn microphone	6	35,500.00	213,000.00
			Grand Total	673,047.00
TOTAL				

Terms & Conditions

1. Terms of payment - 100% advance payment to be made at the time of placing the order on particular distributor.
2. Terms of Delivery - F.O.R.
3. Taxes - Inclusive of all taxes (VAT @5%)
Transit Insurance / Frieght - Inclusive in price.
5. Road Permit - If required, shall be arranged by Consignee.
6. Octroi / Entry tax - Price excludes Octroi which shall be paid at actuals by Cheque drawn in favour of the authorities prior to despatch of material.

Delivery Schedule

Minimum Delivery time period 25 days from the date of receipt of confirmed Purchase order alongwith Payment

Warranty & Support Terms

Two years warranty

Thanking you

For Sennheiser India Pvt Ltd

B. Sridhar
Naveen Sridhar
Sales manager-Professional segment
Sennheiser Electronics India Pvt Ltd

*Received in
Amount PO dt 24.1.10*

6,73,047 -

VAT - Inclusive

Frieght Inclusive

Delivery chge at actual -

127
108



ANNEXURE

Sl. No.	Description	Qty.	Unit price (INR)	Total (INR)
1.	Sennheiser MZH 3040 metal gooseneck	3	10,000-00	30,000-00
2.	Sennheiser ME 34 condenser capsule	3	7,900-00	23,700-00
3.	Sennheiser MZTX 31 table stand	3	9,550-00	28,650-00
4.	Sennheiser MZW 36 Pro	3	2,899-00	8,697-00
5.	Sennheiser 100-835 G3 handheld wireless set	3	41,000-00	1,23,000-00
6.	Sennheiser ew 122 G3 lapel wireless set	6	41,000-00	2,46,000-00
7.	HSP 4 ew headworn microphone	6	35,500-00	2,13,000-00
	Total			6,73,047-00

(Rupees six lakhs seventy three thousand and forty seven only)

Terms & Conditions:

1. Rate inclusive of VAT, Transit insurance & Freight
2. Rate excludes Octroi/Entry tax which will be paid at actual

To

M/s. Sennheiser Electronic India Private Ltd.,
39-42B, Edmonton Shopping Mall,
Hotel Bristol, M.G. Raod,
Gurgaon, Haryana-122 002,
India.

125

DRAFT

C:\ 2009-2010\V.Admin\2. Engineering\i.Plan\d.Sound systems\koothambalam.doc	March 24, 2010
--	----------------

M/s. Sennheiser Electronics India Private limited,
 39-42B Edmonton Shopping Mall, Hotel Bristol,
 M.G.Road, Gurgaon,
 Hariyana 122 002, India.

Sub: Supplying of Audio Equipments/Micro phones – Kalakshetra Foundation -Supply Order - Reg.
 Ref: Your offer dated Nil

Based on the recommendation given by the consultant M/s.Sound Wizard, approved by the works committee, The Director, Kalakshetra Foundation is pleased to award the supply order for Supplying of Audio equipments/Micro phones at a total cost of Rs. 6, 73,047/- (Rupees Six Lakh seventy three thousand forty seven only), as per the Annexure specification, terms and condition, enclosed herewith in all respects. This is a firm rate contract. General term and conditions applicable to this order is attached. The rate inclusive of VAT, Transit Insurance/Freight and excludes Octroi / Entry tax excludes and will be paid at actual.

The payment will be disbursed after the material is approved and certified by the consultant - M/s.Sound wizard with in a week.

Delivery time – 25 days from the date of supply order till 20.04.2010.
 Warrant as specified in the conditions

The materials should be delivered at our premises (door delivery) and materials should be covered with Insurance up to Kalakshetra Foundation/Chennai. Freight and Freight insurance will be additional at actual will be paid producing the bills.

The material delivered should be in original packing WITHOUT tampering with the original manufacturer's packing and in good condition.

The above supply order should be effected and completed in all respects by 20.04.2010. If the progress of the supply is found to be not satisfactory or the total supply is not completed in all respects as per the schedule as mentioned above, this supply order will automatically cease without notice and without assigning any reason.

Your acceptance of the conditions as indicated above may please be intimated to us within one week after the receipt of this letter by email.

Kindly acknowledge receipt of the letter.

Leela Samson
 Director

One more no placed below for Signature please,

For approval.

[Handwritten initials]

[Handwritten initials]

CAO

Leela
 DIRECTOR
 (127)



रसो वै सः

126
kalakshetra
F O U N D A T I O N

C:\ 2009-2010\V.Admin\2. Engineering\i.Plan\d.Sound systems\koothambalam.doc

March 24, 2010

M/s. Sennheiser Electronics India Private limited,
39-42B Edmonton Shopping Mall, Hotel Bristol,
M.G.Road, Gurgaon,
Hariyana 122 002, India.

Sub: Supplying of Audio Equipments/Micro phones – Kalakshetra Foundation -Supply Order - Reg.
Ref: Your offer dated Nil

Based on the recommendation given by the consultant M/s.Sound Wizard, approved by the works committee, The Director, Kalakshetra Foundation is pleased to award the supply order for Supplying of Audio equipments/Micro phones at a total cost of Rs. 6, 73,047/- (Rupees Six Lakh seventy three thousand forty seven only), as per the Annexure specification, terms and condition, enclosed herewith in all respects. This is a firm rate contract. General term and conditions applicable to this order is attached. The rate inclusive of VAT, Transit Insurance/Freight and excludes Octroi / Entry tax excludes and will be paid at actual.

The payment will be disbursed after the material is approved and certified by the consultant - M/s.Sound wizard with in a week.

Delivery time – 25 days from the date of supply order till 20.04.2010.
Warrant as specified in the conditions

The materials should be delivered at our premises (door delivery) and materials should be covered with Insurance up to Kalakshetra Foundation/Chennai. Freight and Freight insurance will be additional at actual will be paid producing the bills.

The material delivered should be in original packing WITHOUT tampering with the original manufacturer's packing and in good condition.

The above supply order should be effected and completed in all respects by 20.04.2010. If the progress of the supply is found to be not satisfactory or the total supply is not completed in all respects as per the schedule as mentioned above, this supply order will automatically cease without notice and without assigning any reason.

Your acceptance of the conditions as indicated above may please be intimated to us within one week after the receipt of this letter by email.

Kindly acknowledge receipt of the letter.

Leela Samson
Director

Recd in
M/s. Sound Wizard
dr 24/3/10
130
C.P. Ramani



Founder : Smt. Rukmini Devi Chairman : Justice Sri S. Mohan Former Judge Supreme Court
Director : Ms Leela Samson Member Secretary : Sri R.V. Ramani Governing Board

Kalakshetra Foundation Thiruvaniyur Chennai 600 041
Tel: 0091-(0)44-2452 0836 / 4057 / 1844 Fax : 0091-(0)44-2452 4359
Email : info@kalakshetra.in Website : www.kalakshetra.in



E&E SYSTEMS

By FIRST FLIGHT

To

KALAKSHETRA FOUNDATION,
THIRUVANMIYUR

CHENNAI - 600041.

KIND ATTN: Ms. LEELA SAMSON.

TEL: 044 - 24520836/4057.

F 25

309783

E&E Systems (India) Pvt Ltd

#14, Bhattarahalli Old Madras Road, K.R. Puram, Bangalore - 560 049, India
Tel.: +91 (0) 80 41903270 Fax: +91 (0) 80 41903005

(131)

128



E&E SYSTEMS

Date: 31/03/2010

To,

Kind Attn: Ms Leela Samson

Kalakshetra Foundation,

Thiruvanmiyur ,

Chennai -41 ,

Tamil Nadu.

Sub: Supply of Audio Equipment -Kalakshetra Foundation-Supply Order –Reg.

Ref : Offer No. PI No:002/Kala/04.02.2010

We hereby confirm the receipt and acceptance of the Works Order for the Kalakshetra Foundation.

All the Terms & Conditions mentioned in Annexure 3 are acceptable by us.

For E & E Systems (India) Pvt Ltd.

Shyam Suresh

Sales/Project Engineer



130
105

E&E Systems (India) Pvt Ltd

Regd. Off. : 82/83, Borewell Road, Whitefields

Bangalore - 560 066, India

Tel. : +91 (0) 80 41743030

Fax : +91 (0) 80 28456467

D.C. No. TEL/CHE/08-09

To Mrs. Kaleshika - Foundations

Chennai - 41

OUTWARD CHALLAN

TELERAD

(A Division of Ambalal Sarabhai Enterprises Ltd.)

146/B, Second Floor, Millennium Tower,
Nelson Manickam Road, Chennai - 600 029.
Telefax : 23745359, 23745360, 23744883

Date : 01/01/11

No.	Description	Quantity	Remarks
1.	MZ H 3040 Metal Goodrich	03	
2.	ME 34 (rod/10)	03	against
3.	MZ TV 31 (riddle hand)	03	young
4.	MZ W 36 P10 (corn/field)	03	purchase order
5.	F 45 G 2 (Keral set)		
6.	F 122 G 2 (Keral set)	06	
7.	MZ H 3040		

Customer's Signature



134

FOR TELERAD

D.C. No. TEL/CHE/08-09

To: M/s Kalashoka Foundations

Chennai At:

K of Attn: Mr. Srinivasan.
OUTWARD CHALLAN

TELERAD
(A Division of Ambalal Sarabhai Enterprises Ltd.)
146/8, Second Floor, Millennium Tower,
Nelson Manickam Road, Chennai - 600 029.
Telefax : 23745359, 23745360, 23744883

Date: 21/04/10.....

No.	Description	Quantity	Remarks
1.	MZ H 304 0 Metal Coorsneer	03	againt
2.	ME 34 Conclutor	03	young
3.	MZ TX 3 1 cable stand	03	purchase order
4.	MZ W 86 pro cuncil stand	03	
5.	E w - 135 G 3 Vocal set	06	
6.	E w 122 G 3 presentation set		
	HSPT 200 Head stand 3 cartons packed 1 box		
	Return 1 cores and 2		

Customer's Signature

[Handwritten signature]
Return to customer's
Chennai



135

D.C. No. TEL/CHE/08-09

OUTWARD CHALLAN

TELERAD

(A Division of Ambalal Sarabhai Enterprises Ltd.)

146/B, Second Floor, Millennium Tower,
Nelson Manickam Road, Chennai - 600 029,
Telefax : 23745359, 23745360, 23744883

To

*M/s Kalarshetra Foundation
Chennai*

Date : *22/11/10*

No.	Description	Quantity	Remarks
1.	<p><i>HSP - E004</i></p> <p><i>Electrical misc</i></p> <p><i>IN 3/4 110</i></p> <p><i>Kalarshetra</i></p> <p><i>SECURITY Dept</i></p> <p><i>KALAKSHETRA FOUNDATION</i></p> <p><i>THIRUVANMIYUR,</i></p> <p><i>CHENNAI - 600 041</i></p> <p><i>(R. Kalishetty)</i></p>	06	<p><i>Refer your</i></p> <p><i>purchase</i></p> <p><i>order</i></p> <p><i>132</i></p>

Customer's Signature

97

For TELERAD

136

D.C. No. TEL/CHE/08-09

OUTWARD CHALLAN

TELERAD

(A Division of Ambalal Sarabhai Enterprises Ltd.)

146/8, Second Floor, Millennium Tower,
Nelson Manickam Road, Chennai - 600 029.
Telefax : 23745359, 23745360, 23744883

Date : 03/04/10

To M/s Kalakshetra Foundation
Chennai

No.	Description	Quantity	Remarks
16	HS P - EW 4 Electrical mic IN 3/4/10 SECURITY Dept. KALAKSHETRA FOUNDATION THIRUVANMIYUR, CHENNAI - 600 041 (R. Kalishan Var)	06	repeat your purchase order

Customer's Signature

For TELERAD

(137)

C:\ 2009-2010\V.Admin\2. Engineering\i.Plan\d.Sound systems\koothambalam.doc	March 31, 2010
--	----------------

Sub: Up gradation of Sound system in Koothambalam – Change of suppliers – Supply of Micro Phones - Payment – Approval of – Reg.

Ref: Work committee approval dated 6.11.2009 ✓
Change of suppliers and works committee approval dated 24.3.2010 ✓

Based on the approval by the Works Committee, as recommended by the consultant M/s.Sound wizard the supply order for supplying of Micro Phones products was entrusted to M/s. Sennheiser India Pvt Ltd at a total cost of Rs.6, 73,047/- nett, as per the specification of equipment given by the consultant.

Further, M/s.Sennheiser India Pvt Ltd given the authorization to receive the supply order effect the delivery of materials and make the payment to M/s.Telerad on behalf of M/s.Sennheiser India Pvt Ltd. The letter of authorization is enclosed herewith.

M/s. TELERAD on behalf of M/s.Sennheiser India Pvt Ltd, who is the authorized dealer has delivered all the materials to the Foundation. Our consultant had verified the delivered packing materials and stated that received materials as per specification, invoice and checked in good condition and recommended to release the payment in the invoice copy of the supplier.

To M/s. TELERAD,
Vide Invoice No. TEL/CHE/T/301227 dated 31.03.2010 ... 6,73,047/-

Submitted for approval, please.

[Signature]
CEO
- *[Signature]*
AO
[Signature]

(an lemm)
CAO

[Signature] 8/4
DIRECTOR

138

Contact Details Inbox X**S.Gopinadhan to me**[show details](#) Mar 29 (10 d

Dear Sir,

Further to our telephone conversation please find below my contact information.

Regards,

S.Gopinadhan (Poncho)
Executive Director

E&E SYSTEMS (INDIA) PVT LTD

#14, Bhatrahalli Old Madras Road
KR Puram Bangalore - 560049, India

Phone: +91 (0) 80 41903270

Fax: +91 (0) 41903005

Direct: +91 (0) 80 41903880

Mobile: +91 9343771035

Email: poncho@enesystemsindia.comWebsite: www.enesystemsindia.com

image001.jpg

12K [View](#) [Download](#)[Reply](#) [Forward](#)**Works kalakshetra** Dear sir, We have despatched our supply order for supplying audio equipments ...**S.Gopinadhan to me**[show details](#) Mar 29 (10 d

Dear Sir,

We will keep you updated as soon as we have the works order.

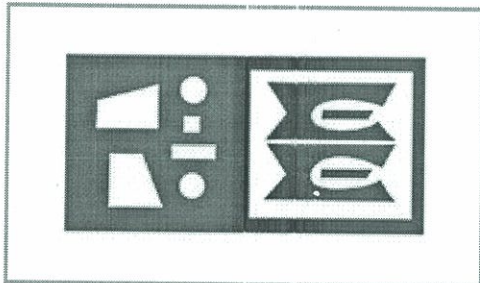
Regards,

Poncho

From: Works kalakshetra [<mailto:works@kalakshetra.in>]**Sent:** Monday, March 29, 2010 5:15 PM**To:** S.Gopinadhan**Subject:** Re: Contact Details

- Show quoted text -

139

KALAKSHETRA ORDER-- AUTHORISATION LETTER REQ.

Spam X

from **TELERAD CHENNAI** <teleradchennai@airtelmail.in> [hide details](#) Apr 6 (2 days)
to works@kalakshetra.in
cc **MKTG CHENNAI** <sales.chennai@teleradindia.com>
date Tue, Apr 6, 2010 at 1:00 PM
subject **KALAKSHETRA ORDER-- AUTHORISATION LETTER REQ.**

Dear Mr.Srinivasan,

We would like to submit the authorisation letter received from our principals M/s.Sennheiser India to exec the payment to be made.

As we have supplied the material well in time, kindly release our payment at the earliest.

with kind regards
T.P.Kumar

 **IMG.pdf**

140
25

Sennheiser Electronics India Private Limited
102 A, First Floor, Time Tower, M.G. Road,
Sector 28, Gurgaon, Haryana-122002, India
Phone +91- (124) 4187800
Fax: +91 (124) 4187830

Email : info@sennheiserindia.com
www.sennheiserindia.com

TO
THE DIRECTOR,
KALAKSHETRA FOUNDATION,
THIRUVANMIYUR,
CHENNAI-600041.

Dated:05.04.2010

Dear Sir,

Ref: Your supply order C:/2009-2010/V.Admin/2.Engineering/i.Plan/d.Sound
Systems/Koothambalam.doc dtd.March,24 2010

We sincerely acknowledge the receipt of your above mentioned supply order for the supply of SENNHEISER MICROPHONES. In this connection we wish to inform that as per our policy, we do the sales in INDIA, through our official distributors appointed in the respective region.

In this connection, we hereby authorize our exclusive distributor for SOUTH -- M/S.TELERAD to execute this order. M/S.TELERAD, CHENNAI will supply the ordered items and we also recommend that the payment shall be released to them directly, once the supply is completed.

Thanking You,

Yours truly
For Sennheiser Electronics India Pvt Limited.

Vipin Pungalia

Business Group Head-Professional Segment

Sennheiser Electronics India Private Limited
102 A, First Floor, Time Tower, M.G. Road,
Sector 15, Gurgaon, Haryana-122002, India
Phone +91- (124) 4187800
Fax: +91 (124) 4187830

Email: info@sennheiserindia.com
www.sennheiserindia.com

TO
THE DIRECTOR,
KALAKSHETRA FOUNDATION,
THIRUVANMIYUR,
CHENNAI-600041.

Dated:05.04.2010

Dear Sir,

Ref: Your supply order C:/2009-2010/V.Admin/2.Engineering/i.Plan/d.Sound
Systems/Koothambalam.doc dtd.March,24 2010

We sincerely acknowledge the receipt of your above mentioned supply order for the supply of SENNHEISER MICROPHONES. In this connection we wish to inform that as per our policy, we do the sales in INDIA, through our official distributors appointed in the respective region.

In this connection, we hereby authorize our exclusive distributor for SOUTH -- M/S.TELERAD to execute this order. M/S.TELERAD, CHENNAI will supply the ordered items and we also recommend that the payment shall be released to them directly, once the supply is completed.

Thanking You.

Yours truly
For Sennheiser Electronics India Pvt Limited.

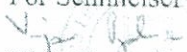
Vipin Pungalia

Business Group Head-Professional Segment

142

TELERAD

139

SONY

146/8, Second Floor, Millenium Towers,
(Nr. to Mehta Nagar Bus Stop),
Nelson Manickam Road, Chennai - 600 029.
Telefax : 23744883, 23745359 / 60, 43553070
Email: teleradchennai@airtelmail.in
www.teleradindia.com

Date: 12/04/2010

STAMPED RECEIPT

Received with thanks the sum of Rs. 6,73,047.00 /- (SIX LAKH SEVENTY THREE THOUSAND FORTY SEVEN ONLY) from KALAKSHETRA FOUNDATION, CHENNAI, towards the final settlement against our Invoice: TEL/CHE/T/301227 Dt.: 31/03/2010 for the supply sennheiser audio products against your Purchase Order No. C:/2009-2010/V.ADMIN/2 ENGINEERING/ I. PLAN/SOUND SYSTEM/KOOTHAMBALAM.DOC Dated:24/03/2010

For TELERAD

Authorised Signatories



Vide chequeno. 362803
dt 31.3.10
canarabank Athuramur
For Rs. 6,73,047/-

T43
92

Authorised Agents for **SONY** Professional Video Systems

A DIVISION OF AMBALAL SARABHAI ENTERPRISES LTD., REGD. OFFICE : WADI WADI, VADHODHARA - 309 007

Update about Kalakshetra Inbox X

from **Fabien** <fabien@soundwizard.net> [hide details](#) Apr 26 (3 d
 to Works kalakshetra <works@kalakshetra.in>
 cc Didier Weiss <didier@soundwizard.net>,
 Kumbha Young Grenier <kumbha@soundwizard.net>,
 Leela Samson <leelasamson@kalakshetra.in>
 date Mon, Apr 26, 2010 at 3:23 PM
 subject Update about Kalakshetra

Dear Srinivasan,

I still haven't received the serial numbers. I need it, especially for the damage piece....
 What is the update about the civil work, the designs decision....?
 If the sound booth is upstairs, we will need to review the wiring.
 Keep me updated.
 Thank you

Best regards,

Fabien

Sound Wizard
Pro Audio Acoustic Design

Shakti Area 9
Auroville 605 101 (Via Pondicherry)
Tamil Nadu, India
Phone (0) 413 262 26 59
Phone (0) 413 262 24 80

www.soundwizard.net

[Reply](#) [Reply to all](#) [Forward](#)

from **Works kalakshetra** <works@kalakshetra.in> [hide details](#) Apr 27 (2 d
 to Fabien <fabien@soundwizard.net>
 date Tue, Apr 27, 2010 at 11:04 AM
 subject Re: Update about Kalakshetra
 mailed-by kalakshetra.in

Dear Fabien,

Sorry for the delay for giving the information. Details of the
 EAW - NTL 720 speaker

SI.No. (21) AKD1264

DATE. OM15807

Warm regards

V.Srinivasan
 Kalakshetra Foundation

44

141

from **Works kalakshetra** works@kalakshetra.in
to Didier
<didier@soundwizard.net>, Fabien
<fabien@soundwizard.net>
date Mon, Aug 9, 2010 at 12:42 PM
subject Fwd: supply of materials - Reg.
mailed-by kalakshetra.in

[hide details](#) 12:42 PM (1 minute ago)

- Hide quoted text -

----- Forwarded message -----
From: **Works kalakshetra** <works@kalakshetra.in>
Date: Mon, Aug 9, 2010 at 12:42 PM
Subject: supply of materials - Reg.
To: poncho@enesystemsindia.com

Sir,

with reference to your earlier email dated 22 July 2010, stating that all the materials ordered to you, shall be supplied with in 15 days. No materials received sofar.

Please let us know your position for supplying of materials.

warm regards

V.Srinivasan

145

from **S.Gopinadhan** hide details 12:54 PM (44 minutes ago)
 <poncho@enesystemsindia.com>
 to Works kalakshetra
 <works@kalakshetra.in>
 date Mon, Aug 9, 2010 at 12:54
 PM
 subject RE: supply of materials - Reg.

Dear Sir,

We are expecting the material to be delivered to us by today (currently in transit form Chennai to Bangalore) and we will invoice and ship out the same to you by tomorrow and provide the dispatch details to you.

Warm regards,

Poncho

From: Works kalakshetra [mailto:works@kalakshetra.in]
Sent: Monday, August 09, 2010 12:42 PM
To: poncho@enesystemsindia.com
Subject: supply of materials - Reg.

Sir,
- Show quoted text -

No virus found in this incoming message.
 Checked by AVG - www.avg.com
 Version: 9.0.851 / Virus Database: 271.1.1/3059 - Release Date: 08/08/10 23:27:00

146

143

Alp



Canara Bank

Thiruvanniyur, चेन्नई - 600041
Thiruvanniyur, Chennai - 600041

CBS BRANCH बॉक | SB

PAY TO/सु: E & E Systems (India) Pvt. Ltd.

दिनांक Date 20/08/2010

या शतक कोर-Beater

रुपये Rupees *Thirteen Lacs Thirty five thousand three hundred and ninety eight only*

₹. 13,35,398/-

खा. नं.
A/c No.
2010MSHAO

26491081719

IFSC : CNRB002649

FOR KALAKSHETRA FOUNDATION
As per
AUTHORISED SIGNATORIES
Vela Lawstry

341844 6000150781

10

KL HI-TECH SECURE PRINT LTD.06/2010

151

142

Kalakshetra
FOUNDATION

C:\ 2010-2011\Admin\2. Engineering\i.Plan\d.Sound systems\koothambalam.doc	August 20, 2010
--	-----------------

M/s. E & E Systems (India) Pvt Ltd,
No 82 & 83, Borewell Road,
Whitefields,
Bangalore 560 066.

Sir(s)

Sub: Supplying of Speaker systems– Payment - Reg

Ref: Vide Invoice No.62 dated 11.08.2010

Please find enclosed a cheque for Rs.13,35,398/- (Rupees thirteen lakh thirty five thousand three hundred and ninety eight only) Vide cheque No. 341844, drawn in Canara bank, Thiruvanmiyur branch, Chennai, in favour of M/s. E & E Systems (India) Pvt Ltd, towards supply of speaker systems products as per the invoice referred above, *except SI.No.2 item which was not approved by the Comptroller.*

Kindly acknowledge receipt of the letter.

Further, you are requested to supply the balance sound equipments at the earliest as per the supply order entrusted to you.

T.S.
Murthi

T.S.Murthi
Chief Accounts Officer.

ole

148

1. Sender's Account Number **95584**
 2. Invoice to Receiver Receiver's account number **1**
 SE **LIABLE FOR UNPAID CHARGES**

3. Customer Reference (Information you would like on the invoice (if required))

4. From (Collection Address)
 Name: **SYSTEMS (INDIVIDUAL) 1984 1984**
 Address:

City: **CHATELAIN** Postal / Zip Code: **92000**
 Contact Name: **YVES** Tel. No.: **92000 116**
 CST/IST/TIN/VAT No.

5. To (Receiver)
 Name: **INDUSTRIE AERONAUTIQUE**
 Address: **1984 1984**
 City: **CHATELAIN** Postal / Zip Code: **92000**
 Contact Name: **YVES** Tel. No.: **92000 116**
 CST/IST/TIN/VAT No.

6. Delivery Address
 Name: **INDUSTRIE AERONAUTIQUE**
 Address: **1984 1984**
 City: **CHATELAIN** Postal / Zip Code: **92000**
 Contact Name: **YVES** Tel. No.: **92000 116**
 CST/IST/TIN/VAT No.

7. Dangerous Goods
 Does this consignment contain any dangerous goods? Yes No
 If yes, please call our Customer Service.
 Your Signature: **(Signature)** Received by TNT: **(Signature)**
 Date: **1/1/1984** (Day/Month/Year) Date: **1984 11 1** Time: **10:11**

Sending Depot: **INDUSTRIE AERONAUTIQUE**
 Receiving Depot: **INDUSTRIE AERONAUTIQUE**



DO 604 159 292 WW
 Please quote this number if you have an enquiry.



8a. Services

Special Express
 9:00 Express
 10:00 Express
 12:00 Express
 Express
 Economy Express
 Air Freight

8b. Options

Priority
 Enhanced Liability
 Rs: **15,223,851**
 FTC
 VTC

9. Special Delivery Instructions

Pay 10000 PRODEFIN: 1984 1984

10. Goods Descriptions

General Description	Number of items	Weight Kilos	Weight Grams	Length	Width	Height
SPINNETT	16					
PARIS						
Total	16	400				

11. Service Sticker
16 boxes
Stewart
RECEIVER'S COPY

1984



E&E SYSTEMS (INDIA) PVT LTD

Reg. Off. : 82/83, Borewell Road, Whitefields, Bangalore - 560 066, India Tel. : +91 (0) 80 41903883 Fax : +91 (0) 80 41903005

146

TAX INVOICE

(Original)

E & E Systems (India) Pvt Ltd No.82 & 83, Borewell Road Whitefield Bangalore-560066		Invoice No. 62	Dated 11-Aug-2010
Consignee Kalakshetra Foundation Thiruvanmiyur Chennai - 600-041 Contact Person: Srinivas Ph.No: 044-24524359		Delivery Note 62	Mode/Terms of Payment
Buyer (if other than consignee) Kalakshetra Foundation Thiruvanmiyur Chennai		Supplier's Ref.	Other Reference(s)
		Buyer's Order No.	Dated
		Despatch Document No.	Dated 11-Aug-2010
		Despatched through TNT by Road	Destination Chennai
		Terms of Delivery	

SI No.	Description of Goods	Quantity	Rate	per	Amount
1	UB 82e Black ✓ SI.No: 99710790AKC10001	1 no	99,360.00	no	99,360.00
2	EAW FC 700C ✓	2 no	16,470.00	no	32,940.00
3	EAW VR61 Black ✓ SI.No:0010496AKCH0018/17/16/01/19/02	6 no	28,890.00	no	1,73,340.00
4	EAW NTL 720 Black ✓ SI.No:(21)AKD2107/2083	2 no	3,35,750.00	no	6,71,500.00
5	Mackel Amplifier FRS 1700 ✓ SI.No.002540301CGBZ0044/15/30/50/25/21	6 no	38,727.00	no	2,32,362.00
					12,09,502.00
VAT CST @13.5% Round on / Off					1,63,282.77
					0.23
		Total	16 no		13,72,785.00

2-pens 1 pen
14 pens
Box
over
over

1176562
1,58,836
0.23 13.50 %
13,35,398

Amount Chargeable (in words)

Rs. Thirteen Lakh Seventy Two Thousand Seven Hundred Eighty Five Only

E. & O.E

Approved for payment (check item n°2)

SOUND WIZARD
 # 9, Shakti - Area, Auroville - 605 101.
 Tamil Nadu - India
 Tel : 0413 - 2622 659, 480, 482
 E-mail: info@soundwizard.net
 www.soundwizard.net



Company's VAT TIN : 29830841467
 Company's CST No. : 29830841467
 Company's Service Tax No. : AACCE1438RST001
 Company's PAN : AACCE1438R

Declaration
 We declare that this invoice shows the actual price of the goods described and that all particulars are true and correct.

for E & E Systems (India) Pvt Ltd

Authorised Signatory

This is a Computer Generated Invoice

Please send us your Form 'C' per return of Post.
 This invoice is issued subject to terms & conditions printed overleaf.
 Interest at 21% will be charged if not paid within due date.
 Subject to Bangalore Jurisdiction

133
 SECURITY Dept.
 KALAKSHETRA FOUNDATION

150

143

C:\ 2009-2010\V.Admin\2. Engineering\i.Plan\d.Sound systems\koothambalam.doc	August 19, 2010
--	-----------------

Sub: Up gradation of Sound system in Koothambalam – Supply of Speaker systems products
Payment – Approval of – Reg.

Ref: Work committee approval dated 6.11.2009 P 2
 Work committee approval dated 24.3.2010 P 115
 Supply order letter dated March 24, 2010. P 122

Based on the approval by the Works Committee, as recommended by the consultant M/s.Sound wizard the supply order for supplying of speaker system products was entrusted to M/s. E & E Systems India pvt ltd / Bangalore at a total cost of Rs.19,27,488/- (Rupees Nineteen lakh twenty seven thousand four hundred and eighty eight only) inclusive of VAT..

P 143

M/s. E & E Systems India pvt ltd / Bangalore have delivered part materials in 10 boxes - packed materials to the Kalakshetra Foundation 16.08.2010. Further, our consultant had verified the delivered packing materials and stated that received materials as per specification except Item No.2 in the invoice and checked in good condition and recommended to release the payment to the supplier in the invoice copy of the supplier.

To M/s.. E & E Systems (India) pvt ltd,
 Vide Invoice No.62 dated 11.08.2010 ... 13,35,398/-

Submitted for approval for making payment to the supplier M/s.. E & E Systems (India) pvt ltd, for Rs.13, 35,398/- please.

BP-3-114
 20.8.2010

[Signature]
 EO

[Signature]
 AO 15/8/10
 Ja

[Signature]
 CAO

[Signature]
 DIRECTOR 24/8

151

REGISTERED MAIL ONE

डाक सेवार्थ
on Postal
Service

KALAKSHETRA FOUNDATION
THIRUVANMIYUR.
CHENNAI-600 041

प्रेषक डाकघर की नाम-मोहर
Name - Stamp of office of posting



F.O
20/8/10

आर.पी. 54
R.P.-54

भारतीय डाक विभाग

DEPARTMENT OF POSTS-INDIA

प्राप्ति स्वीकृति / ACKNOWLEDGEMENT

नावश्यक को काट दिया जाए
Strike out if not relevant

रजिस्ट्री-पत्र/पार्सल प्राप्त हुआ
Received Registered Letter/Parcel

क्रमांक/No.	तारीख/Dated	का/of

- बीमे का मूल्य रूपयों में M/S, B & E Systems (India)
- Insured for Rupees pyltd

पाने वाले N. 82 & 83, Borewell Road,
Addressed to Whitefield,

(152)



भारतीय डाक विभाग

152



E&E SYSTEMS (INDIA) PVT LTD

149

Reg. Off. : 82/83, Borewell Road, Whitefields, Bangalore - 560 066, India Tel. : +91 (0) 80 41903883 Fax : +91 (0) 80 41903005

TAX INVOICE

(Triplicate)

E & E Systems (India) Pvt Ltd
No.82 & 83, Borewell Road
Whitefield
Bangalore-560066

Invoice No.	Dated
62	11-Aug-2010
Delivery Note	Mode/Terms of Payment
62	
Supplier's Ref.	Other Reference(s)
Buyer's Order No.	Dated
Despatch Document No.	Dated
	11-Aug-2010
Despatched through	Destination
TNT by Road	Chennai
Terms of Delivery	

Consignee
Kalakshetra Foundation
Thiruvanniyur
Chennai - 600041
Contact Person: Srinivas
Ph.No: 044-24524359
Buyer (if other than consignee)
Kalakshetra Foundation
Thiruvanniyur
Chennai

SI No.	Description of Goods	Quantity	Rate	per	Amount
1	UB 82e Black SI.No: 99710790AKC10001	1 no	99,360.00	no	99,360.00
2	EAW FC 700C	2 no	16,470.00	no	32,940.00
3	EAW VR61 Black SI.No:0010496AKCH001B/17/16/01/19/02	6 no	28,890.00	no	1,73,340.00
4	EAW NTL 720 Black SI.No:(21)AKD2107/2083	2 no	3,35,750.00	no	6,71,500.00
5	Mackei Amplifier FRS 1700 SI.No:002540301CGBZ0044/15/30/50/25/21	6 no	38,127.00	no	2,32,362.00
					12,09,502.00
CST @13.5% Round on / Off					1,63,282.77 0.23
Total					16 no 13,72,785.00

Amount Chargeable (in words)

Rs. Thirteen Lakh Seventy Two Thousand Seven Hundred Eighty Five Only

E & O E

Approved for payment (except item n^o2)

Company's VAT TIN : 29830841467
 Company's CST No. : 29830841467
 Company's Service Tax No. : AACCE1438RST001
 Company's PAN : AACCE1438R

Declaration
We declare that this invoice shows the actual price of the goods described and that all particulars are true and correct.

SOUND WIZARD
 # 9, Shakti - Area, Auroville - 605 101,
 Tamil Nadu - India
 Tel : 0413 2622 659, 480, 482
 E-mail : info@soundwizard.net
 www.soundwizard.net

for E & E Systems (India) Pvt Ltd

Authorised Signatory

This is a Computer Generated Invoice

Please send us your Form 'C' per return of Post.
This invoice is issued subject to terms & conditions printed overleaf.
Interest at 21% will be charged if not paid within due date.
Subject to Bangalore Jurisdiction

133
 SECURITY Dept. 16/8/10
KALAKSHETRA FOUNDATION
 THIRUVANMIYUR,
 CHENNAI - 600 041.

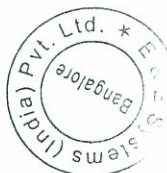

153

Received by
E. & O. E.



LS9

Works kalakshetra <works@kalakshetra.in>

Pending supply - Reg.

Works kalakshetra <works@kalakshetra.in>
To: "S.Gopinadhan" <poncho@enesystemsindia.com>

Mon, Oct 4, 2010 at 4:03 PM

Sir,

Ref: Your email dated August 9 - 2010.

As per the email reply cited above that the balance materials are expecting to be delivered to day (i e 10th august 2010) in transit.

Sofar we have not received the materials, by the by we commenced the sound equipment commissioning work for the Koothambalam.

We expecting your reply in line with supply of pending materials and position please at the earliest.

Warm regards

V.Srinivasan.
Kalakshetra

LS9
81

151

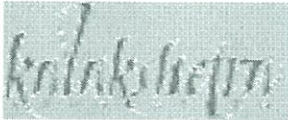

Works kalakshetra <works@kalakshetra.in>

details of supply M/s.E& E

Works kalakshetra <works@kalakshetra.in>

Mon, Oct 18, 2010 at 5:34 PM

To: Fabien <fabien@soundwizard.net>

Hi,

Except the scanned bill materials, we had not received any shipment afterwards.

Final shipment due from M/s.E&E is yet to be received which is long time pending since March 2010.

warm regards

V.Srinivasan
Kalakshetra

[Quoted text hidden]

S

155
80



Works kalakshetra <works@kalakshetra.in> (152)

Pending materials supply - remainder - reg.

Works kalakshetra <works@kalakshetra.in>

Mon, Oct 18, 2010 at 5:40 PM

To: "S.Gopinadhan" <poncho@enesystemsindia.com>, Fabien <fabien@soundwizard.net>, Didier <didier@soundwizard.net>

Sir,

Ref: Your email dated August 9 - 2010.

As per the email reply cited above that the balance materials are expecting to be delivered to day (i e 10th august 2010) in transit.

Sofar we have not received the materials, by the by we commenced the sound equipment commissioning work for the Koothambalam.

We expecting your reply in line with supply of pending materials and position please at the earliest.

Warm regards

V.Srinivasan.
Kalakshetra

(156)
79

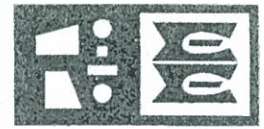

157

E&E SYSTEMS

Date: 27/10/2010

To Whomsoever it May concern

This is to Certify that we are sending this parcel to the below mentioned address through TNT Courier by ~~ROAD MODE~~ AIR SHIPMENT.

We are sending this material AS A WARRENTY REPLACEMENT SPARE PART
This is not meant for sale. The value of the material is Rs, 5,000/-

To,

KALAKSHETRA FOUNDATION
THIRUVANMIYUR
CHENNAI - 600041
PH: 044-24520836 / 4057 / 1844
Contact Person: MS. LEELA SAMSON

Thanks & Regards.



[Handwritten signature]

For E&E Systems India

157

E&E Systems (India) Pvt Ltd

EVOMA Business Park,
#14, Bhatrahalli Old Madras Road
KR Puram, Bangalore - 560049, India
Tel.: +91 (0) 80 41903883 / 80 / 81 / 79
Fax: +91 (0) 80 41903005



E&E SYSTEMS

Date: 27/10/2010

To Whomsoever it May concern

This is to Certify that we are sending this parcel to the below mentioned address through TNT Courier by ~~ROAD MODE~~ AIR SHIPMENT

We are sending this material AS A WARRENTY REPLACEMENT SPARE PART
This is not meant for sale. The value of the material is Rs, 5,000/-

To,

KALAKSHETRA FOUNDATION
THIRUVANMIYUR
CHENNAI - 600041
PH: 044-24520836 / 4057 / 1844
Contact Person: MS. LEELA SAMSON

Thanks & Regards.

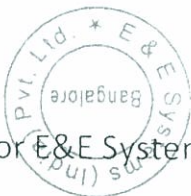

For E&E Systems India



E&E Systems (India) Pvt Ltd

EVOMA Business Park,
#14, Bhatrahalli Old Madras Road
KR Puram, Bangalore - 560049, India
Tel. : +91 (0) 80 41903883 / 80 / 81 / 79
Fax : +91 (0) 80 41903005



E&E SYSTEMS

153

Date: 27/10/2010

To Whomsoever it May concern

This is to Certify that we are sending this parcel to the below mentioned address through TNT Courier by ~~ROAD MODE~~ AIR SHIPMENT

We are sending this material AS A WARRENTY REPLACEMENT SPARE PART
This is not meant for sale. The value of the material is Rs, 5,000/-

To,

KALAKSHETRA FOUNDATION
THIRUVANMIYUR
CHENNAI - 600041
PH: 044-24520836 / 4057 / 1844
Contact Person: MS. LEELA SAMSON

Thanks & Regards.



[Handwritten signature]

For E&E Systems India

159

E&E Systems (India) Pvt Ltd

EVOMA Business Park,
#14, Bhatrahalli Old Madras Road
KR Puram, Bangalore - 560049, India
Tel. : +91 (0) 80 41903883 / 80 / 81 / 79
Fax : +91 (0) 80 41903005

1. Sender's Account Number **95594**
 2. Invoice to Receiver **SENDER LIABLE FOR UNPAID CHARGES**
 Receiver's account number

3. Customer Reference (Information you would like on the invoice (if required))

4. From (Collection Address)
 Name: **FAC SYSTEMS PVT LTD**
 Address:

City: **B'LORE** Postal / Zip Code: **560049**
 Contact Name: Tel. No.:
 CST/ST/IN/VAT No.

5. To (Receiver)
 Name: **MALAVISHETRA FOUNDATION**
 Address:

City: **CHENNAI** Postal / Zip Code: **600041**
 Contact Name: Tel. No.:
 CST/ST/IN/VAT No.

6. Delivery Address
 Name: **825**
 Address: **25**
 City: Postal / Zip Code:
 Contact Name: Tel. No.:
 CST/ST/IN/VAT No.

7. Dangerous Goods
 Does this consignment contain any dangerous goods? Yes No
 If yes, please call our Customer Service.
 CARRIAGE OF THIS CONSIGNMENT IS SUBJECT TO THE TERMS AND CONDITIONS ON THE REVERSE
 Your Signature: _____
 Date: / / (Day/Month/Year) Received by TNT: **9/10/10** Time: **AM**

Sending Depot: _____ Receiving Depot: _____

TNT

DO 477 525 819 WW

Please quote this number if you have an enquiry.

8a. Services
 Special Express
 9:00 Express
 10:00 Express
 12:00 Express
 Economy Express
 Air Freight

8b. Options
 Documents Non-Documents
 Priority
 Enhanced Liability
 Rs. **5000/-**
 FTC
 VTC

9. Special Delivery Instructions
MVA 935910, PRIORITY, DISM

10. Goods Descriptions

General Description	Number of Items	Weight	Dimensions
		Kilos Grams	Length Width Height
FLYBIRD HARBR	01	3.750	
Ops Verification			
Sat No.	Total	Volume	Volume Weight
	01		

11. Service Sticker
-1-3
 RECEIVER'S COPY

99



Instructions Replacement NTL720 Side Panel



Warning: Installation should only be done by an experienced technician. Improper installation may result in damage to the equipment, injury or death.

These instructions enable the technician to replace the right or left NTL720 Side Panel using either:
0030277-90 Kit Replacement Side Panel NTL720 Right
0030278-90 Kit Replacement Side Panel NTL720 Left

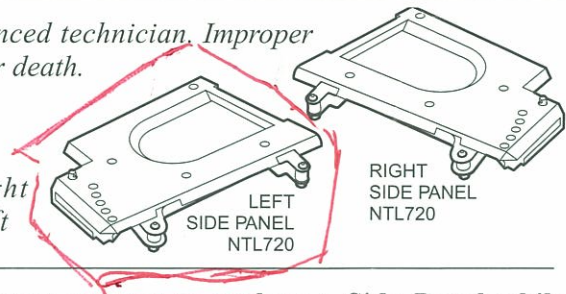

Introduction

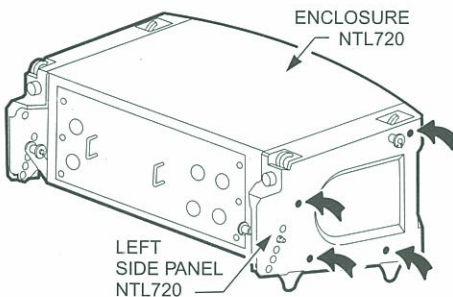

WARNING: Never attempt to replace a Side Panel while the Enclosure is in an array.

Each NTL720 Enclosure has a Right and a Left Side Panel. Each Side Panel is attached to the Enclosure by 4 Flat Tipped Screws. These 4 Screws are located inside the Panels and are reached by Access Holes. The locations of these Access Holes are marked by the arrows. These Mounting Screws are mechanically attached in the Side Panel and even after their threads are fully disengaged from the Enclosure, they remain a component in the Side Panel Assembly.

Removing the old Side Panel

1. Insert the Screwdriver into an Access Hole & remove the threaded portion of the Mounting Screw from the Enclosure.
2. Repeat for all 4 Mounting Screws.

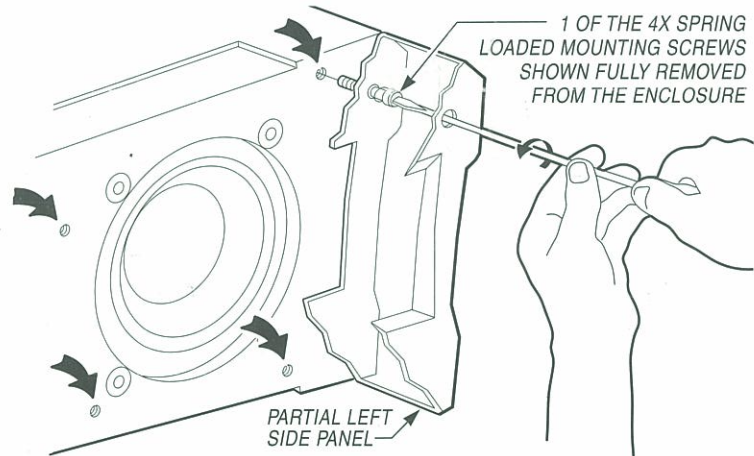

Installing the new Side Panel

3. Apply a drop of Loctite 222 on the thread of each of the mounting screws.
4. Position the replacement Side Panel to the Enclosure.
5. Insert the Screwdriver into an Access Hole & push the Spring Spring Loaded Screw. It will extend toward the Enclosure. Fit the screw into the threaded insert & tighten. Repeat for all 4 Screws.
6. Torque each Screw to 46 kg-cm [39.9 lb-in.]

If you have any questions about replacing the Right or Left NTL720 Side Panel, please contact the EAW Application Support Group for assistance:

EAW ASG	Tel	800-992-5013 (USA only)
One Main Street	Tel	508-234-6158
Whitinsville, MA 01588 USA	Fax	508-234-3776
	E-mail	asg @eaw.com

Thank you for purchasing EAW products

The Laws of Physics | The Art of Listening



EAW is the worldwide technological and market leader in the design and manufacture of high-performance, professional loudspeaker systems.

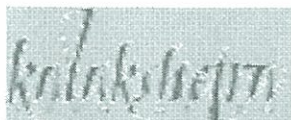

Works kalakshetra <works@kalakshetra.in>

Change of suppliers - reg.

Works kalakshetra <works@kalakshetra.in>

Fri, Oct 29, 2010 at 2:15 PM

To: Fabien <fabien@soundwizard.net>, Didier <didier@soundwizard.net>

Dear Fabien and Didier,

Based on your email dated oct 26, 2010, balance supply of EAW Audio equipments will be drawn from M/s.E & E systems (India) Pvt ltd as recommended.

Further decided to entrust the supply order (as per your specification) to M/s.MRH/Mumbai

Accordingly, the formalise the paper work is being done by the office to submit the works committe for approval for change of suppliers for the pending supply.

For above, you are requested to send the justification note for **termination of supply order** to M/s.E& E systems in email and followed by hard copy in post to this office.
(the termination of supply order to M/s.E & E is enclosed as attachment)

Please see and give the comments please.

The procedure to be followed to the change of supplier, as needed by the works committee.

First we should issue the termination of supply order to the supplier
Justification note for change of supplier with reason and cost as you given before

Kindly provide the above at the earliest.

Warm regards,

V.Srinivasan.



termination of supply order.doc

11K

167



Works kalakshetra <works@kalakshetra.in>

(Che-Kala) -- Update of equipment situation

Fabien Bontems <fabien@soundwizard.net>

Tue, Oct 26, 2010 at 5:14 PM

To: leelasamson@kalakshetra.in

Cc: Didier <didier@soundwizard.net>, Works kalakshetra <works@kalakshetra.in>, Kumbha Young Grenier <kyg@soundwizard.net>

Dear Leela,

Hope this mail finds you well.

Here is an update of the equipment situation.

As you know, some of the equipments are yet to come from E&E for EAW products.

They are not supplying and it has been dragging for too long.

I had a meeting with Didier and we do not want to delay the opening of the auditorium so we took the call of specifying another brand for the remaining equipment. The quality of the system will not suffer.

I have done a new list and it is in the same budget as agreed earlier. Stock is available now.

I already have a quote. I am attaching it to this mail.

We still have to order the projector enclosure and cables.

I am still waiting for the cable length required from electrical team before asking for quotation.

Should need any other information, feel free to contact me.

Thank you

--

Best regards,

Fabien

Sound Wizard
Acoustic & Pro Audio Design

Shakti Area 9
Auroville 605 101 (Via Pondicherry)
Tamil Nadu, India
Phone (0) 413 262 26 59
Phone (0) 413 262 24 80

www.soundwizard.net



10-10-25 MRH Quote.jpg
271K

163



MRH DIGITAL SYSTEMS™ PRIVATE LIMITED

P. O. Box 4050, 290 Lamington Road, Mumbai 400 007, India.
Phone: (91-22) 2387 3615 - 2386 8578 - 2389 6086 - 2389 5383 / 84 / 85
Fax: (91-22) 2387 3618 E-Mail: sales@mrhdigital.com

160

REF : 019/MRHDS/010-11

DATE : 25.10.2010

TO,
THE DIRECTOR,
KALA KSHETRA FOUNDATION
THIRUVANMIYUR,
CHENNAI - 600 041.

Dear Sir,

This is with reference to your enquiry, We are pleased to submit our offer as under :-

SR. NO.	ITEM DESCRIPTION	QTY	UNIT PRICE	TOTAL PRICE
1	QSC AMPLIFIER - RMX 4050 HD	1	76090.00	76090.00
2	QSC SPEAKER - ADS 282 H	2	40998.00	81996.00
3	QSC SPEAKER - ADS 82 H	10	19118.00	191180.00
4	QSC BRACKET - ADI D8	10	5370.00	53700.00
5	QSC SPEAKER - ADS 52	4	9584.00	38336.00

TERMS ON SALES :-

12.5% CST WILL BE CHARGED EXTRA.

IMMEDIATE DELIVERY WILL BE SENT ON FREIGHT TO PAY BASIS.

100% PAYMENT AGAINST DELIVERY.

VALIDITY :- 30 DAYS.

GUARANTEE PERIOD : 1 YEAR FROM THE DATE OF MANUFACTURE.

441302 | -
55,163 | -
4,96,465 | -

Thanking You.

For MRH Digital Systems Pvt Ltd.

Ajit Thakur.

71
164

161

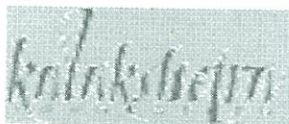

Works kalakshetra <works@kalakshetra.in>

draft -termination of supply order - reg.

Works kalakshetra <works@kalakshetra.in>
To: Fabien Bontems <fabien@soundwizard.net>

Sat, Oct 30, 2010 at 10:31 AM

Hi fabien,

well and good I will ^{issue} the termination of supply order to M/s.E & E systems and payment for EAW FC 700 C -2 Nos supplied and balance 6 Nosclips are yet to be received before payment of the same.
quoting the same in the termination order.

Two more quotes from the agency may be forwarded to this at the earliest to place the balance materials supply to M/s.MRH please.

Justification note for termination of supply order on M/s.E & E and cost analysis. The recommendation to issue to supply on M/s.MRH comparing the two agencies (yet to be received).

based on this, the approval may be obtained from the committee and order will be released to M/s.,MRH.

warm regards

V.Srinivasan
kalakshetra
[Quoted text hidden]

165

Based on the above statement and approval of works committee, the supply order for supplying speaker balance equipments was issued and M/s. E& E systems / Bangalore at a total cost of Rs.19,27,488/-, fright and insurance cost extra.

The part of shipment and equipment was supplied by the agency on 16.8.2010 for a value of Rs.13, 72,785/-. The payment was made to the supplier after the inspection / checking, approval and recommendation for payment by the consultant M/s.Sound Wizard. The balance equipments not supplied by the M/s.E & E systems /Bangalore sofar, costs Rs.5,54,703/- (Rs.19,27,488-13,72,785/-)

The sound consultant M/s.Sound Wizard now sent email that the supply order balance materials pending supply from M/s. E & E systems / Bangalore) to be placed on M/s.MRH Digital systems with change of specification, at a total cost of Rs.4,96,465/- fright charges extra, after terminating the supply order of M/s.E& E systems / Bangalore. The same is placed below for approval please.

We may request for the justification note for change of suppliers and revised quotation from the suppliers from the consultant M/s.Sound wizard, for on record please.

Submitted for approval please,

EO

1.11.10
AO

CAO

DIRECTOR 4/11

DIRECTOR

P.T.KRISHNAN

166

69

- 2 -

- Since the model, specification of the equipment has been changed/selected by the consultant M/s.sound wizard, further quote from the M/s.Aditya InfoTech ltd, was not appraised by the consultant.
- The fresh quotations for the supplying balance sound equipments (as per the list) as per the selected models and changed specifications equipments were called by the consultant from various manufactures and brand, and the quotes were received by the Foundation as directed.

For supplying of Micro phones, the quotation received from the suppliers and comparative statement (placed below)

Sl. No.	Name of the suppliers	Quoted value	Position	Total cost to be awarded-L1
1	M/s.Sennheiser India Pvt Ltd	Rs.6,73,047/-	L 1	Rs.6,73,047/
2	M/s.Sasi Enterprises	Rs7,34,966/-	L 2	
3	M/s.Telerad	Rs.7,20,967/-	L 3	

Based on the above statement and approval of works committee, the supply order for supplying Micro phone was issued and M/s.Senheiser India Pvt ltd supplied all the materials as per the supply order brand and specification and the payment was made to the supplier after the inspection / checking, approved and recommended for payment by the consultant M/s.Sound Wizard.

For supplying of speaker (balance) updated version, the quotation received from suppliers and comparative statement (placed below)

Sl. No.	Name of the suppliers	Quoted value	Position	Total cost to be awarded-L1
1	M/s.E & E systems /Bangalore	Rs19,27,488/-	L 1	Rs.19,27,488 /Freight and Insurance will be additional at actual.
2	M/s.MRH Digital systems pvt ltd, Mumbai	Rs20,23,878/-	L 2	
3	M/s.Resonaltors Bangalore	Rs22,00,019/-	L 3	

.....3

DRAFT

C:\ 2009-2010\V.Admin\2. Engineering\i.Plan\Sound equipments .doc	October 29, 2010
---	------------------

Sub: **Note – Submission** - Koothambalam – Sound equipments - EAW
And Audix products (QSC Products) – **Change of suppliers** – Approval
of - Reg.

Ref: Approval dated 6.11.2009 (placed below please) Page 2
Change of suppliers approval note dated 15.02.2010 / 18.02.2010 Page 115
Sound consultant M/s.Sound Wizard email dated 26.10.2010 Page 159.

In continuation of the above approval note, the supply order for supplying of EAW and Audix products was awarded to M/s.Aditya InfoTech / Chennai at a total cost of Rs.61, 70,870/-Nett. The part of shipment and equipment was supplied by the agency on 25.11.2009 for a value of Rs.36, 98,944/-. The payment was made to the supplier after the inspection / checking, approved and recommended for payment by the consultant M/s.Sound Wizard.

Further, balance equipment supply was not supplied by M/s.Adityainfotech due to uncertainty. The sound consultant decided to the change of supplier and given direction to place the balance materials supply order on two suppliers namely M/s.E& E systems and M/s.Sennheiser India at a total cost of Rs.19,27,488/- and Rs.6,73,047/- respectively.

Accordingly, the supply order on the above suppliers was issued after taken the following procedure.

- The termination of contract / Supply order, was issued to the agency M/s.Aditya info Tech Limited, Nungambakkam, based on the recommendation / remarks given by the consultant M/s.Sound wizard. The receipt of the letter of termination of supply order (Balance materials) was received from the postal acknowledgement on 29.02.2010.
- Further, the reason for Non-supply of the balance materials as per the work order from M/s.Aditya InfoTech ltd has been received.

....2

168

Due to delay in delivery of these items, we have suffered enormous loss in ~~the~~ ^{the} schedule for completion of the project. Since you have not adhere to ~~the~~ time schedule for delivery, the supply order issued to you to the above supply for the pending materials is henceforth is cancelled. Kindly note that the payment for the supply material ~~is already by us except SI 2. It is already made by us. (original 22)~~ ^{is already made by us. (original 22)}

Kindly acknowledge the receipt of the letter and confirm termination of the balance equipment [✓] supply.

Yours faithfully,

Leela Samson
Director

Draft for approval please

[Handwritten signature]

[Handwritten signature]
4.11.10
AO

[Handwritten signature]
4/11/10
AO

Culal 4/11
DIRECTOR

C:\ 2009-2010\V.Admin\2. Engineering\i.Plan\d.Sound systems\koothambalam.doc	October 29, 2010
--	------------------

M/s. E & E Systems (India) Pvt Ltd,
 # 14, Bhattrahalli, Old Madras Road,
 Near Garden City College,
 K.R.Puram,
 Bangalore 560 049,
 India.

Sir(s)

Sub: ~~Supply of Audio Equipments – Kalakshetra Foundation~~ **Termination of Supply order** - Reg

Ref: Your offer No.Pl.No:002/Kala/04.02.2010 dated 04.02.2010

Our supply order No. C\2009-2010\V.Admin\2.Engineering\i.Plan\d.Sound systems \koothambalam.doc dated - March 24, 2010.

Recommendation from the consultant M/s.Sound Wizard

Please refer to our supply order cited at second reference and we acknowledge the following materials delivered for which payment was already made:-

S No.	Unit	Qty.
1	UB 82e Black	1 No.
2.	EAW FC 700C	2 Nos supplied, balance 6 Nos clips are yet to be received before payment of the same after certified by the consultant
3.	EAW VR61 Black	6 Nos.
4.	EAW NTL 720 Black	2 Nos.
5.	Mackei Amplifier FRS 1700	6 Nos.

The following items are still remaining to be delivered, ^{even though} ~~Eventually~~ the delivery should have been completed by 30.4.2010.

S.No.	Unit	Qty.
1	UB 82e Black	1 No.
2.	EAW VR61 Black	14 Nos.

170

Due to delay in delivery of these items, we have suffered enormous loss in the schedule for completion of the project. Since you have not adhered to the time schedule for delivery, the supply order issued to you to the above supply for the pending material is henceforth is cancelled. Kindly note that the payment for the supplied material is already made by us except SL2. (EAW FC 700C)

Kindly acknowledge the receipt of the letter and confirm termination of the balance equipment supply.

Yours faithfully,

Leela Samson
Director

(171)



by RPMD

168

C:\ 2009-2010\V.Admin\2. Engineering\i.Plan\d.Sound systems\koothambalam.doc	October 29, 2010
--	------------------

M/s. E & E Systems (India) Pvt Ltd,
14, Bhattrahalli, Old Madras Road,
Near Garden City College,
K.R.Puram,
Bangalore 560 049,
India.

Sir(s)

Sub: **Termination of Supply order - Reg**

Ref: i) Your offer No.Pl.No:002/Kala/04.02.2010 dated 04.02.2010

ii) Our supply order No. C\2009-2010\V.Admin\2.Engineering\i.Plan\d.Sound systems \koothambalam.doc dated - March 24, 2010.

Please refer to our supply order cited at second reference and we acknowledge the following materials delivered for which payment was already made:-

S No.	Unit	Qty.
1	UB 82e Black	1 No.
2.	EAW FC 700C	2 Nos supplied, balance 6 Nos clips are yet to be received before payment of the same after certified by the consultant
3.	EAW VR61 Black	6 Nos.
4.	EAW NTL 720 Black	2 Nos.
5.	Mackei Amplifier FRS 1700	6 Nos.

The following items are still remaining to be delivered. Even though; the delivery should have been completed by 30.4.2010.

S.No.	Unit	Qty.
1	UB 82e Black	1 No.
2.	EAW VR61 Black	14 Nos.

..... 2

(172)



AE Ankur **ELECTRONICS**

169
Regd. Office:
47-Off. Old Nagardas Road,
19, Shanti Kunj, Andheri (E),
Mumbai - 400 069. Ph.: 832 99 22

REF : 029/AF/2010-11
RAILWAYS & GOVT. SUPPLIERS FOR ELECTRICALS, ELECTRONICS
& TELECOMMUNICATION SPARES & EQUIPMENT & GENERAL
SUPPLIERS.

Sales & Admn Office: **DATE : 30.10.2010**
Bombay Market Apartments,
Basement No. B-20,
Tardeo Road, Mumbai - 400 034.
Ph.: 493 1052 / 495 4381.

TO,
THE DIRECTOR,
KALA KSHETRA FOUNDATION
THIRUVANMIYUR,
CHENNAI - 600 041.

Dear Sir,

This is with reference to your enquiry, We are pleased to submit our offer as under :-

<u>SR. NO.</u>	<u>ITEM DESCRIPTION</u>	<u>QTY</u>	<u>UNIT PRICE</u>	<u>TOTAL PRICE</u>
1	QSC SPEAKER - ADS 82 H	10	19700.00	197000.00
2	QSC SPEAKER - ADS 52	4	9875.00	39500.00
3	QSC SPEAKER - ADS 282 H	2	42250.00	84500.00
4	QSC BRACKET - ADI D8	10	5540.00	55400.00
5	QSC AMPLIFIER - RMX 4050 HD	1	78370.00	78370.00

TERMS ON SALES :-

12.5% CST WILL BE CHARGED EXTRA.

IMMEDIATE DELIVERY WILL BE SENT ON FREIGHT TO PAY BASIS.

100% PAYMENT AGAINST DELIVERY.

VALIDITY :- 30 DAYS.

GUARANTEE PERIOD : 1 YEAR FROM THE DATE OF MANUFACTURE.

Thanking You.

For Ankur Electronics

Deepak Dalal.

DIRECTOR.



170

Calibre

Sound Systems Pvt. Ltd.

REF : 025/CAL/010-11

DATE : 30.10.2010

TO,
THE DIRECTOR,
KALA KSHETRA FOUNDATION
THIRUVANMIYUR,
CHENNAI - 600 041.

Dear Sir,

This is with reference to your enquiry, We are pleased to submit our offer as under :-

SR. NO.	ITEM DESCRIPTION	QTY	UNIT PRICE	TOTAL PRICE
1	QSC SPEAKER - ADS 52	4	9775.00	39100.00
2	QSC AMPLIFIER - RMX 4050 HD	1	77620.00	77620.00
3	QSC SPEAKER - ADS 282 H	2	41820.00	83640.00
4	QSC BRACKET - ADI D8	10	5480.00	54800.00
5	QSC SPEAKER - ADS 82 H	10	19500.00	195000.00

TERMS ON SALES :-

- 12.5% CST WILL BE CHARGED EXTRA.
- IMMEDIATE DELIVERY WILL BE SENT ON FREIGHT TO PAY BASIS.
- 100% PAYMENT AGAINST DELIVERY.
- VALIDITY :- 30 DAYS.
- GUARANTEE PERIOD : 1 YEAR FROM THE DATE OF MANUFACTURE.

Thanking You.

For Calibre Sound Systems Pvt Ltd.

V. Singh
Vijay Singh.

Calibre
Sound Systems Pvt. Ltd.
R. No. 21, 290 Lamington Road,
Mumbai - 400 007. India

DIRECTOR

174

Regd. Office : Room No. 21, 2nd Floor,
290 Lamington Road, Mumbai 400 007.



#9, Shakti Area, Auroville 605101 (near Pondicherry), T.N., INDIA
Phone: +91(0)413 2622 659, 480, 482
E-mail: info@soundwizard.net

171

1st November 2010

To the kind attention of:

Kalakshetra Foundation
Thiruvanmiyur,
Chennai – 600 041

Dear Sir,

Due to uncertainty of delivery of the remaining materials from E&E Systems (India) Pvt Ltd, we have taken the decision of changing supplier in order not to delay the project any further.

Remaining EAW material:

- EAW UB 82e Black: 1 nos – Rs.99,360 per piece
- EAW VR61 Black: 14 nos – Rs.28,890 per piece

EAW order value: Rs.5,03,820

Recommended QSC as replacement material:

- QSC ADS-82H (VR61 replacement): 10nos – Rs.19,118 per piece
- QSC ADS52 (VR61 replacement): 4 nos – Rs.9,584 per piece
- QSC ADS282H (UB 82e replacement): 2 nos – Rs.40,998 per piece
- QSC ADI D8 (brackets for ADS-82H): 10 nos – Rs.5370 per piece
- QSC RMX 4050HD (amplifier for ADS-282H): 1 nos – Rs.76,090 per piece

QSC order value: Rs.4,41,302

We recommend MRH as the supplier for QSC products.

Yours faithfully,

Fabien Bontems

DIRECTOR .

175

172



Works kalakshetra <works@kalakshetra.in>

Change of suppliers - justification note - reg.

Fabien Bontems <fabien@soundwizard.net>
To: Works kalakshetra <works@kalakshetra.in>
Cc: System Design <sd@soundwizard.net>

Mon, Nov 1, 2010 at 1:54 PM

Dear Srinivasan,

Find enclosed the justification letter as well as the 2 other quotes.
We are sending you the hard copies asap.
Thank you

Best regards,

Fabien

Sound Wizard
Acoustic& Pro Audio Design

Shakti Area 9
Auroville 605 101 (Via Pondicherry)
Tamil Nadu, India
Phone (0) 413 262 26 59
Phone (0) 413 262 24 80

www.soundwizard.net

[Quoted text hidden]

3 attachments

 **ankur.pdf**
843K

 **calibrel .pdf**
619K

 **Kalakshetra Justification note.pdf**
63K

DIRECTOR .

176



MRH DIGITAL SYSTEMS™ PRIVATE LIMITED

P. O. Box 4050, 290 Lamington Road, Mumbai 400 007, India.
Phone: (91-22) 2387 3615 - 2386 8578 - 2389 6086 - 2389 5383 / 84 / 85
Fax: (91-22) 2387 3618 E-Mail: sales@mrhdigital.com

173

REF : 019/MRHDS/010-11

DATE : 25.10.2010

TO,
THE DIRECTOR,
KALA KSHETRA FOUNDATION
THIRUVANMIYUR,
CHENNAI - 600 041.

Dear Sir,

This is with reference to your enquiry, We are pleased to submit our offer as under :-

SR. NO.	ITEM DESCRIPTION	QTY	UNIT PRICE	TOTAL PRICE
1	QSC AMPLIFIER - RMX 4050 HD	1	76090.00	76090.00
2	QSC SPEAKER - ADS 282 H	2	40998.00	81996.00
3	QSC SPEAKER - ADS 82 H	10	19118.00	191180.00
4	QSC BRACKET - ADI D8	10	5370.00	53700.00
5	QSC SPEAKER - ADS 52	4	9584.00	38336.00

TERMS ON SALES :-

12.5% CST WILL BE CHARGED EXTRA.
IMMEDIATE DELIVERY WILL BE SENT ON FREIGHT TO PAY BASIS.
100% PAYMENT AGAINST DELIVERY.
VALIDITY :- 30 DAYS.
GUARANTEE PERIOD : 1 YEAR FROM THE DATE OF MANUFACTURE.

Thanking You.
For MRH Digital Systems Pvt Ltd.

Ajit Thakur
Ajit Thakur.

441302
12.5% 55163 -
496465 / -

Toicylu - Charges extra

177

AE Ankur **ELECTRONICS**

Regd. Office:
47-Off. Old Nagardas Road,
19, Shanti Kunj, Andheri (E),
Mumbai - 400 069, Ph.: 832 99 22

174

REF : 029/AE/100-11
RAILWAYS & GOVT. SUPPLIERS FOR ELECTRICALS, ELECTRONICS
& TELECOMMUNICATION SPARES & EQUIPMENT & GENERAL
SUPPLIERS.

Sales & Admn Office: **DATE : 30.10.2010**
Bombay Market Apartments,
Basement No. B-20.
Tardeo Road, Mumbai - 400 034.
Ph.: 493 1052 / 495 4381.

TO,
THE DIRECTOR,
KALA KSHETRA FOUNDATION
THIRUVANMIYUR,
CHENNAI - 600 041.

Dear Sir,
This is with reference to your enquiry, We are pleased to submit our offer as under :-

SR. NO.	ITEM DESCRIPTION	QTY	UNIT PRICE	TOTAL PRICE
1	QSC SPEAKER - ADS 82 H	10	19700.00	197000.00
2	QSC SPEAKER - ADS 52	4	9875.00	39500.00
3	QSC SPEAKER - ADS 282 H	2	42250.00	84500.00
4	QSC BRACKET - ADI D8	10	5540.00	55400.00
5	QSC AMPLIFIER - RMX 4050 HD	1	78370.00	78370.00

TERMS ON SALES :-

12.5% CST WILL BE CHARGED EXTRA.
IMMEDIATE DELIVERY WILL BE SENT ON FREIGHT TO PAY BASIS.
100% PAYMENT AGAINST DELIVERY.
VALIDITY :- 30 DAYS.
GUARANTEE PERIOD : 1 YEAR FROM THE DATE OF MANUFACTURE.

454770/-
12.5% 56846.25
5,11,6625

Thanking You.
For Ankur Electronics

Deepak Dalal
Deepak Dalal.

[Large signature]

Freight extra -

178

57

175

Calibre

Sound Systems Pvt. Ltd.

REF : 025/CAL/010-11

DATE : 30.10.2010

TO,
THE DIRECTOR,
KALA KSHETRA FOUNDATION
THIRUVANMIYUR,
CHENNAI - 600 041.

Dear Sir,

This is with reference to your enquiry, We are pleased to submit our offer as under :-

SR. NO.	ITEM DESCRIPTION	QTY	UNIT PRICE	TOTAL PRICE
1	QSC SPEAKER - ADS 52	4	9775.00	39100.00
2	QSC AMPLIFIER - RMX 4050 HD	1	77620.00	77620.00
3	QSC SPEAKER - ADS 282 H	2	41820.00	83640.00
4	QSC BRACKET - ADI D8	10	5480.00	54800.00
5	QSC SPEAKER - ADS 82 H	10	19500.00	195000.00

TERMS ON SALES :-

- 12.5% CST WILL BE CHARGED EXTRA.
- IMMEDIATE DELIVERY WILL BE SENT ON FREIGHT TO PAY BASIS.
- 100% PAYMENT AGAINST DELIVERY.
- VALIDITY :- 30 DAYS.
- GUARANTEE PERIOD : 1 YEAR FROM THE DATE OF MANUFACTURE.

12.5% 450160 —
 56270 —
 506430 —
 Total - extra —

Thanking You.

For Calibre Sound Systems Pvt Ltd.

V. Singh
 Vijay Singh. **Calibre**
 Sound Systems Pvt. Ltd.
 R. No. 21, 290 Lamington Road,
 Mumbai - 400 007, India.

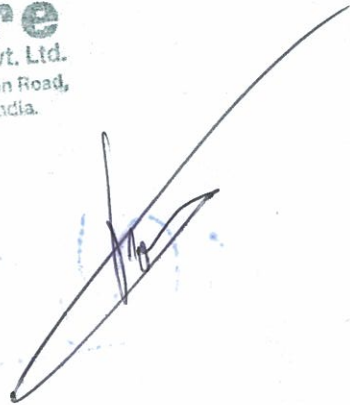

179

Regd. Office : Room No. 21, 2nd Floor,
290 Lamington Road, Mumbai 400 007.



#9, Shakti Area, Auroville 605101 (near Pondicherry), T.N., INDIA
Phone: +91(0)413 2622 659, 480, 482
E-mail: info@soundwizard.net

2/11
AD/CRS
2/10

1st November 2010

To the kind attention of:

Kalakshetra Foundation
Thiruvanmiyur,
Chennai – 600 041

Dear Sir,

Due to uncertainty of delivery of the remaining materials from E&E Systems (India) Pvt Ltd, we have taken the decision of changing supplier in order not to delay the project any further.

Remaining EAW material:

- EAW UB 82e Black: 1 nos – Rs.99,360 per piece
- EAW VR61 Black: 14 nos – Rs.28,890 per piece

EAW order value: Rs.5,03,820

Recommended QSC as replacement material:

- QSC ADS-82H (VR61 replacement): 10nos – Rs.19,118 per piece
- QSC ADS52 (VR61 replacement): 4 nos – Rs.9,584 per piece
- QSC ADS282H (UB 82e replacement): 2 nos – Rs.40,998 per piece
- QSC ADI D8 (brackets for ADS-82H): 10 nos – Rs.5370 per piece
- QSC RMX 4050HD (amplifier for ADS-282H): 1 nos – Rs.76,090 per piece

QSC order value: Rs.4,41,302

We recommend MRH as the supplier for QSC products.,

Yours faithfully,

Fabien Bontems

For SOUND WIZARD

Executive

180

- 4 -

The Consultant M/s.Sound wizard recommended M/s.MRH Digital systems pvt ltd as the supplier for QSC products.

- Page 176 -

Submitted for approval for placing the supply order on M/s.MRH Digital Systems at a total cost of Rs4,96,465/- for the pending / balance supply due from the M/s.E & E systems Bangalore as revised and suggested by the Sound wizard after change of specification and materials.

Calu Samoth

DIRECTOR 9/11 2010

↓

Shri. P.T.KRISHNAN

/

Separate note
was sent to his
office vide Page 183

54
181

- 3 -

Based on the above statement and approval of works committee, the supply order for supplying speaker balance equipments was issued and M/s. E& E systems / Bangalore at a total cost of Rs.19,27,488/-, freight and insurance cost extra.

Page
120
121
122

The part of shipment and equipment was supplied by the agency on 16.8.2010 for a value of Rs.13, 72,785/-. The payment was made to the supplier after the inspection / checking, approval and recommendation for payment by the consultant M/s.Sound Wizard. The balance equipments not supplied by the M/s.E & E systems /Bangalore sofar, costs Rs.5,54,703/- (Rs.19,27,488-13,72,785/-)

Page
147
148
149

The sound consultant M/s.Sound Wizard now sent email that the supply order balance materials pending supply from M/s. E & E systems / Bangalore) to be placed on M/s.MRH Digital systems with change of specification, at a total cost of Rs.4,96,465/- freight charges extra, after terminating the supply order of M/s.E& E systems / Bangalore. The same is placed below for approval please.

Page
159

The termination of supply order to M/s. M/s.E & E systems /Bangalore was dispatched on 8.11.2010.

Page
167, 168

Further, the justification note for change of suppliers and revised quotations from the suppliers from the consultant M/s.Sound wizard was received and placed below. The comparative statement has been prepared and suggested to release the supply order on M/s.MRH Digital systems private limited at a total cost of Rs.496,465/-frieght charges extra.

Comparative statement for supplying pending / balance materials

Sl. No.	Name of the suppliers	Quoted value	Positi on	Total cost to be awarded-L1
1	M/s.MRH Digital systems pvt ltd, Mumbai	Rs4,96,465/-	L 1	Freight will be additional at actual.
2	M/s.Ankur Electronics , Mumbai	Rs5,11,616/-	L 2	Freight will be additional at actual
3	M/s.Calibre sound systems pvt ltd,Mumbai	Rs5,06,430/-	L 3	Freight will be additional at actual

Page 173

Page 174

Page 175

.....4

182

- 2 -

- Since the model, specification of the equipment has been changed/selected by the consultant M/s.sound wizard, further quote from the M/s.Aditya InfoTech ltd, was not appraised by the consultant.
- The fresh quotations for the supplying balance sound equipments (as per the list) as per the selected models and changed specifications equipments were called by the consultant from various manufactures and brand, and the quotes were received by the Foundation as directed.

For supplying of Micro phones, the quotation received from the suppliers and comparative statement (placed below) *page 60 to 62 & 110*

Sl. No.	Name of the suppliers	Quoted value	Position	Total cost to be awarded-L1
1	M/s.Sennheiser India Pvt Ltd	Rs.6,73,047/-	L 1	Rs.6,73,047/
2	M/s.Sasi Enterprises	Rs7,34,966/-	L 2	
3	M/s.Telerad	Rs.7,20,967/-	L 3	

Based on the above statement and approval of works committee, the supply order for supplying Micro phone was issued and M/s.Senheiser India Pvt ltd supplied all the materials as per the supply order brand and specification and the payment was made to the supplier after the inspection / checking, approved and recommended for payment by the consultant M/s.Sound Wizard.

*Page 126**Page 129 to 134*

For supplying of speaker (balance) updated version, the quotation received from suppliers and comparative statement (placed below) *page 63, 69 & 118.*

Sl. No.	Name of the suppliers	Quoted value	Position	Total cost to be awarded-L1
1	M/s.E & E systems /Bangalore	Rs19,27,488/-	L 1	Freight and Insurance will be additional at actual.
2	M/s.MRH Digital systems pvt ltd, Mumbai	Rs20,23,878/-	L 2	
3	M/s.Resonaltors Bangalore	Rs22,00,019/-	L 3	

.....3

185

52



C:\ 2009-2010\V.Admin\2. Engineering\i.Plan\Sound equipments .doc	October 29, 2010
---	------------------

Sub: **Note – Submission** - Koothambalam – Kalakshetra Foundation -Sound Equipments - EAW and Audix products (Changed as QSC Products) – **Change of suppliers** – Approval of - Reg.

Ref: Approval dated 6.11.2009 (placed below please) P-2 to 10
 Change of suppliers approval note dated 15.02.2010 / 18.02.2010 P-115
 Sound consultant M/s.Sound Wizard email dated 26.10.2010 P-159

In continuation of the above approval note, the supply order for supplying of EAW and Audix products was awarded to M/s.Aditya InfoTech / Chennai at a total cost of Rs.61, 70,870/-Nett. The part of shipment and equipment was supplied by the agency on 25.11.2009 for a value of Rs.36, 98,944/-. The payment was made to the supplier after the inspection / checking, approved and recommended for payment by the consultant M/s.Sound Wizard.

Page
22
23
24
25

Further, balance equipment supply was not supplied by M/s.Adityainfotech due to uncertainty. The sound consultant decided to the change of supplier and given direction to place the balance materials supply order on two suppliers namely M/s.E& E systems and M/s.Sennheiser India at a total cost of Rs.19,27,488/- and Rs.6,73,047/- respectively.

Page
36
37

Accordingly, the supply order on the above suppliers was issued after taken the following procedure.

- The termination of contract / Supply order, was issued to the agency M/s.Aditya info Tech Limited, Nungambakkam, based on the recommendation / remarks given by the consultant M/s.Sound wizard. The receipt of the letter of termination of supply order (Balance materials) was received from the postal acknowledgement on 29.02.2010.
- Further, the reason for Non-supply of the balance materials as per the work order from M/s.Aditya InfoTech ltd has been received.

Page
48
49
50

Page
66

....2

189

181



Works kalakshetra <works@kalakshetra.in>

change of suppliers - reg.

Works kalakshetra <works@kalakshetra.in>

Sat, Nov 13, 2010 at 12:56 PM

To: Fabien <fabien@soundwizard.net>, Didier <didier@soundwizard.net>

Cc: ao@kalakshetra.in

Bcc: CAO Kalakshetra <cao@kalakshetra.in>

Dear Fabien and Didier,

We are in receipt of your note, justification for change of suppliers for the balance sound equipment and the same was submitted for approval.

It is submitted for the following for clarification.

Initially, the supply order was issued to M/s. Aditya info tech (EAW and Audix products). the payment was made to the supplier and paid as recommended. further the balance material supply order was terminated after terminating the supply order as per your recommendation.

Then, the change of supplier, supply order (EAW and Audix products) was issued to M/s. E&Ebangalore for the balance materials. They supplied part materials and payment was made to them as per the recommendation. Balance material not delivered by the supplier, the supply order for the balance materials was terminated as per the recommendation.

Now the balance materials supply order wanted to entrust with M/s. MRH Digital pvt ltd for the (QSC Products- change of the specification) as recommended by you. The justification note and recommendation for placing the order on M/s. MRH does not contain the details.

Further you are requested to submit, the justification for change of specification with technical reason (EAW into QSC products) and change of supplier with reason in details. So that No objection will raise by our Audit people.

Kindly submit the above to proceed further.

Kindly sent your reply to administrative officer - ao@kalakshetra.in

warm regards.
V.Srinivasan
Kalakshetra.

185

kalakshetra

AO Kalakshetra <ao@kalakshetra.in>

change of suppliers - reg.

Didier <didier@soundwizard.net>

Mon, Nov 15, 2010 at 11:36 AM

To: Works kalakshetra <works@kalakshetra.in>

Cc: Fabien <fabien@soundwizard.net>, ao@kalakshetra.in, "-Kumbha YG ." <kyg@soundwizard.net>

Dear Mr. Srinivasan,

As per Fabien's letter dated Nov 1st, 2010, the change of specification is NOT of technical reason. If you look at the numbers, the EAW and QSC specifications are the same for all these remaining items to be purchased.

The change was triggered by the fact that the chain of supply for EAW from USA to Singapore to Chennai was delayed due to network reorganisation from EAW. We didn't want to take a chance and delay the final installation as per given schedule.

In any case, this change only concerns ancillary items, the main part of the sound system being on site already.

At your service for further details,

Didier

[Quoted text hidden]

Direct may kindly see

EO

*15/11/10
A.O.*

*Arul
Direct 18/11*

186

183

P.T. KRISHNAN

M.Arch. (Univ. of California)

ARCHITECT

1, Second Street, Wallace Garden, Chennai-600 006, INDIA
Phone: (044) 2833 4878, 2833 1759 ■ Fax: (044) 2833 1878

Q
12/11 A-12/11
12/11

November 12, 2010

Ms. Leela Samson
Director
Kalakshetra Foundation
Thiruvanmiyur
Chennai – 600 041.

Dear Ms. Samson,

Sub: Ongoing works at Kalakshetra

As a member of the Building Committee, I have been receiving and signing various papers related to the ongoing works. As a Committee Member, I would like to clarify that the responsibility of the Committee normally covers only the following:

1. Appointment of Consultant (Technical capability and financial terms)
2. Approval of design and planning proposals put forth by the consultants.
3. Approval of budgetary estimate and tender recommendations made by the consultant.
4. Approval of main contractors.
5. Approval of revised / additional budget provisions, if required.

However I find that papers are being sent to me for approval of rates and additional orders which are already covered within the available budgetary provision. These items should be processed internally by Kalakshetra along with the respective consultants and need not be put up to me for approval as I am not in a position to verify the correctness of the quantities, specifications and rates for the works carried out. I am returning the following files sent to me unsigned as all these works I understand are within the approved budget and they can be verified by the officials concerned.

1. Additional rates for wood items.
2. Digital enclosure covers approval of supplier and rate (high quote).
3. Changing of suppliers for sound equipments.

With kind regards

Yours sincerely,



(P.T. KRISHNAN)

Encl.: as above

ptk/sys1/fsm

187

184



#9, Shakti Area, Auroville 605101 (near Pondicherry), T.N., INDIA
Phone: +91(0)413 2622 659, 480, 482
E-mail: info@soundwizard.net

16th November 2010

To the kind attention of:

Kalakshetra Foundation
Thiruvanmiyur,
Chennai – 600 041

Dear Sir,

As per Fabien's letter dated Nov 1st, 2010, the change of specification is NOT of technical reason. If you look at the numbers, the EAW and QSC specifications are the same for all these remaining items to be purchased.

The change was triggered by the fact that the chain of supply for EAW from USA to Singapore to Chennai was delayed due to network reorganization from EAW. We didn't want to take a chance and delay the final installation as per given schedule.

Yours faithfully,

Didier Weiss

SOUND WIZARD
9, Shakti - Area, Auroville - 605 101.
Tamil Nadu - India
Tel : 0413 - 2622 659, 480, 482
E-mail : info@soundwizard.net
www.soundwizard.net

188

The sound consultant M/s.Sound Wizard now sent email that the supply order balance materials pending supply from M/s. E & E systems / Bangalore) to be placed on M/s.MRH Digital systems with change of specification, at a total cost of Rs.4,96,465/- freight charges extra, after terminating the supply order of M/s.E& E systems / Bangalore. The termination of supply order to M/s. M/s.E & E systems /Bangalore was dispatched on 8.11.2010.

Page 167, 168

The justification for change of suppliers (again) for EAW and Audix products into QSC products and the two more quotation was received and forwarded to this office by the consultant and recommended to release the supplier order for supplying of QSC products on M/s.MRH Digital private ltd

Page 172

Based on quotations received and forwarded by the consultant M/s.Sound wizard the comparative statement for supplying pending / balance materials is follows,

Sl.N o.	Name of the suppliers	Quoted value	Position	Total cost to be awarded-L1
1	M/s.MRH Digital systems pvt ltd, Mumbai	Rs4,96,465/-	L 1	Freight will be additional at actual.
2	M/s.Ankur Electronics , Mumbai	Rs5,11,616/-	L 2	Freight will be additional at actual
3	M/s.Calibre sound systems pvt ltd,Mumbai	Rs5,06,430/-	L 3	Freight will be additional at actual

Page 173

Page 174

Page 175

Submitted for approval for placing the supply order with the change of specification on M/s.MRH Digital Systems for the QSC products at a total cost of Rs4, 96,465/- for the pending / balance supply as recommended by the consultant M/s. Sound wizard.

EO

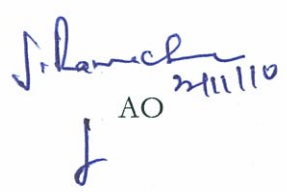
AO 24/11/10

CAO

DIRECTOR
24/11

The quotations thus issued to various suppliers and the quotes received from them and detailed below

i) Supply of Micro Phones,

Sl. No	Name of the suppliers	Quoted value	Position	Total cost to be awarded-L1
1	M/s.Sennheiser India Pvt Ltd	Rs.6,73,047/-	L 1	Rs.6,73,047/
2	M/s.Sasi Enterprises	Rs7,34,966/-	L 2	
3	M/s.Telerad	Rs.7,20,967/-	L 3	

Based on the above statement and approval of works committee, the supply order for supplying Micro phone was issued and M/s.Senheiser India Pvt ltd on 24.3.2010 and who supplied all the materials as per the supply order brand and specification. The payment was made to the supplier after the inspection / checking, approved and recommended for payment by the consultant M/s.Sound Wizard.

Page 126
Page 129
£134

The quotations thus issued to various suppliers and the quotes received from them and detailed below

Page 63,69,118

ii) Supply of speaker (balance)

Sl.No	Name of the suppliers	Quoted value	Position	Total cost to be awarded-L1
1	M/s.E & E systems /Bangalore	Rs19,27,488/-	L 1	Freight and Insurance will be additional at actual.
2	M/s.MRH Digital systems pvt ltd, Mumbai	Rs20,23,878/-	L 2	
3	M/s.Resonaltors Bangalore	Rs22,00,019/-	L 3	

Based on the above statement and approval of works committee, the supply order for supplying speaker balance equipments was issued and M/s. E& E systems / Bangalore at a total cost of Rs.19,27,488/-, fright and insurance cost extra.

Page 120-122

The part of shipment and equipment was supplied by the M/s. E& E systems / Bangalore on 16.8.2010 for a value of Rs.13, 72,785/-. The payment was made to the supplier after the inspection / checking, approval and recommendation for payment by the consultant M/s.Sound Wizard. The balance equipments not supplied by the M/s.E & E systems /Bangalore sofar, costs Rs.5,54,703/- (Rs.19,27,488-13,72,785/-)

Page 147
-149

.....3

190

Kalakshetra FOUNDATION

C:\ 2009-2010\V.Admin\2. Engineering\i.Plan\Sound equipments .doc	November 22, 2010
---	-------------------

Sub: Note – Submission - Koothambalam – Kalakshetra Foundation -Sound Equipments – EAW and Audix products (Changed as QSC Products)–Change of suppliers – Approval of - Reg.

- Ref: i) Approval dated 6.11.2009 (placed below please) P-2 -10
 ii) Change of suppliers approval note dated 15.02.2010 / 18.02.2010 P-115
 iii) Sound consultant M/s.Sound Wizard email dated 26.10.2010 P -159
 iv) Works committee member P.T.Krishnan note with remarks dated 12.11.10– P-183.
 v) Justification Note sent by the M/s.Sound Wizard email dated 16.11.2010 P-184&176

As per the note sent by the Works Committee Member, Shri.P.T.Krishnan vide reference cited above, the expenditure sanction and approval may be obtained internally by the Kalakshetra Foundation by concerned officials after obtaining the justification for change of suppliers, in view of technical aspects by the consultant M/s.Sound wizard. Then the above supply order may be issued to the suppliers who recommended by the consultant.

Page 183

In continuation of the above approval note, the supply order for supplying of EAW and Audix products was awarded to M/s.Aditya InfoTech / Chennai at a total cost of Rs.61,70,870/-Nett. The part of shipment and equipment was supplied by the agency on 25.11.2009 for a value of Rs.36,98,944/-. The payment was made to the supplier after the inspection / checking, approved and recommended for payment by the consultant M/s.Sound Wizard.

Page 22-25

Balance equipment supply was not supplied by M/s.Adityainfotech due to uncertainty. The sound consultant decided to the change of supplier and given direction to place the balance materials supply order on two suppliers namely M/s.E& E systems and M/s.Sennheiser India at a total cost of Rs.19,27,488/- and Rs.6,73,047/- respectively after adhering the following procedure.

Page 36, 37

- The termination of contract / Supply order, was issued to the agency M/s.Aditya info Tech Limited, Nungambakkam, based on the recommendation / remarks given by the consultant M/s.Sound wizard. The receipt of the letter of termination of supply order (Balance materials) was received from the postal acknowledgement on 29.02.2010.

Page 48-50

- Further, the reason for Non-supply of the balance materials as per the work order from M/s.Aditya InfoTech ltd has been received.

Page 66

- The fresh quotations for the supplying balance sound equipments (as per the list) as per the selected models and changed specifications equipments were called by the consultant from various manufactures and brand, and the quotes were received by the Foundation as directed.

Page 60-62
€ 110

191

187 a

ANNEXURE

S.No.	Item Description	Quantity	Rate per unit In Rs.	Total Amount in Rs.
1	QSC AMPLIFIER – RMX 4050 HD	1 No	76090	76090.00
2	QSC SPEAKER –ADS 282 H	2 Nos	40998	81996.00
3	QSC SPEAKER –ADS 82 H	10 Nos	19118	191180.00
4	QSC BRACKET –ADI D8	10 Nos	5370	53700.00
5	QSC SPEAKER –ADS 52	4 Nos	9584	38336.00
	Total			441302.00
	CST 12.5%			

M/s.MRH Digital Systems Private Limited,
P.O.Box 4050, 290 Lamington Road,
Mumbai 400 007, India.

(192)

Your acceptance of the conditions as indicated above may please be intimated to us within one week after the receipt of this letter by email.

Kindly acknowledge receipt of the letter.

Leela Samson
Director

Handwritten signature
EO

Handwritten signature
25-11-10
AO

Handwritten signature
CAO

Maybe Appd in view of approval accorded at page 185.

Handwritten signature
Deputy Director 26/11

Handwritten signature
DIRECTOR 29/11

Handwritten signature
AO

Handwritten circled number
193



Based on the approval note dated 24.11.2010, (Page 185) the draft of the supply order to M/s.MRH digital systems pvt ltd is submitted for approval before issue the supply order to the supplier please.

C:\ 2009-2010\V.Admin\2. Engineering\i.Plan\d.Sound Equipments\koothambalam.doc	November 25, 2010
---	-------------------

M/s.MRH Digital Systems Private Limited,
P.O.Box 4050, 290 Lamington Road,
Mumbai 400 007, India.

Sub: Supplying of Sound Equipments (QSC Products) -Supply order - Reg.
Ref: Your offer No.019/MRHDS/010-11 dated 25.10.2010.

Based on the recommendation given by the consultant M/s.Sound Wizard, approved by ~~The Director~~, Kalakshetra Foundation is pleased to award the supply order for Supplying of Sound equipments (QSC Products) at a total cost of Rs. 4, 41,302/- (Rupees Four lak^h forty one thousand three hundred and two only), plus 12.5 % CST, as per the ~~Annexure~~ specification, terms and condition, enclosed herewith, ~~in all respects~~. This is a firm rate contract. General term and conditions applicable to this order is attached.

Page 189a

The payment will be disbursed after the material is approved and certified by the consultant - M/s.Sound wizard with in a week.

Delivery time – immediate – till 10.12.2010.
Warrant /Guarantee - One year from the date of delivery.

The materials should be delivered at our premises (door delivery) and materials should be covered with Insurance up to Kalakshetra Foundation/Chennai. Freight and Freight insurance will be additional at actual will be paid producing the bills.

The material delivered should be in original packing WITHOUT tampering with the original manufacturer's packing and in good condition.

The above supply order should be effected and completed in all respects by 10.12.2010. If the progress of the supply is found to be not satisfactory or the total supply is not completed in all respects as per the schedule as mentioned above, this supply order will automatically cease without notice and without assigning any reason.

.....2

(194)

Professy

916

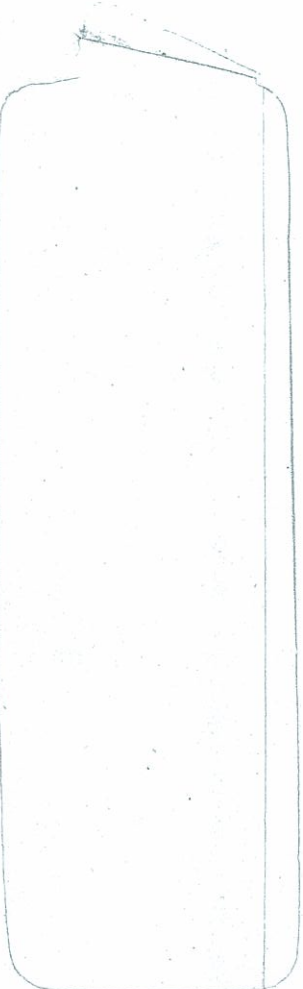

If undelivered please return to :
MRH DIGITAL SYSTEMS™
PRIVATE LIMITED
P. O. Box 4050, 290 Lamington Road, Mumbai 400 007, India.
Phone: (91-22) 23873615, 23895383 / 84 / 85 Fax: (91-22) 23873618

PO BOX 4050

MR SRINIVASAN

092104

78893

195

192

4304/-

NON-NEGOTIABLE AT OWNERS RISK

Customer Code 253470

Company MRF

Sender Naaghar

Address Vasai 401 210

M/T Date 15/12

Ship Date PG01

25 Camp-foods

2

M/R MRF

3

Kalakasheta Foundation
Tirumanthapur
Chennai 600041
9716478893
496464V

200kg

961

In case this consignment contains anything of value, the company recommends insurance of the same. The company's liability on this shipment is limited to Rs.5000/- or cost of reconstruction whichever is lower.

I/We hereby agree to the terms and conditions set forth on the reverse of this (shipper's) copy of this non-negotiable waybill and warrant that information contained on this waybill is true and correct.

Truck No: 1445/0-11



48x43x28 = 3
37x46x44 = 3
55x38x38 = 10
58x24x62 = 1
29x31x50 = 10

ANNEXURE

S.No.	Item Description	Quantity	Rate per unit In Rs.	Total Amount in Rs.
1	QSC AMPLIFIER – RMX 4050 HD	1 No	76090	76090.00
2	QSC SPEAKER –ADS 282 H	2 Nos	40998	81996.00
3	QSC SPEAKER –ADS 82 H	10 Nos	19118	191180.00
4	QSC BRACKET –ADI D8	10 Nos	5370	53700.00
5	QSC SPEAKER –ADS 52	4 Nos	9584	38336.00
	Total			441302.00
	CST 12.5%			

M/s.MRH Digital Systems Private Limited,
P.O.Box 4050, 290 Lamington Road,
Mumbai 400 007, India.

197

23



गमो वै मः

Kalakshetra Foundation

191

C:\2009-2010\V.Admin\2. Engineering\i.Plan\d.Sound Equipments\koothambalam.doc

December 7, 2010

M/s.MRH Digital Systems Private Limited,
P.O.Box 4050, 290 Lamington Road,
Mumbai 400 007, India.

Sub: Supplying of Sound Equipments (QSC Products) -Supply order - Reg.
Ref: Your offer No.019/MRHDS/010-11 dated 25.10.2010.

Based on the recommendation given by the consultant M/s.Sound Wizard, Director, Kalakshetra Foundation is pleased to award the supply order for Supplying of Sound equipments (QSC Products) at a total cost of Rs. 4, 41,302/- (Rupees Four lakh forty one thousand three hundred and two only), plus 12.5 % CST, as per the specification, terms and condition, enclosed herewith. This is a firm rate contract. General term and conditions applicable to this order is attached.

The payment will be disbursed after the material is approved and certified by the consultant - M/s.Sound wizard with in a week.

Delivery time – immediate – till 20.12.2010.
Warrant /Guarantee - One year from the date of delivery.

The materials should be delivered at our premises (door delivery) and materials should be covered with Insurance up to Kalakshetra Foundation/Chennai. Freight and Freight insurance will be additional at actual will be paid producing the bills.

The material delivered should be in original packing WITHOUT tampering with the original manufacturer's packing and in good condition.

The above supply order should be effected and completed within the delivery time specified. If the progress of the supply is found to be not satisfactory or the total supply is not completed in all respects as per the schedule as mentioned above, this supply order will automatically cease without notice and without assigning any reason.

Your acceptance of the conditions as indicated above may please be intimated to us within one week after the receipt of this letter by email.

Kindly acknowledge receipt of the letter.

Leela Samson
Director

Founder: Smt Rukmini Devi
Chairman: Justice Sri S. Mohan
Director & Secretary: Ms. Leela Samson



E-mail: admin@kalakshetra.in
Phone: +91-(0)44-24520836/4057/1844
Fax: +91-(0)44-24524359

198

TAX INVOICE



MRH DIGITAL SYSTEMS™
PRIVATE LIMITED

123 Sahakar Industrial Estate, Plot No. 165/6, Navghar Village,
Vasai Road (E) 401 102, Thane District, Maharashtra. Tel: 95250-2392230
Head Office: 290 Lamington Road, Mumbai 400 007.

194

Sold To KALAKSHETRA FOUNDATION THIRUVANMIYUR CHENNAI 600 041 TEL. 0091-0-44-24520836/4057/1844	Bill No. 1445/10-11
	V/
	Date 15.12.10

Purchase Order No.	Despatch Mode & Challan details
P.O.NO.2009-2010/V.ADMIN/2 ENGINEERING/ I.PLAN/D.SOUND EQUIPMENTS/KOOTHAMBALAM.DOC DT: 07.12.10 KIND ATTN:- LEELA SAMSON.	

Article Description	Quantity	Unit Price	Rs.	AMOUNT	P.
DSC AMPLIFIER RMX 4050 SR. NO. 111025118	01 NO.	76090.00	76090.00		
DSC SPEAKER ADS 282 H SR. NO. LC-7130021, LH-9120007	02 NOS.	40998.00	81996.00		
DSC SPEAKER ADS 82 H SR. NO. LDA010174, 182, 175, 173, 183, 135, 176, 160, 188, 185	10 NOS.	19118.00	191180.00		
DSC BRACKET ADI DS	10 NO.	5370.00	53700.00		
DSC SPEAKER ADS 52 SR. NO. ZAA100746, 745, ZK9100529, 530	04 NOS.	9584.00	38336.00		
				441302.00	
				55162.75	
				496464.75	

RS.: FOUR LACS NINETY SIX THOUSAND FOUR HUNDRED SIXTY FOUR & SEVENTY FIVE PAISE ONLY.

All the equipments listed above have been received and they have been in good working condition except 1 no. ASD 282HT to send back (replaced) and stored in R&D Room. 13/01/11

For **SOUND WIZARD**
Sounid Wizard
Authorized Signatory

VAT T.I.N. 27150292757V Dt. 01-04-2006	Service Tax No. AAACM3576CST001	TOTAL
C.S.T. T.I.N. 27150292757C Dt. 01-04-2006	IT PAN No. AAACM3576C	E.&O.E.

I/ We hereby certify that my / our registration certificate under the Maharashtra Value Added Tax Act, 2002 is in force on the date on which the sale of the goods specified in this Tax Invoice is made by me/us and that the transaction of sale covered by this Tax Invoice has been effected by me/us and it shall be accounted for in the turnover of sales while filing of return and the tax

Subject to Mumbai Jurisdiction

For **MRH DIGITAL SYSTEMS (P) LTD.**

199

Ami Tu.

36

F.O
3/3/11

REGISTERED WITH ACK. DUE

प्राप्ति स्वीकृति (रसीद) ACKNOWLEDGEMENT

• एक रजिस्ट्री पत्र/पोस्टकार्ड/पैकेट/पार्सल प्राप्त हुआ

• Received a Registered Letter/Postcard/Packet/Parcel
Insured

पाने वाले का नाम
Addressed to (Name)

M/S E & E Systems (India) Pvt Ltd
14, Bhattarahalli
Old Madras Road
Near Garden City College
K.R. Puram, Bangalore - 4

† बीमा का मूल्य (रुपयों में)
† Insured for Rupees

REGISTERED WITH ACK. DUE

आर.पी.-54
R.P.-54

भारतीय डाक विभाग
DEPARTMENT OF POSTS, INDIA

प्रेषक डाकघर
की नाम मोहर
Name stamp of
office of posting

8405211000

KALAKSHETRA FOUNDATION
THIRUVANMIYUR,
CHENNAI-600 041

भेजने वाले
का पता
Sender's

200

MTC

REGISTERED WITH ACK. DUE

प्राप्ति स्वीकृति (रसीद) ACKNOWLEDGEMENT

* एक रजिस्ट्री बीमा पत्र/पोस्टकार्ड/पैकेट/पार्सल प्राप्त हुआ

* Received a Registered Insured Letter/Postcard/Packet/Parcel

पाने वाले का नाम
Addressed to (Name)

M/s. MAH Digital Systems Private Limited, P.O. Box 290, Lamington Road, Mumbai - 400007, India.

† बीमा का मूल्य (रुपयों में)
† Insured for Rupees

वितरण की तारीख / Date of delivery

MRH DIGITAL SYSTEMS PRIVATE LIMITED

290 Lamington Road, Mumbai - 400007

* अनावश्यक को काट दिया जाए
* Score out the matter not required.
† केवल बीमा वस्तुओं के लिए
† For Insured articles only

पाने वाले के हस्ताक्षर / Signature of addressee

REGISTERED WITH ACK. DUE

आर.पी.-54
R.P.-54

भारतीय डाक विभाग
DEPARTMENT OF POSTS, INDIA

प्रेषक डाकघर की नाम मोहर
Name stamp of office of posting

[Name stamp area]

KALAKSHETRA FOUNDATION
THIRUVANMIYUR,
CHENNAI-600 041

भेजने वाले का पता
Sender's Address

[Postmark: CHENNAI 08.12.11]

पिन/PIN

[PIN code boxes]

MGIPCB-28 PSD/CBE/01-01-10-40201007

201



MRH DIGITAL SYSTEMS™ PRIVATE LIMITED

123 Sahakar Industrial Estate, Plot No. 165/6, Navghar Village,
Vasai Road (E) 401 102, Thane District, Maharashtra. Tel: 95250-2392230
Head Office: 290 Lamington Road, Mumbai 400 007.

95

Sold To
KALAKSHETRA FOUNDATION
THIRUVANMIYUR CHENNAI 600 041
TEL 0091-0-44-24520836/4057/1844

Bill No. **V/** 1445/10-11

Date 15.12.10

Purchase Order No.

Despatch Mode & Challan details

P.O.NO.2009-2010/V.ADMIN/2 ENGINEERING/
I.PLAN/D.SOUND EQUIPMENTS/KOOTHAMBALAM.DOC
DT: 07.12.10
KIND ATTN: LEELA GANSON.

Article Description	Quantity	Unit Price	Rs.	AMOUNT	P.
OSC AMPLIFIER RMX 4050 SR. NO. 111025118	01 NO.	76090.00	76090.00	76090.00	
OSC SPEAKER ADS 282 M SR. NO. LC-7130021, LH-9120007	02 NOS.	40998.00	81996.00	81996.00	
OSC SPEAKER ADS 82 M SR. NO. LDA010174, 182, 175, 173, 183, 135, 176, 160, 188, 185	10 NOS.	19118.00	191180.00	191180.00	
OSC BRACKET ADI DB	10 NO.	5370.00	53700.00	53700.00	
OSC SPEAKER ADS 52 SR. NO. ZAA100746, 745, ZK9100529, 530	04 NOS.	9584.00	38336.00	38336.00	
			441362.00		
ADD: 12.5% CST W/O FORM 'C'			55162.75		
			496464.75		

RS.: FOUR LACS NINETY SIX THOUSAND FOUR HUNDRED SIXTY FOUR & SEVENTY FIVE PAISE ONLY.

All the equipments listed above have been received and they have been in good condition and stored in R&D room. Except - (X) 1x ASD 282HT to send back

VAT T.I.N. 27150292757V Dt. 01-04-2006
C.S.T. T.I.N. 27150292757C Dt. 01-04-2006

Service Tax No. AAACM3576CST001
IT PAN No. AAACM3576C

TOTAL E.&O.E.

For SOUND WIZARD
Sound Wizard

For MRH DIGITAL SYSTEMS (P) LTD.

Subject to Mumbai Jurisdiction

I/We hereby certify that my/our registration certificate under the Maharashtra Value Added Tax Act, 2002 is in force on the date on which the sale of the goods specified in this Tax Invoice is made by me/us and that the transaction of sale covered by this Tax Invoice has been effected by me/us and it shall be accounted for in the turnover of sales while filing of return and the tax due, if any, payable on the sale has been paid or shall be paid.

Authorised Signatory

202

FOD Cash Memo Annexure

BLUE DART EXPRESS LIMITED

To.
KALAKSHETRA FOUNDATION
TIRURANMIYAR

MAA *253470

Awb No : 54751519933 Date:24/12/2010
Consignor : MRH DIGITAL SYSTEMS PVT LTD

Total Charges : 3902.46

Service Tax : 390.25

Education Cess : 11.71

Grand Total : 4304.00

Service Tax No : M-1V/H/ST/CRK/042

Signature

Name
CONTRACTOR - 706

Emp Code
90706

203

FDD Cash Memo Annexure

BLUE DART EXPRESS LIMITED

To:
KALAKSHETRA FOUNDATION
TIKURANNIYAR

MAN *253470

Awb No : 54751519933
Consignor : MRK DIGITAL SYSTEMS PVT LTD

Date: 14/12/2017

Total Charges	:	3902.46
	:	
Service Tax	:	390.25
Education Cess	:	11.71
	:	=====
Grand Total	:	4304.00

Service tax No : M-IV/H/ST/CRR/042

Signature
Ku

Name
CONTRACTOR - 706

Emp Code
90706

K. Veeramani
9440537650

Received Cash Amount 4304 Rs

Ku

209

NON-NEGOTIABLE AT OWNER'S RISK

Origin	Sc	Dst.	Sc	P/U	W/I	Dox (1)	Code
				✓		Non Dox (2)	

DART SURFACELINE
FOD
BLUE DART
EXPRESS LIMITED

S Customer Code 235470
H Company _____
I Sender MRH
P Address _____
P _____
E City _____ Pin 601210
R Tel. Vadai Mob _____
 E-mail: _____

C Consignee Code _____
O Company _____
N Attn Kalakeshera Foundation
S Address _____
I _____
G _____
N City _____ Pin 600011
E Tel. Kinnai Mob _____
E E-mail: _____

No. of Pkgs. _____
 Decl Value (Rs) _____ P
 Pieces _____
 Dimensions in (Cms) Length _____ Breadth _____ Height _____
 Dim Wt. (kg.): _____
 Act Wt. (kg.): _____
 No. of Delivery Challans. _____

P/U Date _____ Time _____
 Ship Date _____ PUR# _____
 P/U Emp# _____
 Sign _____
 Name: _____

Pcs/Out of	Description (Said to contain)	Shipper's Reference No.	Code	Details	Amount(Rs.)
<u>25</u>	<u>Sainyam 9710778893</u>	<u>24520036 / 24524357</u>	<u>2</u>	Freight <u>hala sheta</u>	
				RAS Charge	
				Fuel Surcharge	
				AWB Fee	
				FOV Charge	
				Owner Risk	
				FOV Charge	
				Ins. Arrangement	
				VCHC Charge	
				DC Charge	
				FOD Charge	
				Other Charge	
				TOTAL	
				Service Tax plus Cess	
				GRAND TOTAL	

*In case this consignment contains anything of value, the company recommends insurance of the same. The company's liability on this shipment is limited to Rs 5,000/- or cost of reconstruction whichever is lower.

I/We hereby agree to the terms and conditions set forth on the reverse of this (shipper's) copy of this non-negotiable waybill and warrant that information contained on this waybill is true and correct.

This shipment does not contain any cash or equivalent.

Shipper's Name _____ Shipper's Sign _____

ESA CODE _____

Special Instructions _____



54751519933

PLEASE QUOTE THE ABOVE NUMBER IN FUTURE CORRESPONDENCE

Transaction Type _____ Code _____ FOC _____ Code _____ Cash Memo# _____

I/We hereby agree that the Freight on Delivery (FOD) has my/our consent and will be paid by the Consignee along with Service Charges as applicable at the time of delivery

Name _____

Shipper's Sign _____

ACCOUNTS COPY

Track this Air Waybill at www.bluedart.com

207



Works kalakshetra <works@kalakshetra.in>

QSC products

Works kalakshetra <works@kalakshetra.in>

Fri, Dec 24, 2010 at 5:17 PM

To: Fabien <fabien@soundwizard.net>

Dear Didier and Fabien,

QSC products materials have been delivered to kalakshetra foundation by M/s.MRH digital pvt ltd from MUMBAI.

for information please. Kindly know me, your visit to kalakshetra for testing and certifying the materials andfor payment.

Affixing the seal may be arranged

warm regards

v.srinivasan
Kalakshetra

Ops team
M/s. MRH digital pvt ltd
on 27.12.10
201

201



Works kalakshetra <works@kalakshetra.in>

QSC products - Payment - Reg.

Works kalakshetra <works@kalakshetra.in>

Thu, Jan 13, 2011 at 12:40 PM

To: unni@mrhdigital.com, rupali@mrhdigital.com

Cc: Fabien <fabien@soundwizard.net>, Didier <didier@soundwizard.net>

Sir/s,

We are receipt of your materials vide invoice No.1445/10-11 dated 15.12.2010.

The sound consultant M/s.Sound Wizard /Fabien checked and the materials sent by you.

It is submitted that one of the equipment sl.no.2 as per the invoice, Speaker ADS 282 H - 2 No, one no is correct and second carton box equipment was Speaker ADS 282 HT which was not certified by the consultant and remarked to sent back to you for immediate replacement.

Hence you are requested to arrange to replace above said speaker item at the earliest at your cost please.

Kindly provide your banker name, and Account No and banker IFSC Number, the payment will be made through bank. Not by cheque.

Warm regards

V.sRinivasan.

210

203

Kindly provide your banker name, and Account No and banker IFSC Number, the payment will be made through bank. Not by cheque.

Warm regards

V.sRinivasan.

211

282412
204

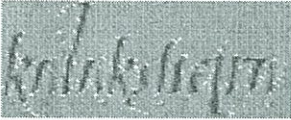

Works kalakshetra <works@kalakshetra.in>

Re: QSC products - Payment - Reg.

ajit thakur <ajitcalibre@gmail.com>

Thu, Jan 20, 2011 at 6:59 PM

To: Fabien Bontems <fabien@soundwizard.net>, works@kalakshetra.in

Cc: Didier Weiss <didier@soundwizard.net>

dear sir;

KIND ATTN : MR. SRINIVASAN.V.

we wish to inform you that we have sent one no of qsc speaker ads 282h thru blue dart courier their dckt no : 0129821976 dt 19/1/11 on freight paid basis – surface mode to you.

please acknowledge the same once you receive the speaker . also we will let you know how to send the incorrect speaker back to us.

our banking instructions are as under :

name: mrh digital systems pvt.ltd.
bank : bank of baroda; opera house branch
a/c type : cash credit .
a/c no : 04090500000016.
ifsc code : BARBOOPERAH

PLEASE NOTE THAT THE FIRST 0 IS NUMERICAL ZERO & THE SECOND O IS ALPHABETICAL O

THANKING YOU;
FOR MRH DIGITAL SYSTEMS PVT.LTD.
AJIT THAKUR

On Sat, Jan 15, 2011 at 12:23 PM, Fabien Bontems <fabien@soundwizard.net> wrote:

FYI

----- Original Message -----

Subject:QSC products - Payment - Reg.

Date:Thu, 13 Jan 2011 12:40:37 +0530

From:Works kalakshetra <works@kalakshetra.in>

To:unni@mrhdigital.com, rupali@mrhdigital.com

CC:Fabien <fabien@soundwizard.net>, Didier <didier@soundwizard.net>

Sir/s,

We are receipt of your materials vide invoice No.1445/10-11 dated 15.12.2010.

The sound consultant M/s.Sound Wizard /Fabien checked and the materials sent by you.

It is submitted that one of the equipment sl.no.2 as per the invoice, Speaker ADS 282 H - 2 No, one no is correct and second carton box equipment was Speaker ADS 282 HT which was not certified by the consultant and remarked to sent back to you for immediate replacement.

Hence you are requested to arrange to replace above said speaker item at the earliest at your cost please.

212

205



E&E SYSTEMS

Date: 12/01/2011

To Whomsoever it May concern

This is to Certify that we are sending this parcel to the below mentioned address through TNT Courier by AIR MODE,

We are sending this material AS A WARRENTY REPLACEMENT SPARE PART
This is not meant for sale. The value of the material is Rs, 800/-

To,

KALAKSHETRA FOUNDATION
THIRUVANMIYUR
CHENNAI - 600041
PH: 044-24520836 / 4057 / 1844
Contact Person: MS. LEELA SAMSON

Thanks & Regards



For E&E Systems-India

A handwritten signature in black ink.

213

E&E Systems (India) Pvt Ltd

EVOMA Business Park,
#14, Bhatrahalli Old Madras Road
KR Puram, Bangalore – 560049, India
Tel. : +91 (0) 80 41903883 / 80 / 81 / 79
Fax : +91 (0) 80 41903005

206



E&E SYSTEMS

Date: 12/01/2011

To Whomsoever it May concern

This is to Certify that we are sending this parcel to the below mentioned address through TNT Courier by AIR MODE,

We are sending this material AS A WARRENTY REPLACEMENT SPARE PART
This is not meant for sale. The value of the material is Rs, 800/-

To,

KALAKSHETRA FOUNDATION
THIRUVANMIYUR
CHENNAI - 600041
PH: 044-24520836 / 4057 / 1844
Contact Person: MS. LEELA SAMSON

Thanks & Regards



For E&E Systems India

A handwritten signature in black ink.

214

E&E Systems (India) Pvt Ltd

EVOMA Business Park,
#14, Bhatrahalli Old Madras Road
KR Puram, Bangalore - 560049, India
Tel. : +91 (0) 80 41903883 / 80 / 81 / 79
Fax: +91 (0) 80 41903005

207



E&E SYSTEMS

Date: 12/01/2011

To Whomsoever it May concern

This is to Certify that we are sending this parcel to the below mentioned address through TNT Courier by AIR MODE,

We are sending this material AS A WARRENTY REPLACEMENT SPARE PART
This is not meant for sale. The value of the material is Rs, 800/-

To,

KALAKSHETRA FOUNDATION
THIRUVANMIYUR
CHENNAI - 600041
PH: 044-24520836 / 4057 / 1844
Contact Person: MS. LEELA SAMSON

Thanks & Regards,



For E&E Systems India

(215)

E&E Systems (India) Pvt Ltd

EVOMA Business Park,
#14, Bhatrahalli Old Madras Road
KR Puram, Bangalore – 560049, India
Tel. : +91 (0) 80 41903883 / 80 / 81 / 79
Fax : +91 (0) 80 41903005

1. Sender's Account Number 955944
 2. Invoice to Receiver SE **LIABLE FOR UNPAID CHARGES**
 Receiver's account number

3. Customer Reference (Information you would like on the invoice (if required))

4. From (Collection Address)
 Name: ETE Supplies
 Address: 14 Bradfordhall, old Hednesham

City: BRADFORD Postal / Zip Code: 60049
 Contact Name: Good Tel. No.:

5. To (Receiver)
 Name: Katka Koflerova
 Address: Trhy u mlynu 60041

City: BRNO Postal / Zip Code: 60041
 Contact Name: Good Tel. No.:

6. Delivery Address
 Name: Katka Koflerova
 Address: Trhy u mlynu 60041

City: BRNO Postal / Zip Code: 60041
 Contact Name: Good Tel. No.:

7. Dangerous Goods
 this consignment contain any dangerous goods? Yes No
 If Yes, call our Customer Service. 318
 Received by TNT 318
 Date: 10/11/11 Time: 10:00

Sending Depot 001 Receiving Depot 250



DO 948 297 463 WW

Please quote this number if you have an enquiry.



8a. Services

- Special Express
- 9:00 Express
- 10:00 Express
- 12:00 Express
- Economy Express
- Air-Freight

Documents Non-Documents

8b. Options

- Priority
- Enhanced Liability
- Rs.
- FTC
- VTC

9. Special Delivery Instructions

DISN MAA 096609

10. Goods Descriptions

General Description	Number of Items	Weight Kilos	Weight Grams	Dimensions Length	Width	Height
<u>MAACENY</u>	<u>01</u>					
<u>DEPARTMENT</u>						
<u>SPACE PAAT</u>						
Sat No.	Total					
	<u>01</u>	<u>00</u>				

11. Service Sticker

RECEIVER'S COPY

4
 (216)

209

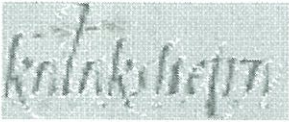

Works kalakshetra <works@kalakshetra.in>

QSC speaker replacement - reg

Works kalakshetra <works@kalakshetra.in>
To: unni@mrhdigital.com, rupali@mrhdigital.com

Mon, Jan 24, 2011 at 12:43 PM

Sir,

We received email that the replacement qsc speaker sent through Blue dart couier and their dckt no : 0129821976 dt 19/1/11. The speaker has not received till by 1.00 pm today.

On enquiry that the docket no given is incorrect. please check it and confirm by return email.

expecting your reply.

warn regards
V.srinivasan

217
18



2109

MRH DIGITAL SYSTEMS™ PRIVATE LIMITED

123 Sahakar Industrial Estate, Plot No. 165/6, Navghar Village,
Vasai Road (E) 401 102, Thane District, Maharashtra.

Date 19th Jan 2011

To,
Kala Kshetrya Foundation
Thiruvanniyur,
Chennai - 600 004

Kind Attn Mr. Shrinivasan
Tel No 097104 78893

TO WHOM SO EVER IT MAY CONCERN.

This is to certify that the parcel sending thru your blue dart is being on to.

As per above address

Containing 01 nos. of QSC speaker ADS 7S2 H we mentioned speaker we are sending
is for demo purpose & not for sale. This transaction commercial value as such the
approximate declared value for this speaker is not more than Rs 49998 00
(FOURTY THOUSAND ONLY) *M*

Thanking You.

For MRH Digital Systems Pvt Ltd

Ajit Thakur

CST No.27150292757 C Dated 01.04.2006.

MRH DIGITAL SYSTEMS
PRIVATE LIMITED
123 Sahakar Industrial Estate,
Plot No. 165/6, Navghar Village,
Vasai Rd. (E)-401102, Thane Dist. Maharashtra

17
218

210



MRH DIGITAL SYSTEMS™ PRIVATE LIMITED

123 Sahakar Industrial Estate, Plot No. 165/6, Navghar Village,
Vasai Road (E) 401 102, Thane District, Maharashtra.

Date 19th Jan 2011

To,
Kala Kshetria Foundation
Thiruvanniyur,
Chennai - 600 004

Kind Attn Mr. Shrinivasan
Tel No 097104 78893

ph. 09.444-24520836.

TO WHOM SO EVER IT MAY CONCERN.

This is to certify that the parcel sending thru your blue dart is being on to.

As per above address

Containing 01 nos of QSC speaker ADS 282 H we mentioned speaker we are sending
is for demo purpose & not for sale. This transaction commercial value as such the
approximate declared value for this speaker is not more than Rs 40,998 00

(FOURTY THOUSAND ONLY)

Thanking You.

For MRH Digital Systems Pvt Ltd

Ajit Thakur

CST No.27150292757 C Dated 01.04.2006.

MRH DIGITAL SYSTEMS
PRIVATE LIMITED
123 Sahakar Industrial Estate,
Plot No. 165/6, Navghar Village,
Vasai Rd. (E)-401102, Thane Dist. Maharashtra

219

Product CODE : <input type="text"/>		Origin	Sc	Dst.	P/U	W/I	Doc (1)	Code
Customer Code : 253470		CONSIGNEE						
Company : MRH		Company : Rada Kshetrya						
Sender : Navghar		Attn : Thiruvanniyur						
Address : Vasai		Address : Chennai						
City : Vasai Pin : 401210		City : Chennai Pin : 600004						
Tel. : Mob :		Tel. : Mob :						
E-mail :		E-mail :						

P/U Date	Time	Pcs/Out of	Description (Said to contain)	Shipper's Reference No.	Code	Details	Amount (Rs.)
19/11		1	Comp. Goods		2	Freight	
Ship Date	PUR#					RAS Charge	
P/U Emp#						Fuel Surcharge	
Sign						AWB Fee	
Name:						FOV Charge/ Owner's risk	

Received shipment in good condition. I/We agree to pay all charges including customs, duties, taxes & octroi as applicable		Del. Date	Time
CONSIGNEE'S SIGN		Del. Emp#	Sign
Name		Name	
Remarks		Name	

Transaction Type		Code	FOC	Code	Cash Memo#
Cash(1) Credit(2) Credit Card(3)					
BCN BTP NO		PLEASE QUOTE THE ABOVE NUMBER IN FUTURE CORRESPONDENCE			
Shipper's Name		Shipper's Sign			
ESA CODE		ODA			
Special Instructions		SUB PRODUCT CODE			

Attached Documents:		MOD VAT	PERMIT
		<input type="checkbox"/>	<input type="checkbox"/>

Freight	
RAS Charge	
Fuel Surcharge	
AWB Fee	
FOV Charge/ Owner's risk	
FOV Charge/ Ins. Arrangement	
VCHC Charge	
DC Charge	
ODA Charge	
Other Charge	
TOTAL	
Service Tax plus Cess	
GRAND TOTAL	

Track this air waybill at www.bluedart.com NON-NEGOTIABLE-AT OWNER'S RISK

DART SURFACELINE

BLUE DART EXPRESS LIMITED

No. of Pkgs: 1

Decl Value :Rs P

Pieces Length Breadth Height

Dim Wt. (kg.): 15kg

Act Wt. (kg.): 15kg

No. of Delivery Challans.

50129821976

PLEASE QUOTE THE ABOVE NUMBER IN FUTURE CORRESPONDENCE

Transaction Type Code FOC Code Cash Memo#

Cash(1) Credit(2) Credit Card(3)

BCN BTP NO

SELECTED 0003

Superbrand

INDIA 2009-10

CONSUMER VALIDATED

Attached Documents: MOD VAT PERMIT

CONSIGNEE'S COPY

KALAKSHETRA FOUNDATION

THIRUVANNIYUR, CHENNAI - 600 041.

PHONE : 2452 0836 / 2452 4057 / 2452 4359 (FAX)

NON RESILIENT PLASTIC MATERIAL

GATE PASS

As verified Sound Consultant
Sound with good value

No. 1386

Date 25/11/11

2020

1. Particulars of article/material/
goods sent out
QSC Speaker ADS
282 HT - 1 no.

2. Unit's Name
Central office, V.R.

3. Party's Name
M/S. MRH DIGITAL
SYSTEM PVT. Ltd.
Chennai

4. Date and Time
25/11/2011 - 2.30P

Signature of the Representative
25/11/11

B.V. Veludend
TN 09 AE
9895.

Supervisor

Further, the sound consultant M/s.Sound Wizard decided to the change of supplier and given direction to place the balance materials supply order on M/s.MRH Digital systems with change of specification, at a total cost of Rs.4, 96,465/- ^{due to the return of materials} freight charges extra, after terminating the supply order of M/s.E& E systems / Bangalore. The termination of supply order to M/s. M/s.E & E systems /Bangalore was dispatched on 8.11.2010.

Page 18:
2184

M/s.MRH Digital systems delivered the cabling materials to the Foundation. Our consultant M/s.Sound Wizard / representative Mr.Fabien checked and verified the delivered packing materials and stated that 'all the materials listed in the invoice have been received and they have been in good working condition and stored in R&D room and recommended to release the payment' in the invoice copy of the supplier.

Page 195
reverse

Payable to M/s.MRH Digital systems
Vide Invoice No.V/1445/10-11 dated 15.10.2010

Rs.4,96,464.75/-
(in words 12,77,657) | Page 195

Paid to M/s.Blue Dart Express limited
Towards freight charges
Vide bill No.*253470 dated 24.12.2010(AWD No.54751519933
This amount may be reimbursed to me (V.Srinivasan)

4,304.00/- | Page 197

Total 5,00,768.75

The supplier M/s.MRH Digital systems, banker details

Banker Name: BANK OF BARODA
Account Name MRH Digital systems Pvt Ltd
Account No 04090500000016
IFSC code BARB00PERAH

email again from the supplier - | Page 204

If approved, the payment of Rs.5,00,768.75/- (Rupees Five lakh seven hundred sixty eight and paise seventy five only) may be paid to the above ,supplier M/s.MRH DIGITAL SYSTEMS PVT LTD and ~~V.srinivasan~~ towards final bill payment for supply of QSC products – sound equipments for the Koothambalam work.

[Signature]
AO 10/12/11

[Signature]
15/10/2011

Deputy Director

[Signature]
15/12

Director.

[Signature]
15/12

[Signature]
EO

221

C:\ 2010-20110\V.Admin\2. Engineering\i.Plan\d.Sound systems\koothambalam.doc	February 10, 2011
---	-------------------

Sub: Koothambalam –Sound Equipments – EAW and Audix products (Changed as QSC Products)– payment - Approval of - Reg.

- Ref: i) Approval dated 6.11.2009 (placed below please) P-2 -10
 ii) Change of suppliers approval note dated 15.02.2010 / 18.02.2010 P-115
 iii) Sound consultant M/s.Sound Wizard email dated 26.10.2010 P -159
 iv) Works committee member P.T.Krishnan note with remarks dated 12.11.10– P-183.
 v) Justification Note sent by the M/s.Sound Wizard email dated 16.11.2010 P-184&176
 vi) our supply order dated December 7, 2010 P – 190,191

Chronology

As per the Works Committee approval, the supply order for supplying of EAW and Audix products was awarded to M/s.Aditya InfoTech / Chennai at a total cost of Rs.61, 70,870/- Nett. The part of shipment and equipment was supplied by the agency on 25.11.2009 for a value of Rs.36, 98,944/-. The payment was made to the supplier. Balance equipment supply was not supplied by M/s.Adityainfotech due to uncertainty. The sound consultant decided to the change of supplier and given direction to place the balance materials supply order on two suppliers namely M/s.E& E systems and M/s.Sennheiser India at a total cost of Rs.19,27,488/- and Rs.6,73,047/- respectively after adhering the following procedure.

| Page 1 & 2
| Page 2 & 2
| Page 37
| Page 36

- The termination of contract / Supply order, was issued to the agency M/s.Aditya info Tech Limited, Nungambakkam, based on the recommendation / remarks given by the consultant M/s.Sound wizard. The receipt of the letter of termination of supply order (Balance materials) was received from the postal acknowledgement on 29.02.2010.
- Further, the reason for Non-supply of the balance materials as per the work order from M/s.Aditya InfoTech ltd has been received.
- The fresh quotations for the supplying balance sound equipments (as per the list) as per the selected models and changed specifications equipments were called by the consultant from various manufactures and brand, and the quotes were received by the Foundation as directed.

| Page 40, 49
| Page 66
| Page 60-61
69, 110
| Page 115, 11

Based on the approval of works committee, the supply order for supplying Micro phone was issued and M/s.Senheiser India Pvt ltd on 24.3.2010. The supplier delivered all the materials as per the supply order brand and specification. The payment was made to the supplier.

| Page 97-1
| Page 134

The supply order for supplying speaker equipments was issued and M/s. E& E systems / Bangalore at a total cost of Rs.19,27,488/-, freight and insurance cost extra. The part of shipment and equipment was supplied by the M/s. E& E systems / Bangalore on 16.8.2010 for a value of Rs.13, 72,785/-. The payment was made to the supplier.2

| Page 122
| Page 146, 11

2122

217



Works kalakshetra <works@kalakshetra.in>

Excess payment - refund - requested - reg.

Works kalakshetra <works@kalakshetra.in>
To: unni@mrhdigital.com, rupali@mrhdigital.com

Wed, Mar 23, 2011 at 12:30 PM

Dear sir,

we paid an amount of Rs.5,00,768.75/- against your bill No.V/1445/10-11 dated 15.10.2010 value of Rs.4,96,464.75. An amount of Rs.4,304 was paid as excess to you by mistake.

The amount of Rs.4,304/- has to be paid to me (V.Srinivasan) towards paid freight charges for taking the delivery from the Blue dart expresss, the materials sent by you.

Please kindly refund the excess money (Rs.4304) with the following.

Please send the DD for Rs.4304/- in my name V.srinivasan payable at chennai.

OR

Please send the DD for Rs.4304 in favour of Kalakshetra Foundation payable at chennai

OR

Please make the bank transfer in the kalakshetra Foundation account - details

Canarabank - Thiruvanmiyur branch
Account No.2649101001719
type of account - SB
IFSC code No - CNRB0002649
amount Rs. 4304

Kindly do the needful at the earliest before 26 March 2011. We are under pressure to complete our account by March 31st 2011.

Please sent the email confirmation

V.sRinvasan
Kalakshetra.

225

218



Works kalakshetra <works@kalakshetra.in>

Speaker clamp - Pending - reg

Works kalakshetra <works@kalakshetra.in>

Wed, Mar 23, 2011 at 12:49 PM

To: Fabien <fabien@soundwizard.net>, Didier <didier@soundwizard.net>

Hi Fabien,

How are you.

DEC from USA, shipment already lifted at tempest lighting and expected to reach chennai airport by saturday and the material will be lift from the chennai cargo within two days positively..

Meanwhile, the one pending materials for speaker clamp yet to be received from M/s.E& E bangalore and payment for the M/s.E&E for Rs.35,000/- towards supplied clamps is pending.

please guide me, shall I process the payment for the supplied speaker clamps to M/s.E&E or wait for the balance clamp and then payment to M/s.E&E. Please reply by email.

All your bill claim (Transportation charges) and payment was made to your account by bank transfer except current one which is received No.10-817-T43 for Rs.6618/- For inforamtion please.

Warm regards

V.Srinivasan.

218

Draft for Approval please

KALAKSHETRA FOUNDATION.

Dt:29-03-2011.

M/s E & E Systems (India) Pvt. Ltd,
14,Bhattrahalli, Old Madras Road,
Near Garden City College,
K.R.Puram,
Bangalore - 560 049.

Sir,

Sub:- Koothambalam Sound equipments - Speaker Systems

Ref: 1) Our Work Order No.C:\2009- 2010\V.Admn\2.
Engineering\i.Plan\d.sound\d.sound
systems\koothambalam.doc Dated 19-08-2010. — F.147

2)E.mail Works.kalkashetra <works@kalskshetra.in dated
23.03.2011 sent to M/s.Sound Wizard, Auroville - 605 101. — F.218

Kindly arrange to supply the balance speaker clamp as requested by
M\s.Sound Wizard to Kalakshetra Foundation at the earliest. This is urgently *required*
~~needed~~ for koothambalam sound system work.

This is in line with the approval of Bangalore Auditor

Yours faithfully,

Director.
40.

Copy to M/s Sound Wizard, No.9, Shakti Area, Auroville - 605 101.
(near Pondicherry)

[Signature]
EO
25/3/11
AO

[Signature]
CAO

Dy. Director.

[Signature]

Director.

[Signature]

225

KALAKSHETRA FOUNDATION.

Dt:30-03-2011.

M/s E & E Systems (India) Pvt. Ltd,
14,BhattraHalli, Old Madras Road,
Near Garden City College,
K.R.Puram,
Bangalore – 560 049.

Sir,

Sub:- Koothambalam Sound equipments – Speaker Systems

Ref: 1) Our Work Order No.C:\2009- 2010\V.Admn\2.
Engineering\i.Plan\d.sound\d.sound
systems\koothambalam.doc Dated 19-08-2010.

2)E.mail Works.kalkashetra <works@kalkashetra.in dated
23.03.2011 sent to M/s.Sound Wizard, Auroville – 605 101.

Kindly arrange to supply the balance speaker clamp as requested by
M\s.Sound Wizard to Kalakshetra Foundation at the earliest. This is urgently
required for koothambalam sound system work.

This is issued with on approval of competent authority.

Yours faithfully,

 
Administrative Officer.

 Copy to M/s Sound Wizard, No.9, Shakti Area, Auroville – 605 101.
(near Pondicherry)

2

226



E&E SYSTEMS

DATE: 24-06-2011

To Whomsoever it May concern

This is to Certify that we are sending the parcel to the below mentioned address through **PROFESSIONAL COURIER** .

We are sending this material to the below mentioned party after **WARRENTY SERVICE**. This is not meant for sale.

The value of the material is Rs. 500/-

To,

**Kalakshetra Foundation
Thiruvanmiyur
Chennai - 600 041
Tel: 044 - 24520836 / 4057 / 1884
Fax: 044 - 24524359**

For any clarifications please contact us.

Thanks & Regards.



Monica

For E&E Systems India

*Fahmy
08/07/2011*

E&E Systems (India) Pvt Ltd

No. 69, 5th Main, 3rd Cross, OMBR Layout
Lalbahdur Nagar, B.Channasandra,
Chikkabanaswadi, Bangalore - 560043, India
Phone : +91 (0) 80 42083562
Website : www.enesystemsindia.com

027

8

 **Kalakshetra Foundation.pdf**
208K

7228

finally,

we have received first time - 2 nos clips

2nd time - 2 nos clips

total 4 nos

v.srinivasan.

On Tue, Feb 28, 2012 at 2:57 PM, Fabien Bontems
<Fabien@soundwizard.net> wrote:

So what is the number?

Best Regards,

Fabien Bontems

System Design & Optimization

Sound Wizard - Acoustics AV Design Consulting

#9 Shakti Area, Auroville 605101 (near Pondicherry), TN, India

+91 413 2622 480, 482, 659, +91 9751 42 0678

fabien@soundwizard.net [] www.soundwizard.net

On 28-Feb-2012, at 1:57 PM, Works kalakshetra wrote:

yes please

v.srinivasan

On Mon, Feb 27, 2012 at 11:33 AM, Fabien Bontems
<Fabien@soundwizard.net> wrote:

Dear Srinivasan,

I am still waiting to clarify the number of clips you have.
Kindly revert asap.

Best Regards,

Fabien Bontems

System Design & Optimization

Sound Wizard - Acoustics AV Design Consulting

#9 Shakti Area, Auroville 605101 (near

Pondicherry), TN, India

+91 413 2622 480, 482, 659, +91 9751 42 0678

fabien@soundwizard.net [] www.soundwizard.net

429



Works kalakshetra <works@kalakshetra.in>

Clips

Fabien Bontems <Fabien@soundwizard.net>

Tue, Apr 10, 2012 at 3:05 PM

To: Works kalakshetra <works@kalakshetra.in>

Cc: Leela Samson Samson <leelasamson@gmail.com>, Kumbha Young Grenier <kyg@soundwizard.net>, Didier Weiss <didier@soundwizard.net>

Dear Srinivasan,

E&E systems are putting pressure on me for their payment. They have sent me the courier receipt for the clips. I am attaching them to this mail. Please recheck once more. I'm also sure I have cleared 6 clips so far. Kindly get back to me asap.

Best Regards,

Fabien Bontems

System Design & Optimization

Sound Wizard - Acoustics AV Design Consulting

#9 Shakti Area, Auroville 605101 (near Pondicherry), TN, India

+91 413 2622 480, 482, 659, +91 9751 42 0678

fabien@soundwizard.net [] www.soundwizard.net

On 01-Mar-2012, at 11:48 AM, Works kalakshetra wrote:

Hi Fabien,

it is confirmed that we have received 4 nos only .

v.srinivasan

On Thu, Mar 1, 2012 at 11:43 AM, Fabien Bontems <Fabien@soundwizard.net> wrote:

Dear Srinivasan,

I'm sure we have received at least 6 clips. I just wasn't sure wether the last 2 had come.

Can you check again?

Best Regards,

Fabien Bontems

System Design & Optimization

Sound Wizard - Acoustics AV Design Consulting

#9 Shakti Area, Auroville 605101 (near Pondicherry), TN, India

+91 413 2622 480, 482, 659, +91 9751 42 0678

fabien@soundwizard.net [] www.soundwizard.net

On 01-Mar-2012, at 11:38 AM, Works kalakshetra wrote:

Hi fabien,

sorry for the delay for furnishing the details,

I have to check physically and give correct information.

WRITE SECTIONS ARE MANDATORY. PLEASE COMPLETE IN CAPITALS AND PRESS HARD.

1. Sender's Account Number 95584

2. Invoice to Receiver SENDER LIABLE FOR UNPAID CHARGES
 Cross and provide receiver's account number →
 Box or call Customer Service for correct account details

3. Customer Reference (Information you would like on the invoice (if required))

4. From (Collection Address)

Name: E.E. Syetres
 Address: 14 Bhathrahalli, Old Madras

City: BLR Postal / Zip Code: 560049

Contact Name: _____ Tel. No.: _____

CST/ST/TIN/VAT No. _____

5. To (Receiver)

Name: Kalakesheta Foundation
 Address: Thiruvanniyur

City: CHENNI Postal / Zip Code: 600041

Contact Name: _____ Tel. No.: _____

CST/ST/TIN/VAT No. _____

Delivery Address (if different from receiver's address above)

Name: _____

Address: _____

City: _____ Postal / Zip Code: _____

Contact Name: _____ Tel. No.: _____

CST/ST/TIN/VAT No. _____

7. Dangerous Goods (Cross correct box)

Does this consignment contain any dangerous goods? Yes No

Signature: [Signature] Received by TNT (to be completed by TNT)

Date: 12/01/11 (Day/Month/Year) Time: 12:00

DOMESTIC

Website: www.tnt.com
 Hotline: 1800 423 9999
 Private Network: 6000 9999
 Our Service Tax Reg. No.: KAACT6649KST001

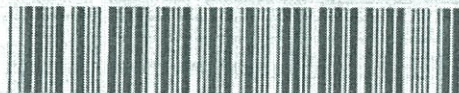

DO 948 297 463 WW

Please quote this number if you have an enquiry.

8a. Services (Cross one box only to select a service)

	Documents	Non-Documents
<input checked="" type="checkbox"/> Special Express	<input type="checkbox"/>	<input type="checkbox"/>
9:00 Express	<input type="checkbox"/>	<input type="checkbox"/>
10:00 Express	<input type="checkbox"/>	<input type="checkbox"/>
12:00 Express	<input type="checkbox"/>	<input type="checkbox"/>
Express	<input type="checkbox"/>	<input type="checkbox"/>
Economy Express	<input type="checkbox"/>	<input type="checkbox"/>
Air Freight	<input type="checkbox"/>	<input type="checkbox"/>

Please contact Customer Service to provide shipment. For contact and service details, please see brochure. If no service is selected, the Express service will be provided and charged.

8b. Options (Cross boxes)

<input type="checkbox"/> Priority Priority handling from pickup to delivery for Express	<input type="checkbox"/>
<input type="checkbox"/> Enhanced Liability For documents and items/contents subject to conditions for returns. Please provide value details.	<input type="checkbox"/>
Rs. _____	
<input type="checkbox"/> FTC	<input type="checkbox"/>
<input type="checkbox"/> VTC	<input type="checkbox"/>

9. Special Delivery Instructions (Reserved for your instructions (if required))

DISN

MAA 274489

10. Goods Descriptions

General Description Please give full details on commercial invoice	Number of Items	Weight		Dimensions		
		Kilos	Grams	Length	Width	Height
<u>WARRANTY</u>	<u>9</u>					
<u>REPLACEMENT</u>						
<u>SPARE PART</u>						
Stat. No. _____	Total	<u>01</u>	<u>00</u>	Consignment subject to volumetric measurement. Please refer to our brochure or call Customer Service.		



11. Service Sticker (For TNT use only)

SENDER'S COPY

Please keep for reference.

231

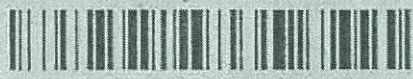
FORMAT NO F12 ISSUE-1

SHIPPER'S DETAILS	BLR/LRP 01	DATE <i>2/1/10</i>	CONSIGNEE'S DETAILS	DESTN.	DDX	NO OF PIECES
					NON-DOX	
MESSERS : ADDRESS : <i>ED</i>			MESSERS : ADDRESS : <i>K. Lakshminath Lingaraipur</i>			WEIGHT
DESCRIPTION OF CONTENTS			DECLARED VALUE : Rs			Kg
I/we certify that this consignment does not contain personal mail of any kind (containing cards, cash, jewellery, mobile phones etc.)			PIN CODE			Gms
SENDER'S NAME			SIGN			DEPT
 BLR835679168 CLIENT CODE			ATTN OF :			CREDIT
			Received by consignee in good order / condition. No claims/complaints will be accepted after 30 days of booking			
 THE PROFESSIONAL COURIERS LRP DOMESTIC & INTERNATIONAL-COURIER & CARGO #36, 1ST FLOOR, BALAJI COMPLEX, HENUR MAIN ROAD, NEAR DIVYA SHANTHI CHURCH, LINGARAJPURA, BANGALORE - 560 084. TEL: 22905790, 25462350 MOB: 9844424909 Track at: www.tpcindia.com			NAME :			Track your consignment at www.tpcindia.com
			SIGN :			
			PHONE :			Received by TPC/BLR
			TIME :			
			TIME :			g.m / p.m
			TIME :			g.m / p.m

PLEASE DO NOT BOOK CASH. IT IS AN OFFENCE. IF IT IS LOST, WE ARE NOT RESPONSIBLE. *ಹಣವನ್ನು ಕಳೆದುಕೊಳ್ಳುವುದು ಅವಧಾರದ* THANKS FOR YOUR VALUABLE PATRONAGE

FORMAT NO F12 ISSUE-1

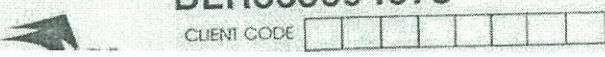
SHIPPER'S DETAILS	BLR/LRP 01	DATE <i>2/1/10</i>	CONSIGNEE'S DETAILS	DESTN. <i>MIAA</i>	DDX	NO OF PIECES
					NON-DOX	
MESSERS : ADDRESS : <i>Egt. Systems</i>			MESSERS : ADDRESS : <i>MACANSHETHA FOUNDATION</i>			WEIGHT
DESCRIPTION OF CONTENTS			DECLARED VALUE : Rs			Kg
I/we certify that this consignment does not contain personal mail of any kind (containing cards, cash, jewellery, mobile phones etc.)			PIN CODE			Gms
SENDER'S NAME			SIGN			DEPT
 BLR835694075 CLIENT CODE			ATTN OF :			CREDIT
			No claims/complaints will be accepted after 30 days of booking. Kindly provide full address and telephone numbers of the addressee for early delivery.			
 THE PROFESSIONAL COURIERS LRP DOMESTIC & INTERNATIONAL-COURIER & CARGO #36, 1ST FLOOR, BALAJI COMPLEX, HENUR MAIN ROAD, NEAR DIVYA SHANTHI CHURCH, LINGARAJPURA, BANGALORE - 560 084. TEL: 22905790, 25462350 MOB: 9844424909 Track at: www.tpcindia.com			NAME :			Track your consignment at www.tpcindia.com
			SIGN :			
			PHONE :			Received by TPC/BLR
			TIME :			
			TIME :			g.m / p.m
			TIME :			g.m / p.m

032

For Telex products, Digital Projector Design products and Draper products, we could not get competitive quotations. However, due to urgency of the work (this work has to be completed before the start of December festival), and the suppliers for other products have been identified, we may go for the supply for these products under the rates given by them, if approved please.

If approved, the suppliers quoted 'L 1' rates for the different products identified by BEC may be approved for issue of supply orders, terms and conditions specified therein.

Administrative approval may please be given for Rs.2.20 crores (Rupees two crore and twenty lakh only) for supply of these products initially. The detail for this administrative approval is given in Annexure II.

The working committee, after viewing the presentation made of various consultants, nominated Sri Ravi Nilakanta as a Consultant Architect for this job. The sound proofing (Acoustic Panel fixing) work will be undertaken through the contractor after obtaining the Bill of Quantities (BOQ) and specification from the consultant.

BEC also includes some sound proofing work, consulting charges and implementation of works to be done to give an inside view of the total amount involved for this work. However, along with sound equipment work, sound proofing works also to be taken side by side in consultation with M/s.Sound Wizard with the reputed contractors in the same field as identified by the consultant

General terms and conditions to be attached to the supply order to be given are also placed below for approval please.

Lala Samson
DIRECTOR 21/10'09

Madhoo Madgal

P.T. Krishnan
P.T.Krishnan 6/11/09
233



रसो वै सः

Kalakshetra
F O U N D A T I O N

C:\2009-2010\IV.Director\2.Official\Works.doc

31 October 2009

Sub: Up gradation of Sound system in Koothambalam - Reg

During the 32nd Governing Board meeting held on 7th April 2009, civil works an Advisory Committee was formed to advise the Director in finalizing various contracts towards works undertaken by Kalakshetra foundation during coming years.

One of the major works, which was highlighted by the Secretary, Ministry of Culture, and New Delhi during the visit to Kalakshetra in September 2009, is up gradation of Sound equipment in Koothambalam. For executing this work, simultaneously along with working committee, M/s. Sound Wizard, an expert in sound equipment installations was also engaged as a expert advisor for this project. The selection of Sound Wizard as an expert advisor for the procurement of this equipment was also made a mention to the Governing Board.

For supply of Audio equipments in Koothambalam, Sound Wizard the technical experts has obtained various quotations for the materials required for the job. Based on the quotations received, we have now formalized Bid Evaluation Criteria (BEC) for supply of audio equipments to Koothambalam. From the BEC, it is proposed to issue supply orders to suppliers whose quotation is 'L 1' and who have been certified by M/s. Sound Wizard as the best supplier for the job at the rates specified in the BEC.

..... 2

234

Founder : Smt. Rukmini Devi Chairman : Justice Sri S. Mohan Former Judge Supreme Court
Director : Ms Leela Samson Member Secretary : Sri R.V. Ramani Governing Board

Kalakshetra Foundation Thiruvanmiyur Chennai 600 041
Tel: 0091-(0)44-2452 0836 / 4057 / 1844 Fax : 0091-(0)44-2452 4359