



कलाक्षेत्र प्रतिष्ठान

KALAKSHETRA FOUNDATION

THIRUVANMIYUR, CHENNAI- 600 041 PH- 044- 24524057 / 0836

\*\*\*\*\*

## NOTICE INVITING TENDER

F.No. A-76/01/2019/KF- Dated- 26.04.2019

Tender Document for the work of  
Providing fabricating & supplying wooden furniture,  
special equipment, repairs to furniture for the visual arts  
section in Kalakshetra Foundation  
Thiruvanmiyur,  
Chennai 600 041

PH- 044 – 24524057 / 0836

E-Mail: [works@kalakshetra.in](mailto:works@kalakshetra.in)

Website: [www.kalakshetra.in](http://www.kalakshetra.in)

\*\*\*\*\*



## कलाक्षेत्र प्रतिष्ठान

### KALAKSHETRA FOUNDATION

THIRUVANMIYUR, CHENNAI- 600 041 PH- 044- 24524057 / 0836

\*\*\*\*\*

Kalakshetra Foundation, an Autonomous Body under the Ministry of Culture, Govt. of India, invites sealed tenders, in the enclosed format from the registered contractors (CPWD/State PWD/Railways/MES/BSNL/Reputed Central or State Public Sector Units/Autonomous Body/ Govt. agencies undertaking construction work of similar nature) for the work of **“Providing fabricating & supplying wooden furniture, special equipment and repairs to furniture for visual arts section in Kalakshetra Foundation, Thiruvanmiyur, Chennai- 41.”**

The sealed tenders along with proof of registered certificate, GST.No, PAN NO, REGN.NO should reach the Director, Kalakshetra Foundation, Thiruvanmiyur, Chennai- 41, on or before **19.05.2019 up to 5.00 p.m.** by post or by hand delivery and same will be opened on the next day **20.05.2019 at 3.00 p.m.** in the presence of the tenderer or his/ her representatives if they chose to attend. Late/delayed tenders received, due to any reason whatsoever will not be accepted under any circumstances.

In case bidders need any clarification/assistance may contact Engineer officer on any working day during the office hours and can be contacted at 044- 24524057/ 0836.

1.	Name of the work	<b>Providing fabricating &amp; supplying wooden furniture, special equipment and repairs to furniture for visual arts section in Kalakshetra Foundation, Thiruvanmiyur, Chennai- 41.</b>
2.	Notice Inviting Tender No	<b>F.No.A-76/01/2019/KF Dated-26.04.2019</b>
3.	Tender documents	The tender documents are to be downloaded either from the Foundation's website at <a href="http://www.kalakshetra.in">www.kalakshetra.in</a> or <a href="http://www.eprocure.gov.in">www.eprocure.gov.in</a> from <b>29.04.2019, 1.00 p.m.</b> onwards. If there is any difficulty in downloading the documents, same can be collected from the Foundation's Office free of cost on any working day between <b>10.00 a.m. to 5.00 p.m. till 19.05.2019 - 1.00 p.m.</b>
4.	Pre-bid meeting if required	<b>08.05.2019 at 3.00 p.m.</b> (the meeting will be held only if required otherwise clarification if any, sent to official email <a href="mailto:works@kalakshetra.in">works@kalakshetra.in</a> in advance, so that the same will be clarified)
5.	Last date and time for receipt of completed Tenders	<b>19.05.2019 up to 5.00 p.m.</b>
6.	Date and Time of Opening	<b>20.05.2019 at 3.00 p.m</b>
7.	Estimated cost put to bid	<b>Rs. 5,11,113.00</b>
8.	Amount of Earnest Money Deposit (EMD)	<b>Rs. 10,230/- (Rupees Ten thousand two hundred and thirty only)</b>
9.	Period of completion	<b>2 Months</b>

The Kalakshetra Foundation reserves the right to accept or reject, wholly or partly, any or all the applications without assigning any reason whatsoever. Kalakshetra Foundation decision in this regard will be final and binding on all applicants.

This issues with the approval of competent authority

Signature with Name and Seal of tenderer F.No. A-76 /01/2019/KF Dated- 26.04.2019

Page 2 of 29



## कलाक्षेत्र प्रतिष्ठान

KALAKSHETRA FOUNDATION

THIRUVANMIYUR, CHENNAI- 600 041 PH- 044- 24524057 / 0836

\*\*\*\*\*

### INSTRUCTIONS TO THE TENDER:

1. The intending bidder must read the terms and conditions carefully. He/she should only submit has bid if he/she considers himself eligible and he/she is in possession of all the documents required.
2. The intending bidder must have registered in the appropriate class in CPWD/State PWD / Railway /MES/BSNL/Reputed Central or State PSUs/Autonomous Body/ Govt. agencies undertaking similar works in nature. The sealed envelope must be super scribed **“Providing fabricating & supplying wooden furniture, special equipment and repairs to furniture for visual arts section in Kalakshetra Foundation, Thiruvanmiyur, Chennai- 41.”** with tender inquiry number and its due date.
3. The tender document should be filled in English and all entries should be typewritten or handwritten but there should not be any overwriting or cutting. Corrections, if any, shall be made by neatly crossing out, initialling, dating and rewriting.
4. The price/rate quoted should be indicated in words as well as in figures. If there is a discrepancy between words and figures, the lesser amount shall be considered as valid. If the tenderer does not accept the correction of the errors, the bid shall be rejected.
5. All pages provided in the tender document shall be numbered and submitted as a package along with forwarding letter on agency’s/firm’s letter head with signed and sealed before their submission.
6. Rates should be quoted as shown in format schedule and all applicable taxes and duties levied by government should be clearly mentioned by tenderer separately.
7. Tenders qualified by such vague and indefinite expressions such as “subject to prior confirmation”, “subject to immediate acceptance” etc. will be treated as vague offers and rejected accordingly.
8. The instructions given herein will be strictly binding on the tenderers and deviation, if any, not acceptable to the Kalakshetra Foundation, will make the tender or tenders liable to be considered invalid. Tender(s) incorporating additional conditions by the tenderer(s) are liable for rejection.
9. At any time, prior to the date of submission of bids, Kalakshetra Foundation for any reason, whether at its own initiative or in response to clarification(s) sought by prospective bidders, may issue clarifications by amending the bid documents. All such amendments shall be notified and intimated by e-mail to all the tenderers. All such amendments have to be considered as mandatory constituent part of the tender document.
10. The tenderers shall fill up the **(Part I)** in prescribed format and submit the same duly signed on all pages and sealed as a token of their acceptance. Incomplete tenders i.e. **“Part-I”** without all the supporting documents, EMD and duly filled in, copy of valid trade license, Copy of GST registration & PAN.NO certificate, Address proof of the firm signed and stamped with official seal in all the pages will be rejected straightway without any reference to the tenderers.



## कलाक्षेत्र प्रतिष्ठान

### KALAKSHETRA FOUNDATION

THIRUVANMIYUR, CHENNAI- 600 041 PH- 044- 24524057 / 0836

\*\*\*\*\*

11. The tenderers shall quote their rate in percentage above or below the cost mentioned in the schedule of quantities (**Financial Bid**) – **Part -II** and submit the same duly signed and sealed. Overwriting in the Financial Bid is not permitted and shall be rejected straightway without any further reference.
12. Conditional tenders shall not be accepted.
13. Tenders submitted via electronic transmission or through e-mail shall not be accepted.
14. In case the last date of receipt/opening of tender is declared as a holiday, the tenders shall be opened on the next full working day.
15. The authorities of Kalakshetra Foundation do not bind themselves to accept mere lowest tender and reserves the right to reject or accept any or all tenders wholly or partially without assigning any reason whatsoever.
16. The bids shall be valid for a period of **120 days** from the date of opening of the tender.
17. Canvassing whether directly or indirectly, in connection with tenders is strictly prohibited and the tenders submitted by the contractors who resort to canvassing will be liable to rejection.
18. Tender is not transferable. One tenderer shall submit only one tender.
19. Tenderer signing the tender must clearly, specify whether he/she is signing as Sole Proprietor, Authorized person, Partner, under Power of Attorney or as Director/ Manager/Secretary etc., as the case may be.
20. In case the tenderer fails to submit any of the required documents as per tender document or found unsuitable to execute the tendered job shall not be considered and shall be rejected straight away without any further reference.
21. The successful contractor shall not transfer wholly or partially the order of work to any other person(s) / firm / company for any reason whatsoever and in which case the order shall automatically stand cancelled.
22. Tender document submitted by the participants should be concise and contain only relevant information as required under this tender.
23. The participant would be responsible for all of its expenses, costs and risks incurred towards preparation of the tender document, attending any pre-bid meeting and visiting the site or any other location in connection therewith. Kalakshetra Foundation shall, in no case, be responsible or liable for any such costs whatsoever, regardless of the outcome of the tender process.
24. Specifications to be followed for execution of work for Civil Work: CPWD specifications 2009 Vol. I to II with up to date correction slips.



## कलाक्षेत्र प्रतिष्ठान

KALAKSHETRA FOUNDATION

THIRUVANMIYUR, CHENNAI- 600 041 PH- 044- 24524057 / 0836

\*\*\*\*\*

### GENERAL TERMS AND CONDITIONS

1. The successful tenderer shall commence the work within **4 (four)** working days from the date of award of work. The duplicate copy of the award letter duly signed with official stamp on all the pages to be submitted as a token of acceptance of the order.
2. The contractor shall also arrange for proper storage of the accessories at site and will be responsible for their watch and ward.
3. The site of work shall always be kept neat and clean and all building rubbish shall be periodically removed from the premises to avoid nuisance to occupants.
4. All precautions not to damage the Kalakshetra Foundation properties shall be taken by the contractor. If any damage is caused to any structure, building, trees etc. the same shall be made good by the contractor at his cost to the satisfaction of Kalakshetra Foundation authority concerned.
5. No payment will be made to the contractor for damage caused by rains during the execution of the works and no claim on this account will be entertained.
6. The work shall be carried out using metric dimensions only and shall be measured and paid in metric dimensions. F P S units, if any, mentioned in drawings etc. are for guidance only.
7. Wherever any reference to any Indian Standard Specification occurs in the documents relating to this contract the same shall be inclusive of all amendments issued there to or revision thereof if any, up to the date of receipt of tenders.
8. Unless otherwise specified in the schedule of quantities the rates for the various items are for all heights and locations.
9. Unless otherwise specified in the schedule of quantities the rate for the items of the work shall be considered, as inclusive of pumping out or bailing out water, if required, for which no extra payments will be made. This will include water encountered from any source, such as rains, floods, sub-soil water table being high or due to any other cause whatsoever.
10. The tenderer shall study the item description, the relevant drawings and satisfy him the item of work to be carried.
11. If a tenderer quotes nil rates / zero cost or Not quoted any item in item rate tender it will be presumed that the item of work will be done at zero cost by the bidder.
12. The contractor shall produce the copy of the current validity of the BIS certification of the agency from whom materials was procured by the contractor. BIS marked materials shall also be got tested. The materials and the quantity for which tests to be conducted shall be decided by the Kalakshetra Foundation authorities.
13. The contractor shall take instructions from the Kalakshetra Foundation authority for stacking of materials in any place. No excavated earth or building material shall be stacked on areas where other buildings, roads, services compound walls are to be constructed.
14. Some restrictions may be imposed by the security staff etc., on the working, staying in the labour



## कलाक्षेत्र प्रतिष्ठान

### KALAKSHETRA FOUNDATION

THIRUVANMIYUR, CHENNAI- 600 041 PH- 044- 24524057 / 0836

\*\*\*\*\*

shed in the campus and for movement of labour, materials etc. The contractor shall be bound to follow all such restrictions/instructions and nothing extra shall be payable on this account.

15. The contractor shall take all precautions to avoid all accidents by exhibiting necessary caution boards and by providing red flags, red lights and barriers. The contractor shall be responsible for any accident at the site of work and consequences thereof.

16. It shall be deemed that the contractor shall satisfied himself as to the nature and location of the work, transport facilities, availability of land for setting up of camp etc. The department will bear no responsibility for lack of such knowledge and the consequences thereof.

17. **Water Supply:** The Contractor has to make his own arrangements for water required for the work at work sites. If the water supply is arranged by the Kalakshetra Foundation, 1% of the value of the work done will be recovered from final bill.

18. **Electrical Power:** The Contractors will have to make their own arrangements for drawing electric power from the nearest power line after obtaining permission from the TNEB at his own cost. If the electrical power supply is arranged by the Kalakshetra Foundation, necessary Tariff rates shall have to be paid based on the actual consumption.

19. General Terms of payment: -

a) The rate quoted should be percentage.

b) Tender should be submitted in sealed cover along with the Earnest Money of **Rs. 10,230/- (Rupees Ten thousand two hundred and thirty only)**. The EMD is to be furnished in the form of Account Payee Demand Draft/ Fixed Deposit Receipt /Banker's cheque/BG from any of the schedule bank/ Nationalized Bank drawn in favour of KALAKSHETRA FOUNDATION payable at Chennai. In case of entities exempted from EMD, certificate may be furnished. EMD in any other form will not be accepted as valid EMD. EMD submitted by other bidders will be refunded within 15 days after the award of contract. No interest will be paid on the Earnest Money deposited with the Kalakshetra Foundation. Earnest Money deposit in respect of the successful tenderer will be retained with the Kalakshetra Foundation until entire work as per terms and conditions of the tender is completed. If the successful tenderer fails to execute the order strictly as per the terms and conditions of the tender, EMD shall be forfeited forth with after cancellation of the concerned order.

c) No advance/part payments shall be released. Gross work to be done together with net payment minimum Rs. 3.00 (Rupees three lakh only) for being eligible for interim payment, will be made to the successful contractor after certification from Engineer officer based on the measurement of works done and Final payment will be paid at the end of successful completion of work on submission of final bill of quantities (BOQ) along with detailed measurements certified by the engineer in charge. Payments will be made either by cheque or RTGS/NEFT within **15 (Fifteen)** working days only after the satisfactory completion of work.

d) 5% (Five percentage) Retention amount on the total value of work will be deducted at the time of passing the bills. The retention amount withheld by Kalakshetra Foundation will be returned at the end of defects liability period of **one year**. No interest will be paid for the retention amount.

e) Income Tax, whichever is applicable at the prevailing rates as applicable from time to time



## कलाक्षेत्र प्रतिष्ठान

### KALAKSHETRA FOUNDATION

THIRUVANMIYUR, CHENNAI- 600 041 PH- 044- 24524057 / 0836

\*\*\*\*\*

shall be deducted as per extant rules. Quoted rates shall be inclusive of applicable GST. Failing which it shall be presumed that the prices include all such charges and no claim for the same will be entertained.

f) Revision of rates will not be permitted for any reason during the extended period.

g) In the event of failure of work action will be taken to rescind the work and the work will be get through other agencies at contractor's risk and cost.

h) Deduction of any liability/damages incurred on behalf of the Service Provider/Contractor in the discharge of his/their obligations under this Tender.

i) During the progress of work, the Contractor/representative shall remain in touch with the Kalakshetra Foundation authorities and ascertain from them whether any excess over sanctioned cost is anticipated and/or has already occurred.

**20. Time of Completion:** - Time is the essence of the contract. If contractor fails to complete the work within stipulated period, Liquidated Damage (L.D.) @1% of actual contract amount per week shall be recovered from the bill of the successful tenderer subject to a maximum of 10% of the contract amount.

**21.** Deviation limits to be mentioned:

a) Deviation Limit for items of supply or related items: 100%

**22.** In case of Extra / Substituted Item the rate is to be worked out as follows.

In the case of Extra Item(s) being the schedule items (Delhi Schedule of Rates items), these shall be paid as per the schedule rate plus cost index (at the time of tender) plus/minus percentage above/ below quoted contract amount. Payment of Extra items in case of non-schedule items (Non-DSR items) shall be made as per the prevailing market rate at tender quoted rate.

**23.** In the case of substituted items (items that are taken up with partial substitution or in lieu of items of work in the contract), the rate for the agreement item (to be substituted) and substituted item shall also be determined in the manner as mentioned in the following para. (a) If the market rate for the substituted item so determined is more than the market rate of the agreement item (to be substituted), the rate payable to the contractor for the substituted item shall be the rate for the agreement item (to be substituted) so increased to the extent of the difference between the market rates of substituted item and the agreement item (to be substituted). (b) If the market rate for the substituted item so determined is less than the market rate of the agreement item (to be substituted), the rate payable to the contractor for the substituted item shall be the rate for the agreement item (to be substituted) so decreased to the extent of the difference between the market rates of substituted item and the agreement item (to be substituted).

**24.** For Deviated Quantities in the case of contract items, substituted items, contract cum substituted items, which exceed the prescribed limits laid down, determine the rates on the basis of the market rates and the contractor shall be paid in accordance with the rates so determined.

**25. TERMINATION OF AGREEMENT:** - The agreement/work order herein may be terminated at any time by either party by giving a written notice of **15days** to the other party.



**कलाक्षेत्र प्रतिष्ठान**

**KALAKSHETRA FOUNDATION**

THIRUVANMIYUR, CHENNAI- 600 041 PH- 044- 24524057 / 0836

\*\*\*\*\*

**ADDITIONAL CONDITIONS AND SPECIFICATIONS:**

The additional specifications given below are not substitute to CPWD specifications or IS specifications. These shall be read along with CP W D specifications or IS specifications.

1. The work shall be carried out using metric dimensions only and shall be measured and paid in metric dimensions. F P S units, if any, mentioned in drawings etc. are for guidance only.
2. Wherever any reference to any Indian Standard Specification occurs in the documents relating to this contract the same shall be inclusive of all amendments issued there to or revision thereof if any, up to the date of receipt of bids.
3. Unless otherwise specified in the schedule of quantities the rates for the various items are for all heights and locations.
4. Unless otherwise specified in the schedule of quantities the rate for the items of the work shall be considered, as inclusive of pumping out or bailing out water, if required, for which no extra payments will be made. This will include water encountered from any source, such as rains, floods, sub-soil water table being high or due to any other cause whatsoever.
5. The bidders shall study the item description, the relevant drawings and satisfy him the item of work to be carried out.
6. The rates quoted by the contractor shall be taken as net and nothing extra shall be paid on any account i.e. cartage, GST and stacking at required place etc.
7. The dismantling wherever required shall be done in a manner so that no other portions of the building or its fixtures are damaged. If any damage done to the building it shall be made good by the contractor at his own cost and no claim what so ever shall be entertained on this account.
8. The malba/garbage generated at site due to construction activities shall be removed from the Site to the location specified by Kalakshetra Foundation.
9. The contractor shall keep & clean the site thoroughly by removing scaffolding, surplus materials, rubbish, equipment left out of work and make clean clear the site around working site to the complete satisfaction of the Kalakshetra Foundation authorities before the work is treated as completed.
10. The Contractor shall not stack building material / malba / muck/ rubbish on the land or road of the Kalakshetra Foundation campus. The muck, rubbish etc. shall be removed periodically as directed by the Kalakshetra Foundation authorities from the site of work.
11. No materials shall be arranged / issued for the works by Kalakshetra Foundation.
12. All the tools, plants & safety of works arrangement will be borne by the contractor.





कलाक्षेत्र प्रतिष्ठान

KALAKSHETRA FOUNDATION

THIRUVANMIYUR, CHENNAI- 600 041 PH- 044- 24524057 / 0836

\*\*\*\*\*

13. The concrete mixture machine shall be used for lean concreting at the base.
14. The safety measure arrangement for the safety of men and materials shall be made by the contractor as per site requirement at his own cost and risk.
15. The work shall be carried out using metric dimensions only and shall be measured & paid in metric dimensions. F P S measurements, units if any mentioned in drawings is for guidance only.
16. The bidders shall study the item description, the relevant drawings and satisfy him the items of work to be carried out.
17. The rate quoted by bidder shall be taken as net rate and nothing extra shall be paid on any account i.e; cartage, GST and stacking at required place etc.,
18. All installation shall comply with the requirements of Indian Electricity rules, 1956 as amended upto date. In case items not covered by the above specifications the work should carried out as per the direction of Engineer in charge.
- 19 The copper wire to be used on the work shall be FRLS, multi-strand and ISI marked.
20. Approval of the Engineer shall be taken in advance for the materials to be used in the work by the contractor
21. The following makes are preferred for the following items:
  - a) PVC Pipes – Avonplast / AKG/ precision
  - b) FRLS PVC Copper Cable- Anchor / Finolex / Polycab / Standard
  - c) 450 mm wall mounted Fans – Almonard / Orient / Crompton
  - d) 1200 mm swipe ceiling fan – Almonard / Orient / Crompton
  - e) 24 watts LED Tube light fittings and accessories – Phillips / Havells / Crompton
  - f) EN 24 (European) 24 Steel grade for the rotating portrait stand assembly
  - g) Engineering drawing stand with laminated board – Techniker
  - h) Table top easel (compact type) – Techniker or equivalent make
  - i) Well-seasoned 1st quality Teakwood scantling and planks / Padauk wood 1<sup>st</sup> quality padauk wood scantling and planks shall be purchased for the work from reputed agencies.
  - j) Glass panels – M/s.Saint Gobin or equivalent

18. **Measurements:** Length and breadth of superficial area of the finished works shall be measure correct to a centimeter. Area shall be calculated in square meter correct to two decimal places. No deduction will be made to openings of area up to 40 square decimeters nor shall extra payment be made either for any extra materials or labour involved in making such openings. For openings exceeding 40 square decimeters in area, deduction in measurements shall be made but extra payment will be made for any extra materials or labour involved in making such openings.



कलाक्षेत्र प्रतिष्ठान

KALAKSHETRA FOUNDATION

THIRUVANMIYUR, CHENNAI- 600 041 PH- 044- 24524057 / 0836

\*\*\*\*\*

19. **Rate:** The rate shall include the cost of all materials + Labour involved in all operation described above including scaffolding etc., if any required in all respects.

**ARBITRATION CLAUSE:** - In the event of any dispute arising out of or in connection with this tender/contract/work order, whether during the subsistence of the contract or thereafter, the matter shall be referred to the Director, KALAKSHETRA FOUNDATION or any other officer nominated by the Director, KALAKSHETRA FOUNDATION for arbitration whose decision shall be final and binding on the parties. The proceedings before the Arbitrator would be governed by the provision of the Arbitration and Conciliation Act, 1996. The place of arbitration shall be Kalakshetra Foundation, Chennai.

The courts of Chennai will have exclusive jurisdiction for any issue/ dispute arising out of or in connection with the contract including relating to the arbitration proceedings.

\*\*\*\*\*



## कलाक्षेत्र प्रतिष्ठान

### KALAKSHETRA FOUNDATION

THIRUVANMIYUR, CHENNAI- 600 041 PH- 044- 24524057 / 0836

\*\*\*\*\*

#### (Part-I)

F.No.A-76 /01/2019/KF Dated-26.042019

To  
The Director  
Kalakshetra Foundation  
Thiruvanmiyur,  
Chennai – 600 041.

Date:

Dear Sir/Madam,

**SUB: Tender for – Providing fabricating & supplying wooden furniture, special equipment and repairs to furniture for visual arts section in Kalakshetra Foundation, Thiruvanmiyur, Chennai- 41..**

With reference to your tender enquiry cited above, we are pleased to enclose the Part-I for your kind consideration (as per prescribed format).

#### Our Company profile

i	Name of the agency/Contractor	:	
ii	Mailing address of the agency with PIN Code	:	
iii	Status of the Agency: Proprietor / Partnership / Regd. Company / Co-op. Society		
iv	Contact details		
	Telephone numbers(s)	:	
	Fax number(s)	:	
	E-mail address	:	
	Website	:	
v	GST registration No		
vi	PAN no.		
vii	Trade license no.		
viii	Bankers and their address along with type of Account & Account No		
ix	E.M.D details		
x	Registration certificate in current updated status from CPWD/State PWD/ Railways Dept/BSNL/Reputed Central or State PSU's/Autonomous body/Similar Govt. agencies – Certified copy to be enclosed		
xi	Certified copy of the works completion / experience certificate for completed works for the past 5 years, to be enclosed		

We confirm that we shall abide by all the tender conditions and we do not have any additional conditions.  
Thanking you,

Yours faithfully,

Signature with date and name of the signatory

Name of the Agency

(Seal of the agency)

Note: You may please attach a separate sheet as annexure for providing the details

Signature with Name and Seal of tenderer F.No. A-76 /01/2019/KF Dated- 26.04.2019

Page 11 of 29



## कलाक्षेत्र प्रतिष्ठान

### KALAKSHETRA FOUNDATION

THIRUVANMIYUR, CHENNAI- 600 041 PH- 044- 24524057 / 0836

\*\*\*\*\*

### FINANCIAL BID DOCUMENT - (Part-II) (Schedule of Quantities)

The Director  
Kalakshetra Foundation  
Thiruvanmiyur,  
Chennai - 600 041.

Dear Sir/Madam,

SUB: - **Tender for**- Name of work: Providing fabricating & supplying wooden furniture, special equipment and repairs to furniture for visual arts section in Kalakshetra Foundation, Thiruvanmiyur, Chennai- 41.

With reference to your tender enquiry cited we are pleased to enclose the following as our financial bid for your kind consideration (as per given format).

#### Schedule of quantities

Sl.No	DSR	Description of items	Quantity	Unit	Rate	Amount
1		Painting with synthetic enamel paint of approved brand and manufacture of required colour to give an even shade :				
	DSR 14.54.1	One or more coats on old work	50.00	sqm	51.30	2565.00
2		French spirit polishing				
	DSR 14.58	One or more coats on old work	100.00	sqm	105.85	10585.00
3	LMR	Providing, and fixing at site, clear float glass panes of thickness 12 mm, including the cost of chamfering glass panel edges smoothly in all respects	15.00	sqm	2781.00	41715.00



## कलाक्षेत्र प्रतिष्ठान

### KALAKSHETRA FOUNDATION

THIRUVANMIYUR, CHENNAI- 600 041 PH- 044- 24524057 / 0836

\*\*\*\*\*

4	LMR	Providing and supplying at site, engineering drawing stand with laminated drawing board with laminated top sheet finished - <b>A2</b> paper size 23" (inch) / 590 mm x 32"(inch) / 810 mm, with hollow steel section arrangement for the <b>Art / creative composition section</b> as per the drawing at <b>page 17 of 29</b> this document...	10.00	each	5060.00	50600.00
5	LMR	Providing and supplying at site, portable table top easel <b>compact type for Indian art section</b> - made out of good quality wood planks with standard furniture fittings and finishing with polishing etc., as required	10.00	cum	3500.00	35000.00
6	LMR	Providing fabricating and supplying at site, <b>long portrait easel stand - movable type</b> for Art / creative composition section, overall size 2.00 m height, 0.64 m length, 0.64 m width at base, using 1st quality seasoned teakwood scantling for frame work and base / bottom plank, standard furniture fittings, fixing PVC roller wheel - 4 Nos at base plank for movement purpose, Brass butt hinges-150 mmx 75 mm x 3 mm, C.P.Screws items including finishing with French spirit polishing etc as per drawing details at <b>page 18 to 25 of 29</b> of this document.	5.00	each	19125.00	95625.00



## कलाक्षेत्र प्रतिष्ठान

### KALAKSHETRA FOUNDATION

THIRUVANMIYUR, CHENNAI- 600 041 PH- 044- 24524057 / 0836

\*\*\*\*\*

7	LMR	Providing, fabricating and supplying at site working wooden table for <b>ceramic section</b> , 1.21 m length, 0.91 m width, 0.76 m height using 1st quality seasoned paduak wood scantling for frame work & top plank, teakwood lipping standard furniture fitting C.P.Brass items including finishing with enamel painting etc as per drawing at <b>page.26 of 29</b> this document.	1.00	each	17859.00	17859.00
8	LMR	Providing, fabricating and supplying at site working wooden table for <b>Graphic section</b> , 1.53 m length, 0.91 m width, 0.76 m height using 1st quality seasoned paduak wood scantling for frame work & top plank, teakwood lipping standard furniture fitting C.P.Brass items including finishing with enamel painting etc as per drawing at <b>page 27 of 29</b> this document.	1.00	each	35579.00	35579.00
9	LMR	Providing, fabricating and supplying at site working wooden table for <b>Art / creative composition section</b> , 1.83 m length, 1.06 m width, 0.76 m height using 1st quality seasoned paduak wood scantling for frame work & top plank, teakwood lipping standard furniture fitting C.P.Brass items including finishing with enamel painting etc. as per drawing at <b>page 28 of 29</b> this document.	1.00	each	39997.00	39997.00



## कलाक्षेत्र प्रतिष्ठान

### KALAKSHETRA FOUNDATION

THIRUVANMIYUR, CHENNAI- 600 041 PH- 044- 24524057 / 0836

\*\*\*\*\*

10	LMR	Providing, fabricating and supplying at site, <b>rotating portrait steel plate assembly (EN 24 steel grade)</b> - 370 mm dia, made out of 15 mm thick 2 Nos - using <b>EN 24 Grade steel</b> , pivot at center with cotter pin at pivot top , rotating 360 degree with 8 mm dia steel balls ( 110 Nos) , placed between top and bottom steel plates with proper / sufficient grooving track arrangement by machine work (Lathe or milling) for smooth rotation, and also providing self-tap threaded 10 mm diameter drill hole in the undercut area in the top and bottom plate - 6 nos The rate including fixing above assembly in the available wooden base and top with self-threaded 10 mm bolt - 70 mm length, nut and washer properly as per the direction of Engineer in charge, in all respects as per drawing at <b>page 29 of 29</b> this document.	9.00	each	10382.00	93438.00
11	LMR	Supplying installation testing and commissioning of 450 mm swipe plastic blade wall mounting type wall bracket fan including making connections etc. as required	15.00	each	2200.00	33000.00
12	LMR	Supplying installation testing and commissioning of 1200 mm swipe aluminium blade ceiling fan including making connections etc. as required	15.00	cum	2600.00	39000.00



## कलाक्षेत्र प्रतिष्ठान

### KALAKSHETRA FOUNDATION

THIRUVANMIYUR, CHENNAI- 600 041 PH- 044- 24524057 / 0836

\*\*\*\*\*

13	LMR	Supplying installation testing and commissioning of 24 watts Tube light LED fittings along with all accessories including connection, testing and commissioning etc., as required	17.00	each	950.00	16150.00
						511113.00
	Percentage above or below the estimated cost % in Figures & Words					
	Total cost Rs. in Figures & Words					

- The bidder/tenderer is need to quote the percentage only above or below or at par with the estimated cost to cover all the rates of item.
- The percentage shall be written in 2 (two) place of decimal
- The quoted rates are inclusive of GST prevailing at the time of calling tender.
- We confirm that on being successful in the tender we would take up and execute the work of Providing fabricating & supplying wooden furniture, special equipment and repairs to furniture for visual arts section in Kalakshetra Foundation, Thiruvanmiyur, Chennai- 41.
- We confirm that we will abide by all the tender conditions and we do not have any additional conditions.

Signature with date and name of the signatory

Name of the agency with seal





कलाक्षेत्र प्रतिष्ठान

KALAKSHETRA FOUNDATION

THIRUVANMIYUR, CHENNAI- 600 041 PH- 044- 24524057 / 0836

\*\*\*\*\*

ENGINEERING DRAWING BOARD A2 PAPER SIZE  
Laminated FINISHING

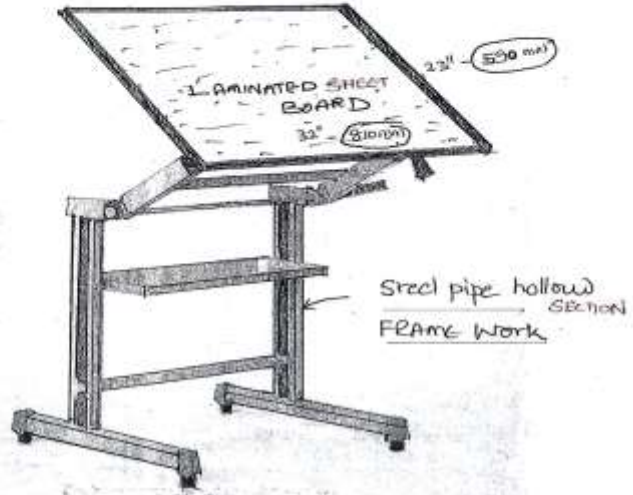



कलाक्षेत्र प्रतिष्ठान

KALAKSHETRA FOUNDATION

THIRUVANMIYUR, CHENNAI- 600 041 PH- 044- 24524057 / 0836

\*\*\*\*\*

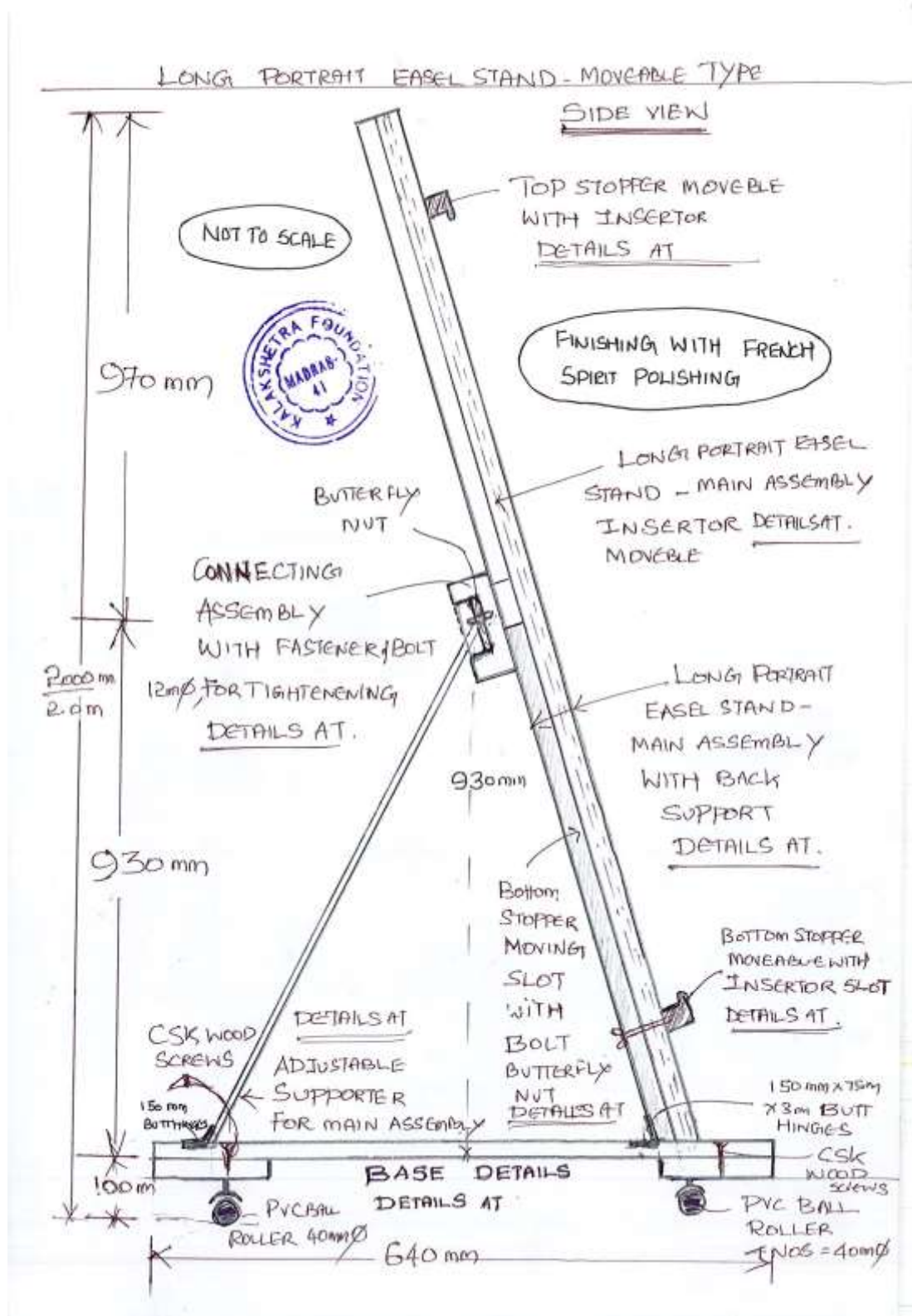



कलाक्षेत्र प्रतिष्ठान

KALAKSHETRA FOUNDATION

THIRUVANMIYUR, CHENNAI- 600 041 PH- 044- 24524057 / 0836

\*\*\*\*\*

NOT TO SCALE

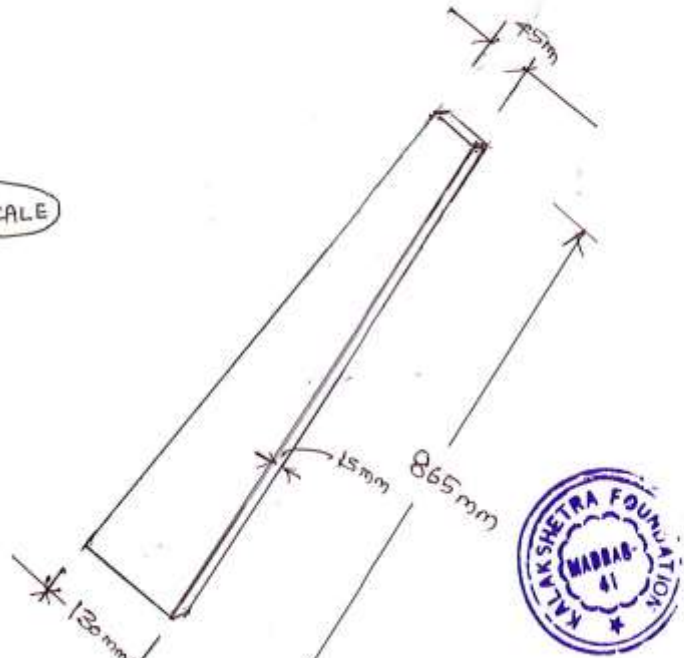

ADJUSTABLE SUPPORTER - USING 1<sup>st</sup> CLASS TEAKWOOD

FOR MAIN ASSEMBLY

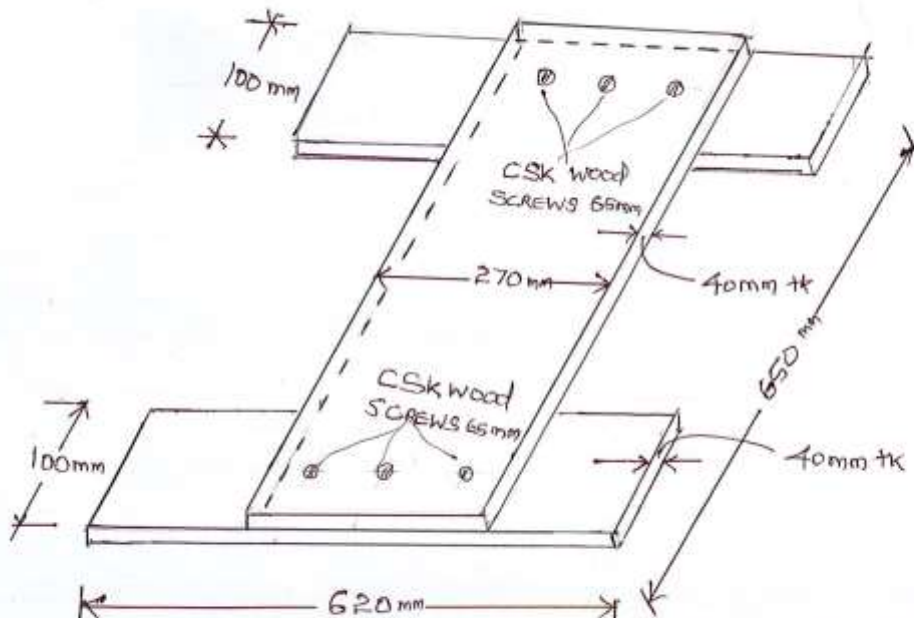

LONG PORTRAIT BASE DETAILS - USING 1<sup>st</sup> CLASS TEAKWOOD

4 NOS. 2" - PVC Ball roller to be fixed.



कलाक्षेत्र प्रतिष्ठान

KALAKSHETRA FOUNDATION

THIRUVANMIYUR, CHENNAI- 600 041 PH- 044- 24524057 / 0836

\*\*\*\*\*

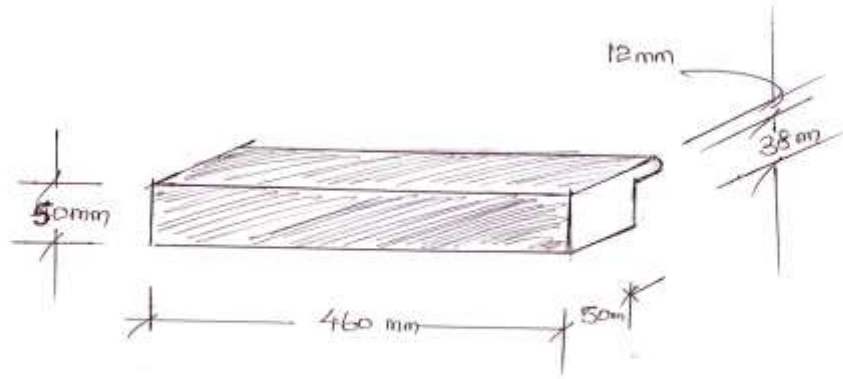

BOTTOM STOPPER MOVABLE WITH INSERTOR  
USING 1<sup>ST</sup> CLASS TEAKWOOD SLOT



NOT TO SCALE

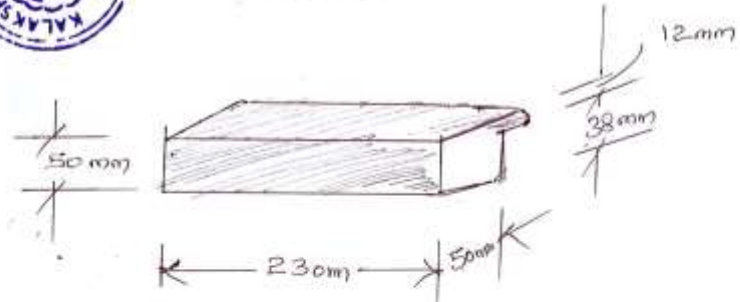

TOP STOPPER MOVABLE WITH INSERTOR  
USING 1<sup>ST</sup> CLASS TEAKWOOD



कलाक्षेत्र प्रतिष्ठान

KALAKSHETRA FOUNDATION

THIRUVANMIYUR, CHENNAI- 600 041 PH- 044- 24524057 / 0836

\*\*\*\*\*

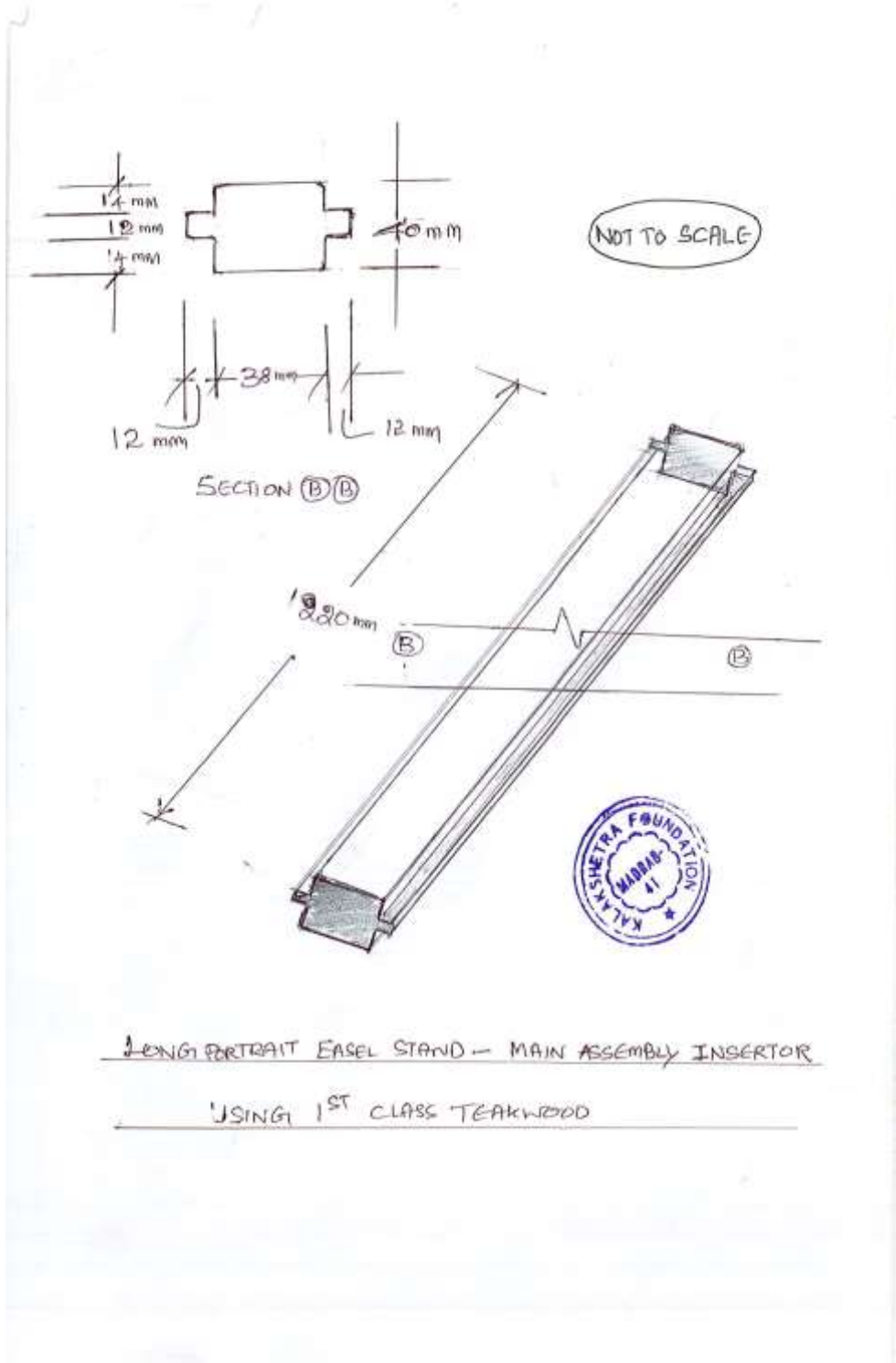

LONG PORTRAIT EASEL STAND - MAIN ASSEMBLY INSERTOR

USING 1<sup>ST</sup> CLASS TEAKWOOD



कलाक्षेत्र प्रतिष्ठान

KALAKSHETRA FOUNDATION

THIRUVANMIYUR, CHENNAI- 600 041 PH- 044- 24524057 / 0836

\*\*\*\*\*

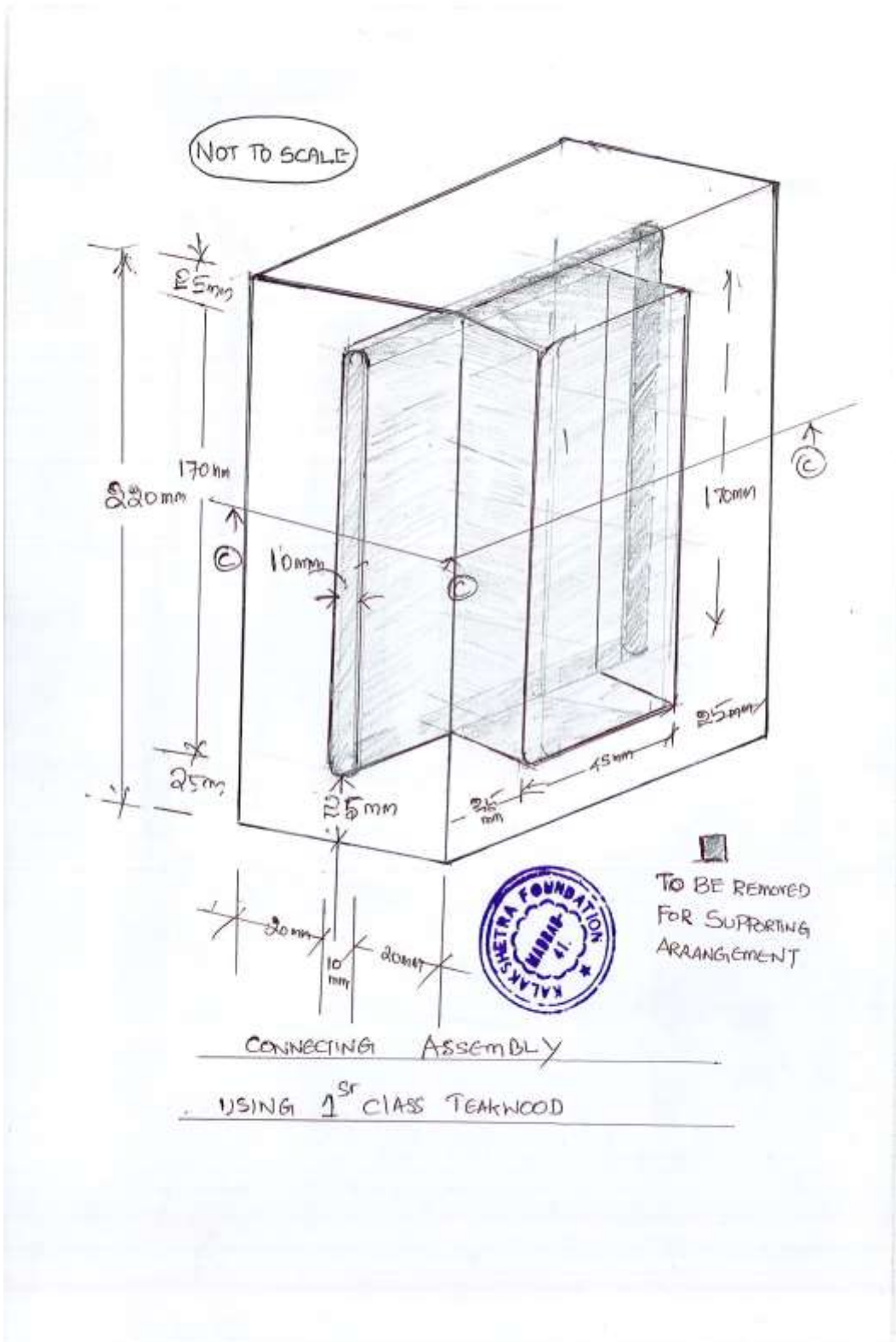



कलाक्षेत्र प्रतिष्ठान

KALAKSHETRA FOUNDATION

THIRUVANMIYUR, CHENNAI- 600 041 PH- 044- 24524057 / 0836

\*\*\*\*\*

NOT TO SCALE

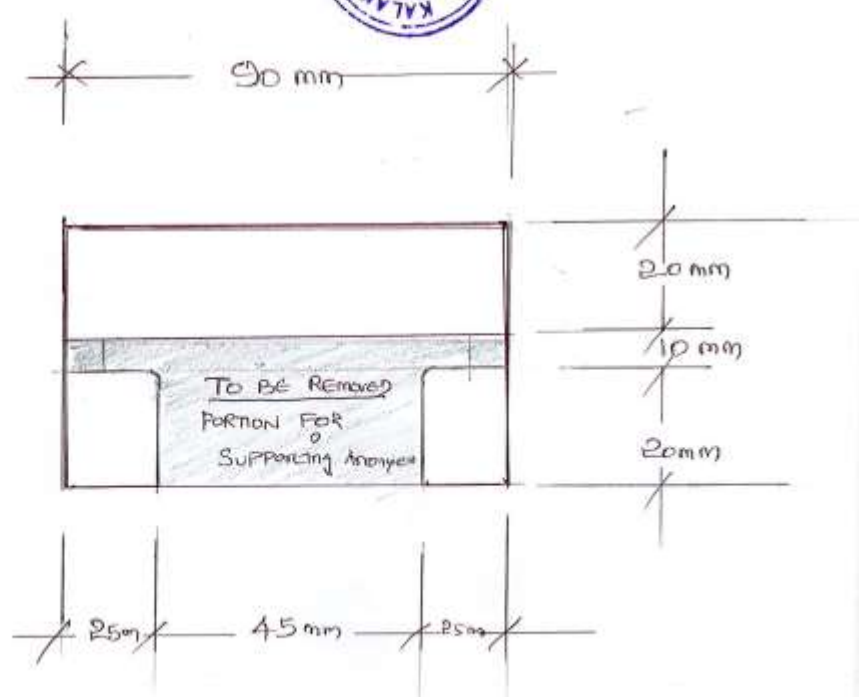

SECTION @ @ @

CONNECTING ASSEMBLY

USING 1<sup>st</sup> CLASS TEAKWOOD



कलाक्षेत्र प्रतिष्ठान

KALAKSHETRA FOUNDATION

THIRUVANMIYUR, CHENNAI- 600 041 PH- 044- 24524057 / 0836

\*\*\*\*\*

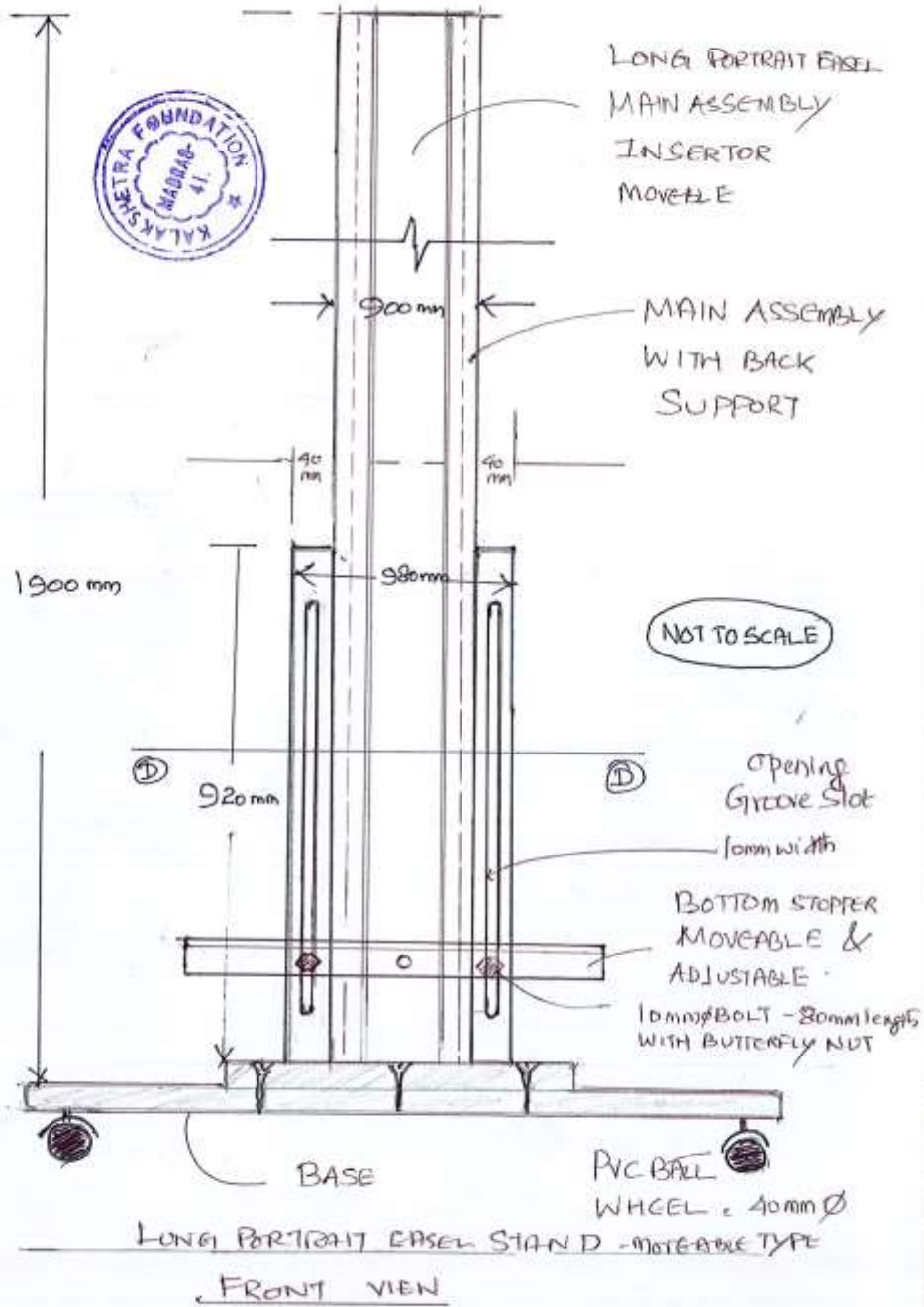





कलाक्षेत्र प्रतिष्ठान

KALAKSHETRA FOUNDATION

THIRUVANMIYUR, CHENNAI- 600 041 PH- 044- 24524057 / 0836

\*\*\*\*\*

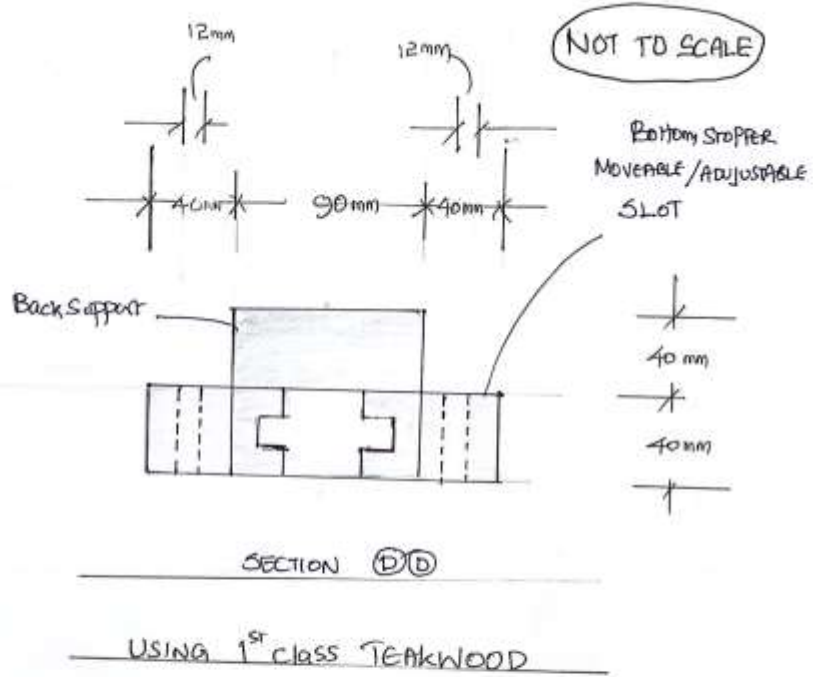



# कलाक्षेत्र प्रतिष्ठान

## KALAKSHETRA FOUNDATION

THIRUVANMIYUR, CHENNAI- 600 041 PH- 044- 24524057 / 0836

\*\*\*\*\*

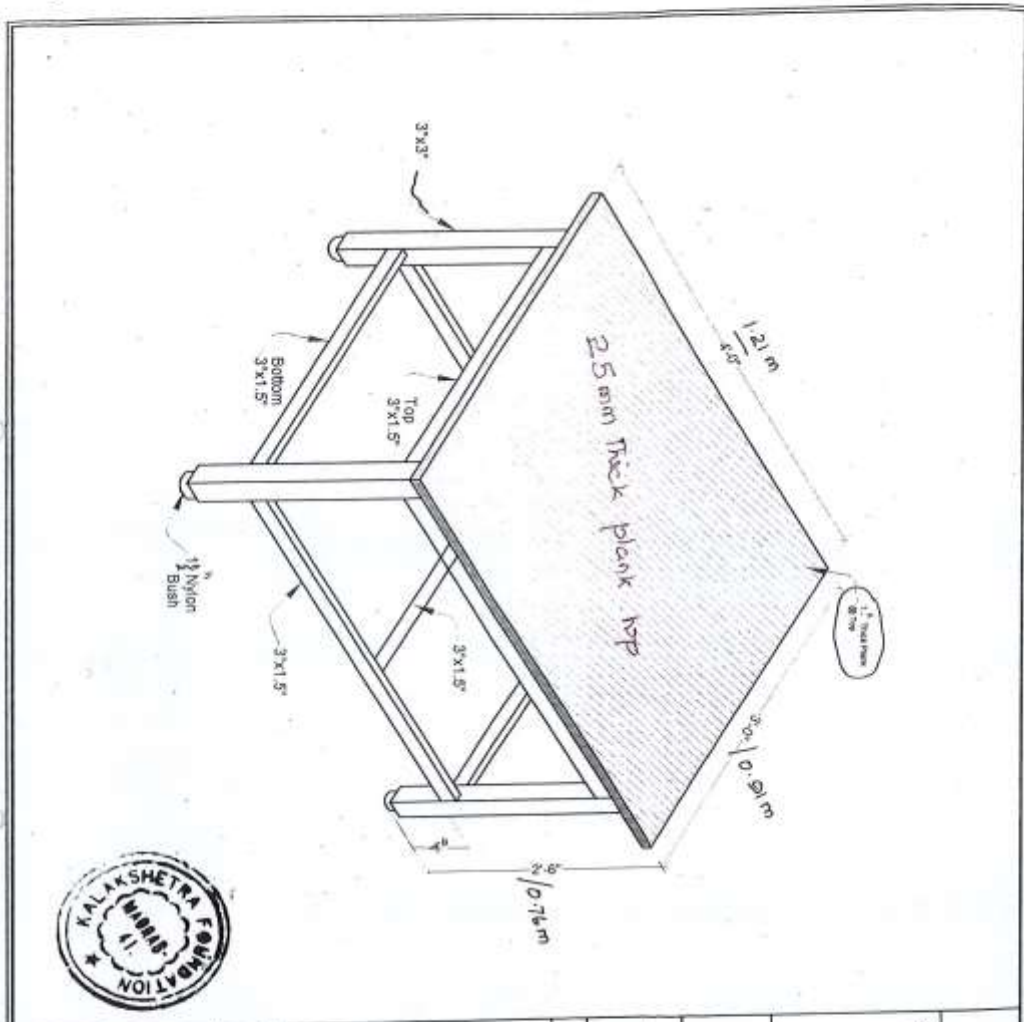

CERAMIC UNIT		
Size:-		
Length	Depth	Height
4'-0"	3'-0"	2'-6"
<b>WORKING WOODEN TABLE - ①</b>		
TOTAL QUANTITY: 1 No		
SPECIFICATIONS:-		
1. Using 1st Quality seasoned teak wood for frame work & top planks		
2. Teak wood fittings		
3. Enamel painting finishing		
4. Standard Furniture fittings - C.P. Bus Items		
DRAWING No : 1		
KALAKSHETRA FOUNDATION Thiruvanniyur, Chennai-41		



# कलाक्षेत्र प्रतिष्ठान

## KALAKSHETRA FOUNDATION

THIRUVANMIYUR, CHENNAI- 600 041 PH- 044- 24524057 / 0836

\*\*\*\*\*

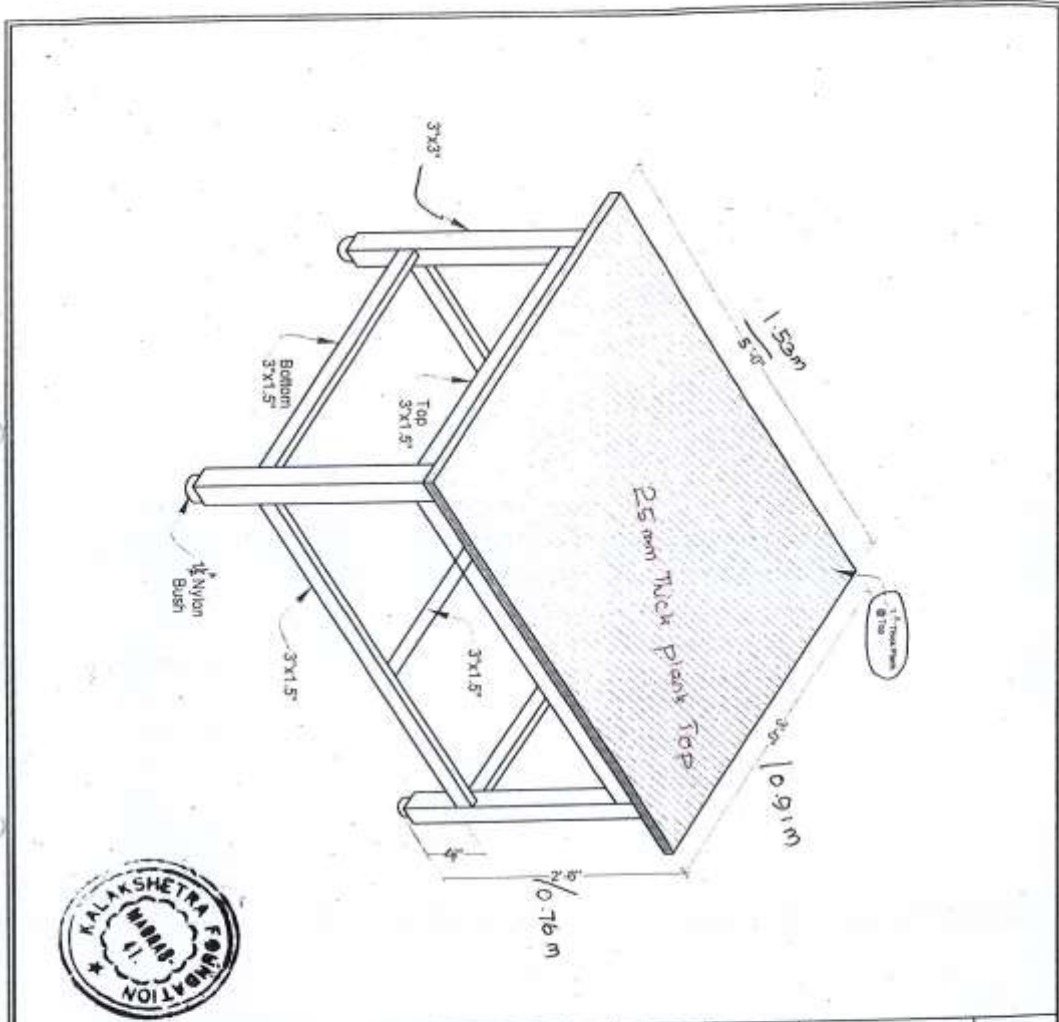

<b>GRAPHIC SECTION</b>		
Size:-		
Length 5'-0"	Depth 3'-0"	Height 2'-6"
<b>WORKING WOODEN TABLE</b>		
TOTAL QUANTITY: 1 No		
<b>SPECIFICATIONS:-</b>		
1. Using 1st Quality seasoned grade 'w' boarding for frame work & top planks		
2. Teak wood fittings		
3. Enamel painting finishing		
4. Standard Furniture fittings - C.P. Bush items		
DRAWING No : 2		
<b>KALAKSHETRA FOUNDATION</b> Thiruvaniyur, Chennai-41		



# कलाक्षेत्र प्रतिष्ठान

## KALAKSHETRA FOUNDATION

THIRUVANMIYUR, CHENNAI- 600 041 PH- 044- 24524057 / 0836

\*\*\*\*\*

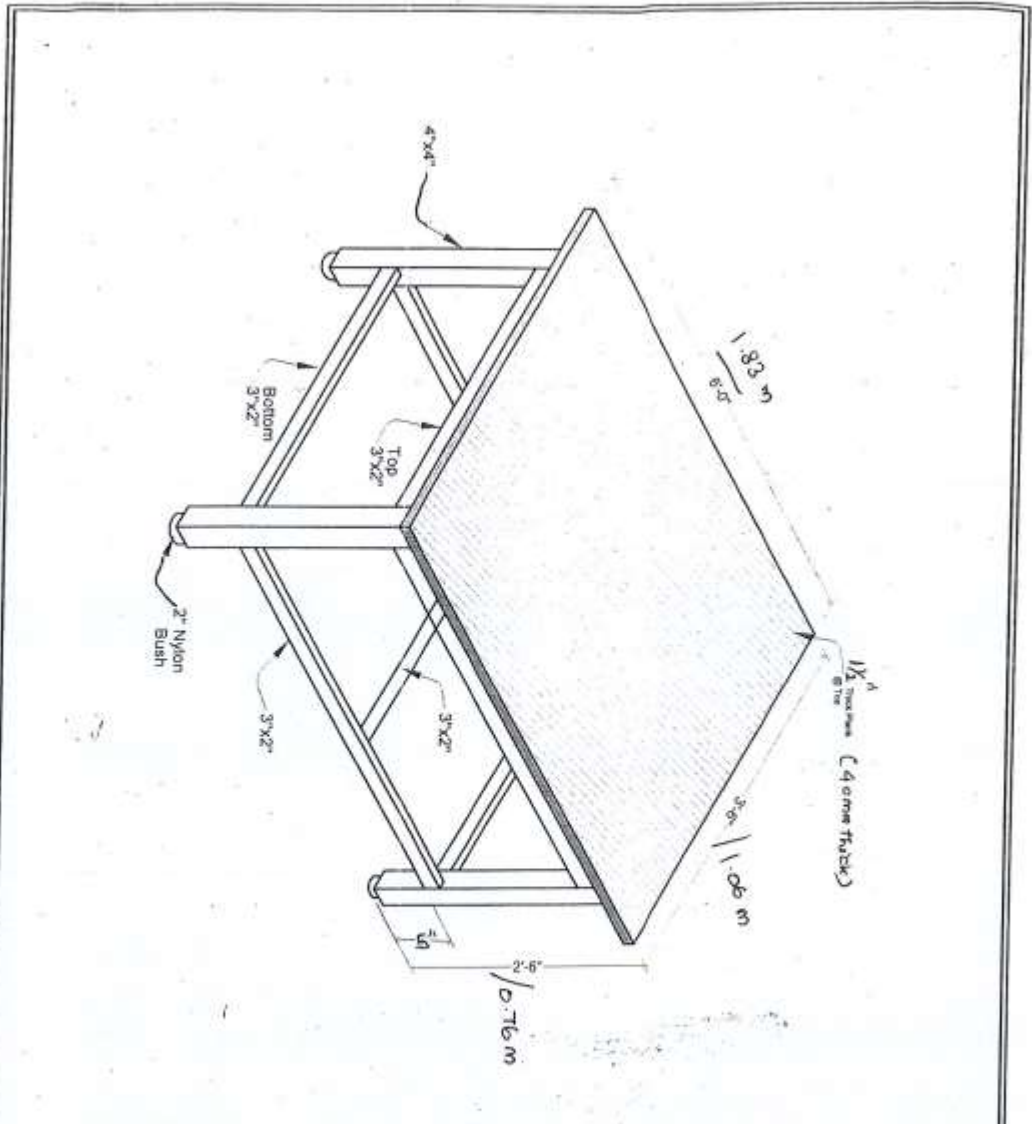

<b>ART / CREATIVE COMPOSITION SECTION</b>			
Size:-			
Length 8'-0"	Depth 3'-0"	Height 2'-0"	
<b>WORKING WOODEN TABLE - ③</b>			
TOTAL QUANTITY :- No			
SPECIFICATIONS :-			
1. Using 1st Quality seasoned parallel wood scanning for frame work & top boards			
2. Teak wood fittings			
3. Enamel painting finishing			
4. Standard Furniture fittings -C.P Brass items			
DRAWING No : 3, 19, 32			
<b>KALAKSHETRA FOUNDATION</b> Thiruvaniyur, Chennai-41			



कलाक्षेत्र प्रतिष्ठान

KALAKSHETRA FOUNDATION

THIRUVANMIYUR, CHENNAI- 600 041 PH- 044- 24524057 / 0836

\*\*\*\*\*

